

Stefano Pelinga - Shot 1

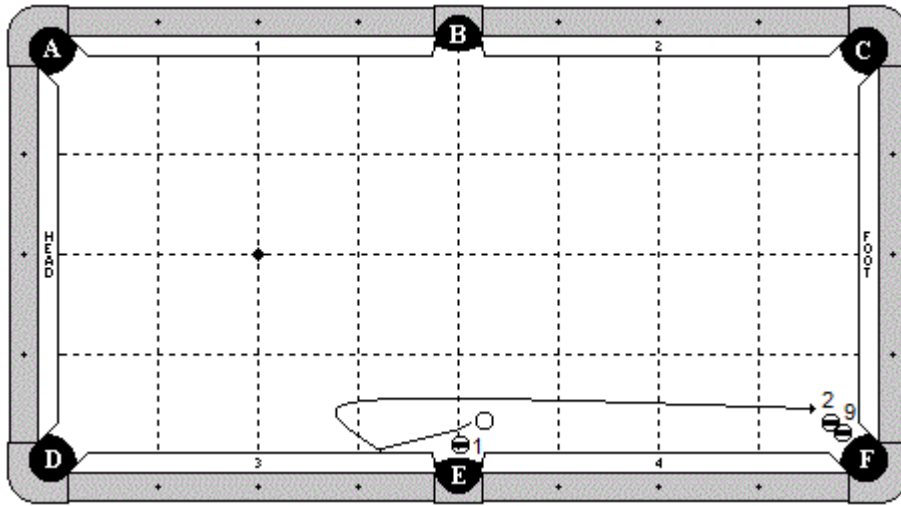

Category

Masse

Difficulty: 10

Cue Ball

In hand at $\frac{1}{2}$ ball distance from 1-ball.

Object Ball

1-ball centered in front of pocket E. Balls 2 and 9 by pocket F.

Props

None

Objective

Masse the CB to pocket 1-ball into E and hit the long rail past the side pocket. The CB then spins back to make 9-ball into F.

Special Notes

None

Stefano Pelinga - Shot 2

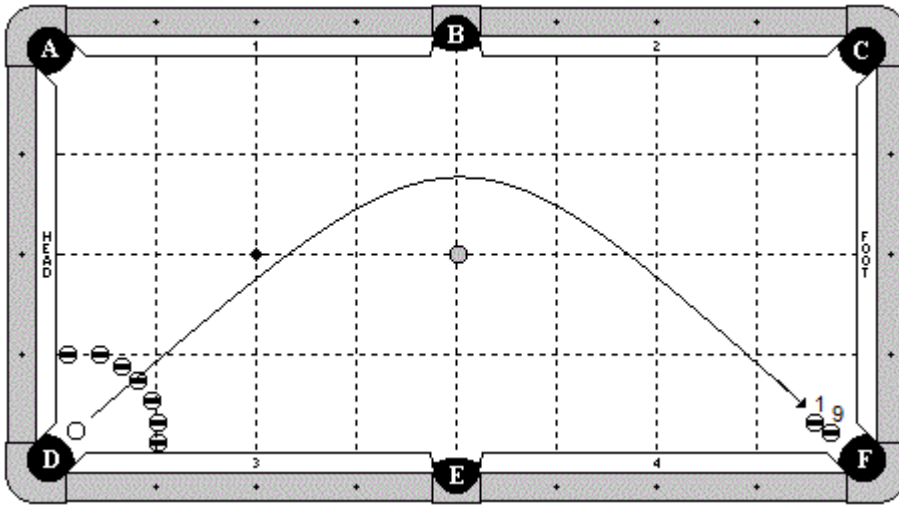

Category

Jump / Masse

Difficulty: 10

Cue Ball

Centered in front of pocket D.

Object Ball

1 and 9 ball by pocket F. A semi-circle of 7 balls spread from 1st diamond to the other 1st diamond.

Props

A can or bottle in the center of the table.

Objective

Jump the CB out of the circle of balls, masse around the bottle to pocket 9-ball into F.

Special Notes

None

Stefano Pelinga - Shot 3

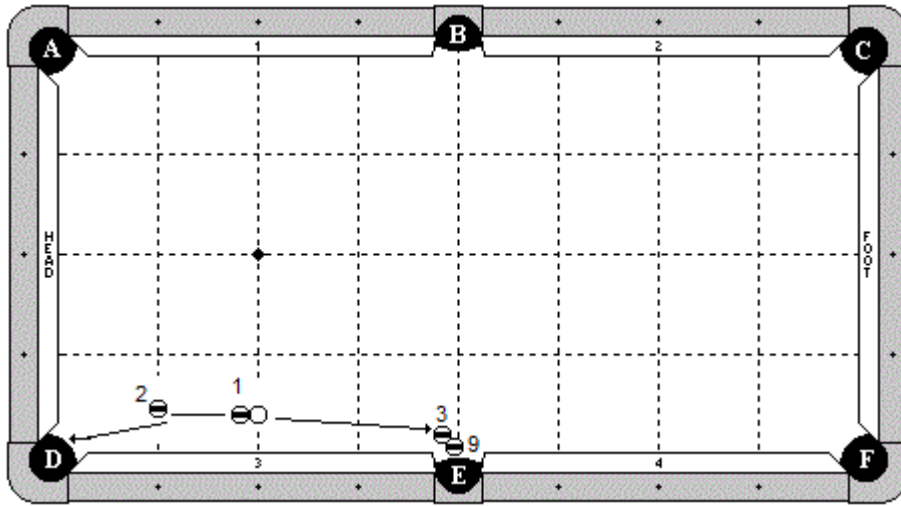

Category

Miscellaneous

Difficulty: 10

Cue Ball

In hand in line with 2nd diamond.

Object Ball

1-ball frozen to CB, in hand. 2-ball in hand and in line with 1st diamond overlapping clearly the 1-CB line of centers. 3 and 9 ball by pocket E.

Props

None

Objective

Shoot the 1-ball against the 2-ball. The CB will double hit the 1-ball making it into pocket D and draw back to pocket 9-ball in E pocket. CB can hit the long rail on its way towards the 3-ball.

Special Notes

None

Stefano Pelinga - Shot 4

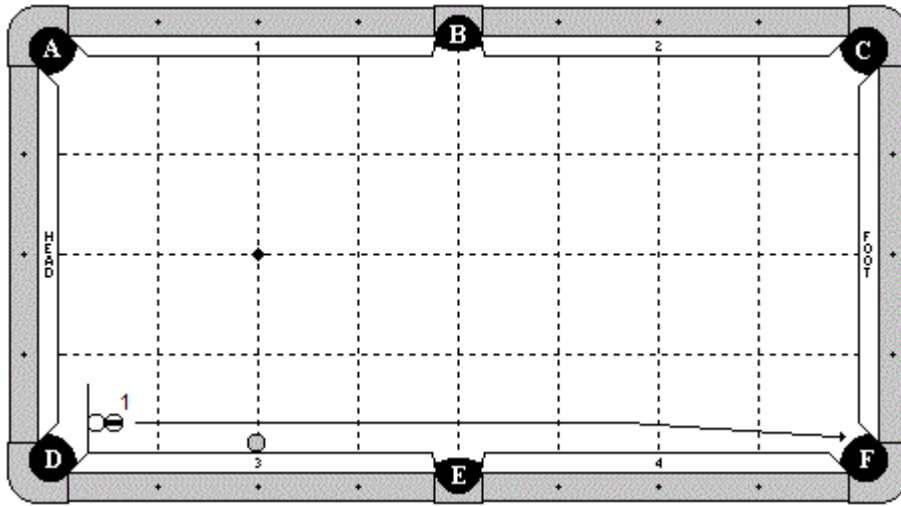

Category

Miscellaneous

Difficulty: 10

Cue Ball

With the back edge even with line X, at 1 ball width from long rail.

Object Ball

1-ball frozen to CB at 1 ball distance from long rail.

Props

A can or similar object with diameter not smaller than a ball frozen to long rail at 2nd diamond.

Objective

Shoot the 1-ball down the table without touching the obstacle. Re-hit with the cue ball the 1-ball and make it into pocket F.

Special Notes

None

Stefano Pelinga - Shot 5

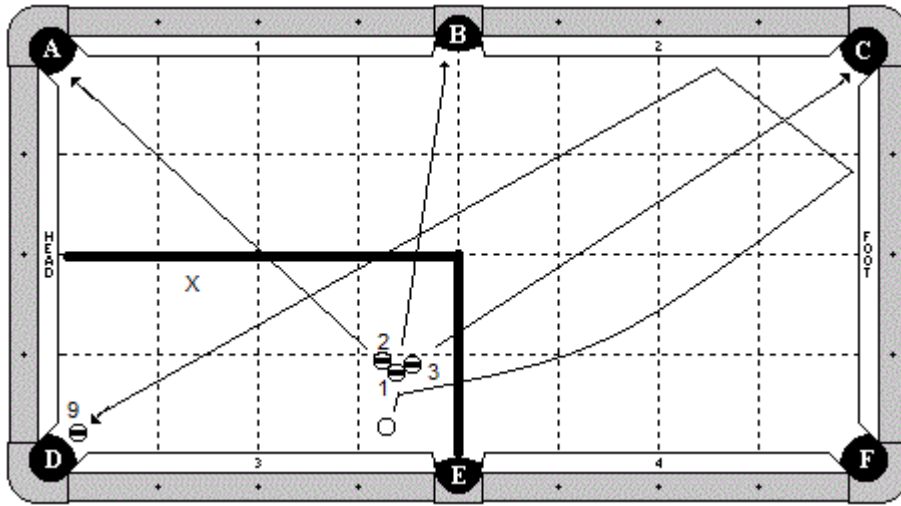

Category

Miscellaneous

Difficulty: 10

Cue Ball

In hand but close to what is shown in the diagram.

Object Ball

1, 2 and 3 ball frozen to each other and in hand within zone X. 9-ball centered at pocket D.

Props

None

Objective

Force follow the CB to hit the 1-ball and pocket respectively the 1-ball in pocket B, 2-ball in A and 3-ball in C. The CB hits 2 or more rails to pocket 9-ball in D.

Special Notes

None

Stefano Pelingia - Shot 6

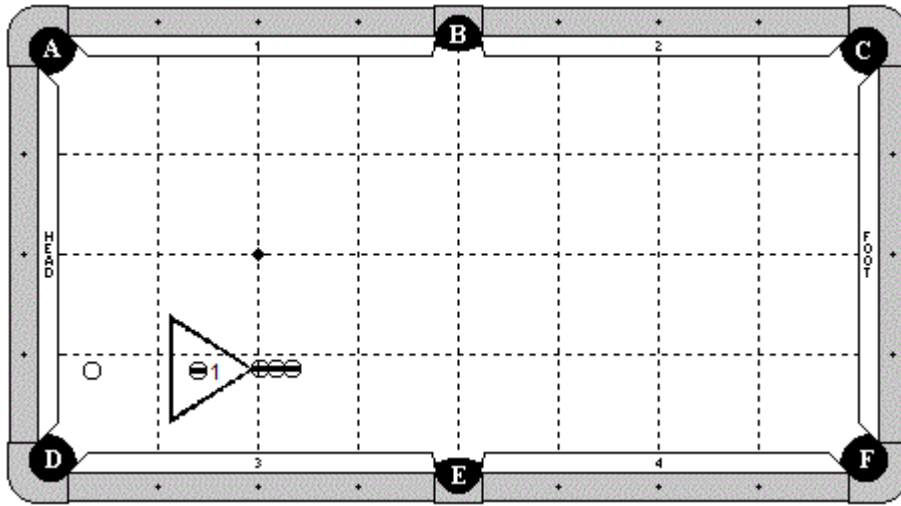

Category

Jump

Difficulty: 10

Cue Ball

In hand.

Object Ball

1-ball in hand inside the rack. 3 balls in straight line from apex of rack, as shown.

Props

A rack in hand behind the 2nd diamond.

Objective

Jump CB onto 1-ball, having it jump out of the rack, fly over the 3 obstacle balls and pocketing it in pocket F. The 3 obstacle balls cannot be touched and the CB has to remain on the table.

Special Notes

None

Stefano Pelinga - Shot 7

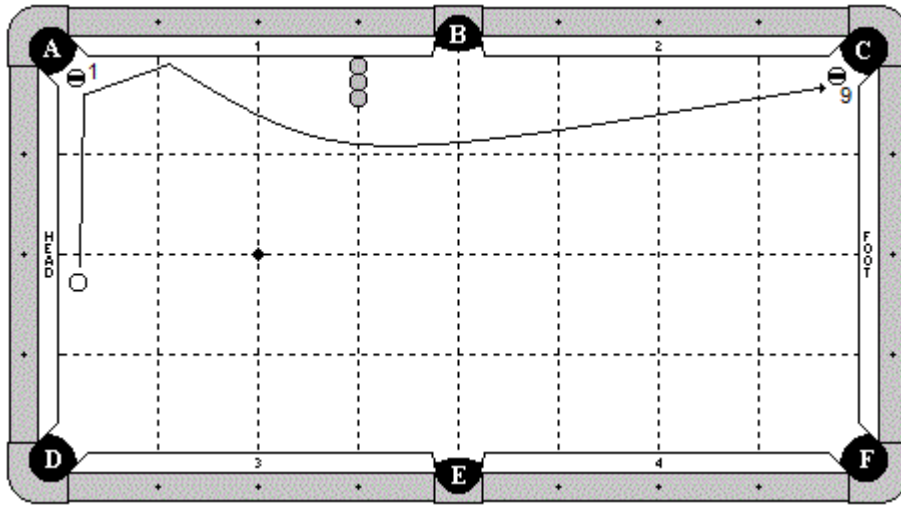

Category

Stroke

Difficulty: 10

Cue Ball

Behind 2nd diamond line, in hand.

Object Ball

1-ball centered in front of pocket A. 9-ball centered at pocket C.

Props

3 plastic 1 pint bottles lined at 1st diamond from pocket B, frozen to the rail and to each other. The obstacle has to be placed at a distance from the rail equal to 3 balls lined up, with the outer edge of the chosen obstacle being even with the supposed outer edge of the third ball.

Objective

Pocket the 1-ball with a force follow stroke. Hit the long rail once, curve around the bottles without touching them and pocket the 9-ball in pocket C. An extra rail can be touched before making the 9-ball.

Special Notes

None