

Trick Shot Magic

**Master Shot Book
2010**

Produced by Billiards International

Shot 1

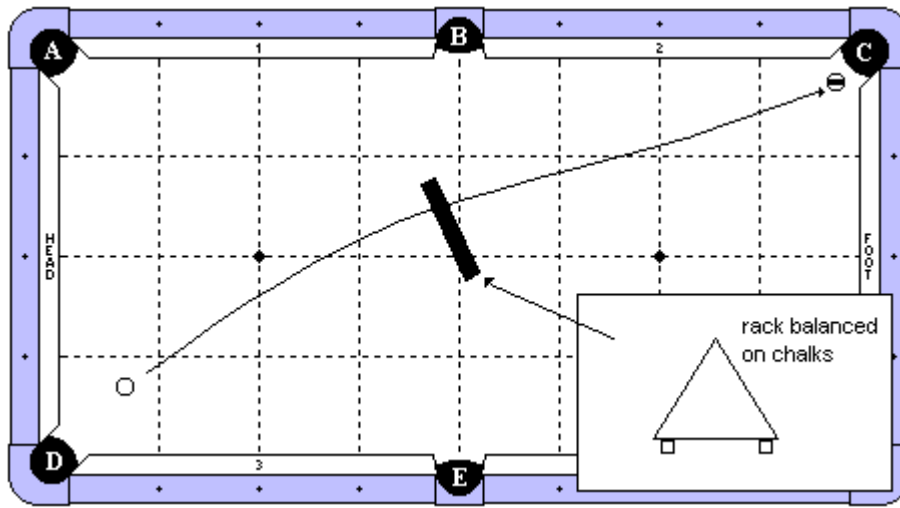

Category

1-handed jump

Difficulty: 10

Cue Ball

In hand within 1x1 diamond square near pocket D.

Object Ball

An object ball is hanging near pocket C.

Props

A rack is standing upright, balanced on 2 chinks (1 on each side). The rack is adjustable, but must cover the center point of the table.

Objective

With one hand, jump the cue ball through the rack, making the object ball in pocket 'C'.

Special Notes

The rack may be hit but it may not fall off the chinks. The cue ball may not fly off the table. After the object ball is made, if the cue ball comes around and hits the rack and it falls off the chinks at that point, the shot is good.

Shot 2

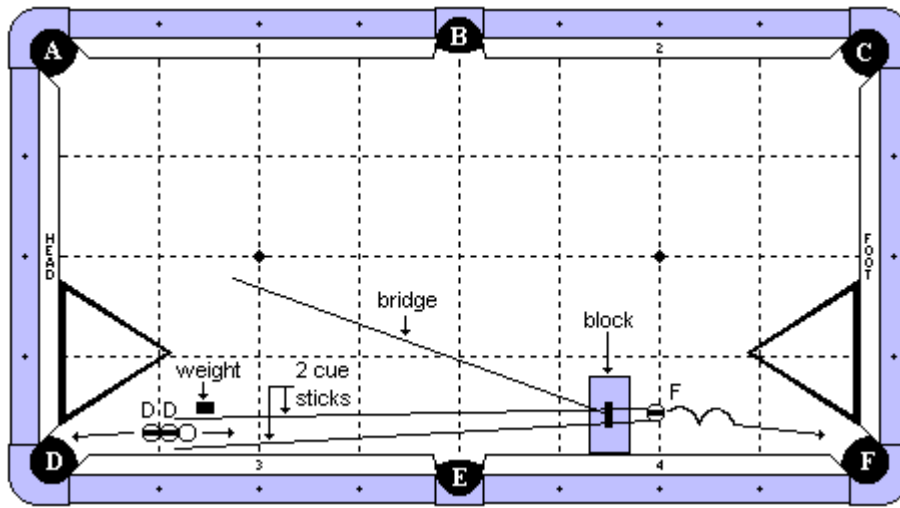

Category

Masse

Difficulty: 9

Cue Ball

In hand, between the two sticks.

Object Ball

Two 'D' object balls are in line with the cue ball. The balls are all frozen in line as diagrammed. The balls may be adjusted. 'F' ball is balanced on top of the two sticks, held in place by a rubber band wrapped around the sticks.

Props

Two racks are frozen to the head and foot cushion as diagrammed. An object measuring between 6 and 10 inches tall is placed approximately as diagrammed (adjustable). A bridge is placed on top of the object and angled down towards the table. Two cue sticks are placed on top of the bridge, forming a ramp. A weight is placed against the outer cue stick to hold it in place. Players may use anything for this weight as long as it does not interfere with the shot.

Objective

Masse the cue ball, making both 'D' balls into pocket 'D'. The cue ball will travel up the ramp, making the 'F' ball fall off and go into pocket F. The cue ball will then come back down the ramp, and scratch in pocket D.

Special Notes

Both 'D' balls must go in on their own. They may not be made by the cue ball coming back down the ramp.

Shot 3

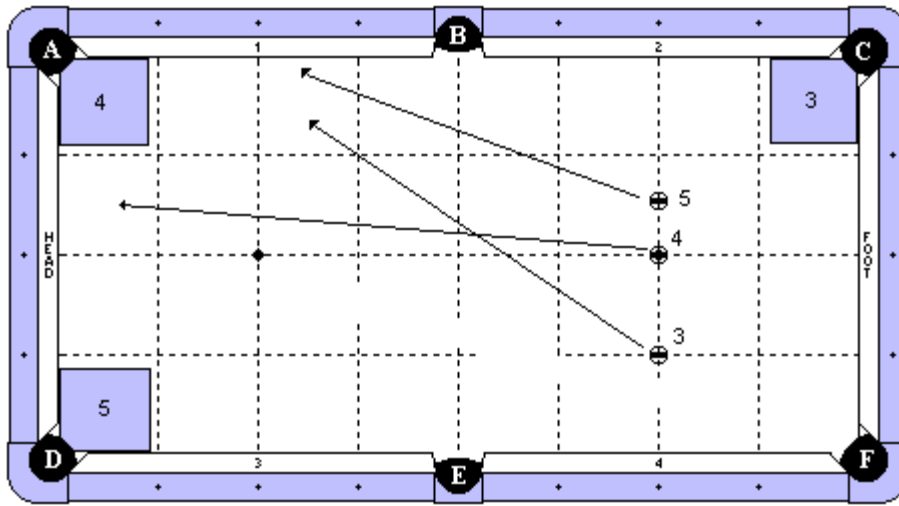

Category

Miscellaneous

Difficulty: 8

Cue Ball

None

Object Ball

3 object balls are in hand along the 2nd diamond line. The balls must be in the diagrammed order along the line, but may be shifted without switching their position.

Props

3 cloths, measuring between 16 and 18 inches are placed near the corner pockets as diagrammed. The cloths are placed so the edges are even with the cushion nose.

Objective

Shoot the balls in reverse numerical order (5,4,3). The 5 ball will travel 5 cushions and land on the cloth marked '5'. The 4 ball will travel 4 cushions and land on the cloth marked '4'. The 3 ball will travel 3 cushions and land on the cloth marked '3'. The 3 ball must be hit before the 5 ball touches its respective cloth.

Special Notes

It is okay if the object balls catch an extra rail or two near their final destination. For example, the 3 ball will travel 3 cushions, and it is okay it hits cushion 2 and/or the foot cushion at the end of its path.

Shot 4

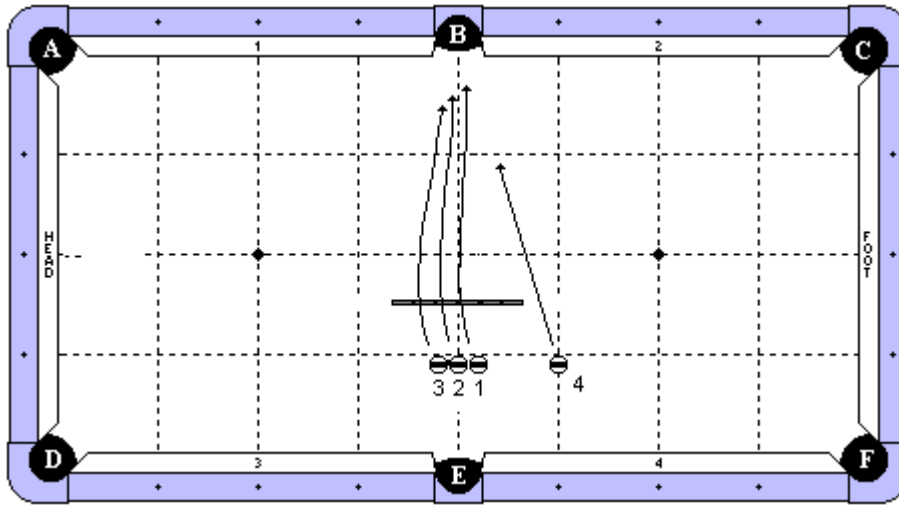

Category

Speed / Jump

Difficulty: 9

Cue Ball

None

Object Ball

Object balls 1, 2, and 3 are behind the 1st diamond line, with their forward edge even with that line. The 2 ball is centered between the pocket points, and the 1 and 3 balls may not be more than 1 inch away from the 2 ball. The 4 ball is on the 3rd diamond line, and has its forward edge even with the 1st diamond line.

Props

A row of 6 dominos are across the table on the 1 1/2 diamond line. The dominos are in their short position so the height is about 1.25 inches. The row of dominos may be shifted slightly if they get in the way of the 4 ball.

Objective

Shoot the 4 ball towards the side pocket. Then jump the balls in numerical order (1,2,3) over the dominos into the side pocket. The balls must go into the side pocket in numerical order.

Special Notes

The dominos may not fall over by any means.

Shot 6

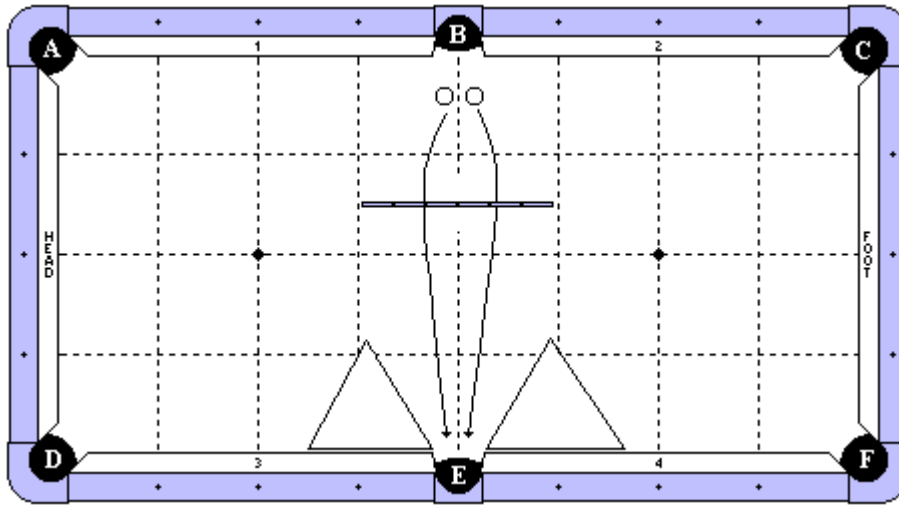

Category

1-handed jump

Difficulty: 9

Cue Ball

Two cue balls are used. Both are placed $\frac{1}{2}$ diamond away from pocket B. They are centered around the center line between the side pockets and they may be no more than 1 inch apart.

Object Ball

None

Props

A row of 6 dominos are in line at the $1\frac{1}{2}$ diamond line. The dominos are frozen and they are in their short position, measuring 1.25 inches high. Two racks are placed frozen to cushions 3 and 4 as diagrammed. The racks may be adjusted along the cushion.

Objective

Holding 2 cue sticks, jump both cue balls simultaneously over the dominos, and into pocket E. Both jump shots will be one-handed. One cue ball will be jumped 1-handed lefty and the other cue ball will be jumped 1-handed righty.

Special Notes

The cue balls may contact the racks, but the dominos may not fall over by any means. The player must use one forward motion stroke and jump both cue balls at approximately the same time. There may not be a pause, jumping one cue ball after the other.

Shot 7

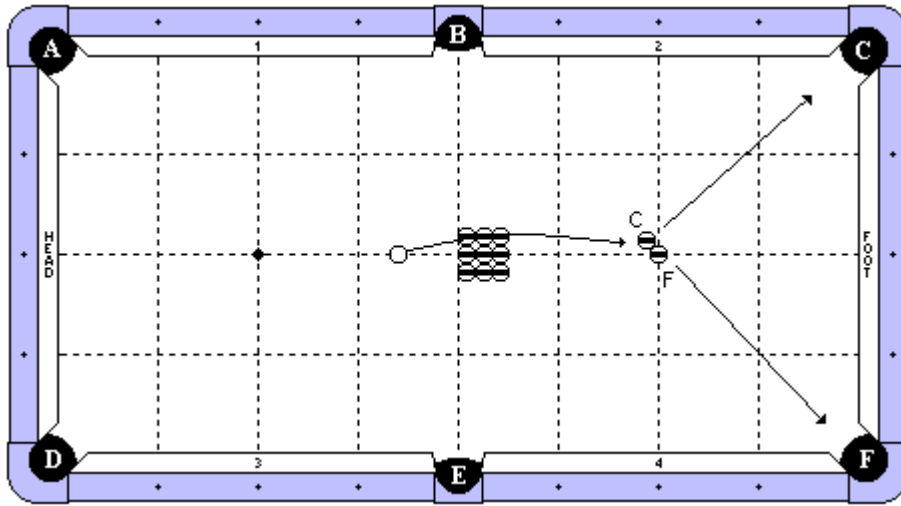

Category

Jump

Difficulty: 6

Cue Ball

On the center line of the table, exactly 3 ball's width from the center ball of the back line.

Object Ball

'F' ball is on the foot spot. 'C' ball is in hand, frozen to 'F' ball. A 3x3 square of 9 balls is positioned as diagrammed. The edge of the back line of 3 balls (the balls closest to the cue ball) have their edge at the center line of the table. The center 3 balls are along the long center line of the table.

Props

None

Objective

Jump the cue ball over the 9 blocking balls, hit 'C' ball, and make 'C' ball into pocket C and 'F' ball into pocket F.

Special Notes

The 9 blocking balls may not be touched until after both balls have been made. The player must shoot this 2-handed.

Shot 8

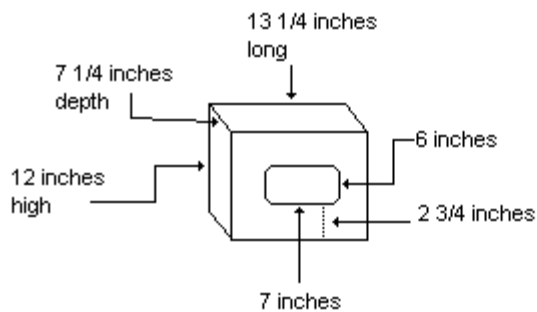
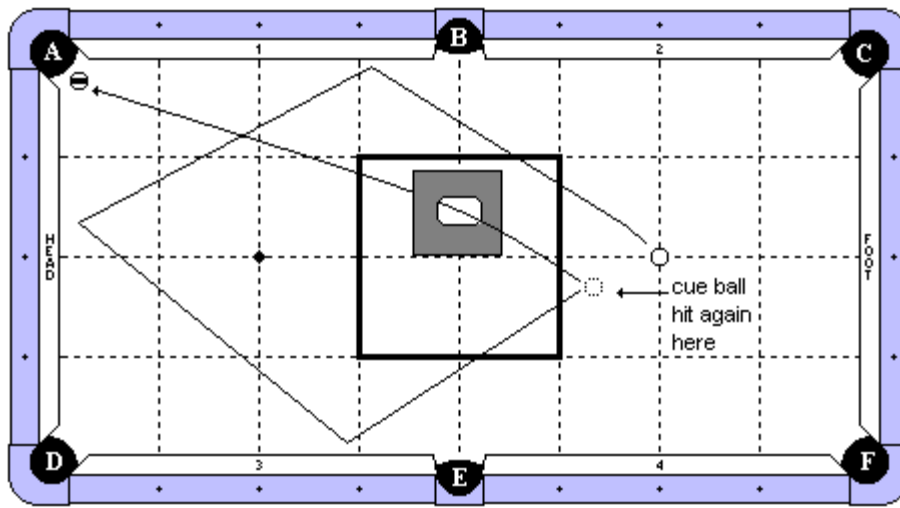

Category

Jump / Juggling

Difficulty: 8

Cue Ball

On the foot spot

Object Ball

An object ball is hanging by pocket A.

Props

A box is in hand within the indicated zone. The dimensions of the box are given in the diagram. Players are free to use their own box, provided the dimensions are within $\pm 1/4$ inch of the given dimensions.

Objective

Hit the cue ball 3 rails as indicated by the diagram. When the cue ball comes around, hit it again and jump it through the hole in the box, making the object ball in pocket A.

Special Notes

The box may not be hit by any means until after the object ball is made. The cue ball must be moving when jumping it through the box.

Shot 9

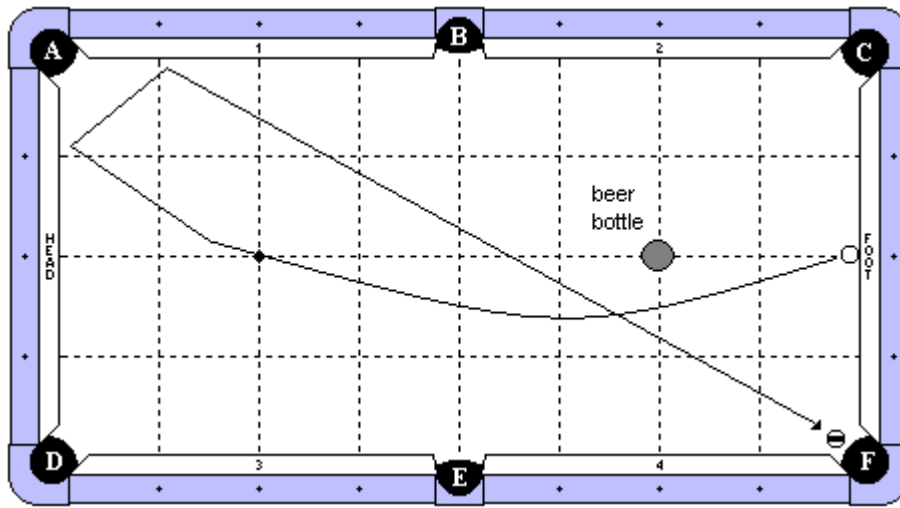

Category

Masse

Difficulty: 8

Cue Ball

Frozen to the cushion on the middle diamond.

Object Ball

An object ball is hanging near pocket F.

Props

A bottle is on the foot spot.

Objective

The cue ball will masse around the bottle and go 2 or more rails as diagrammed, and make the object ball in pocket F.

Special Notes

The cue ball may not touch the bottle.

Shot 10

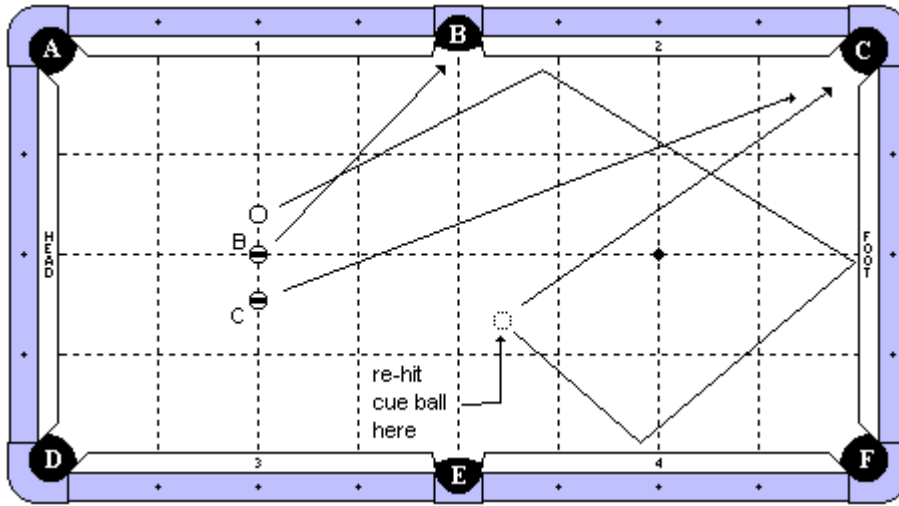

Category

Juggling

Difficulty: 7

Cue Ball

On the head string, in hand.

Object Ball

'B' ball on the head spot. 'C' ball in hand on the head string, to the right of 'B' ball (opposite side as the cue ball).

Props

None

Objective

Hit the cue ball first. It will travel three rails approximately to the marked point. While the cue ball is rolling, shoot 'B' ball next into pocket 'B'. Then shoot 'C' ball towards pocket 'C'. Reposition yourself and hit the moving cue ball again into pocket 'C'. The cue ball must go into pocket 'C' before 'C' ball goes in.

Special Notes

This entire shot must be performed free-handed. The hands may not touch the table at any point during the shot. The cue ball must be moving when hit a second time.

Shot 11

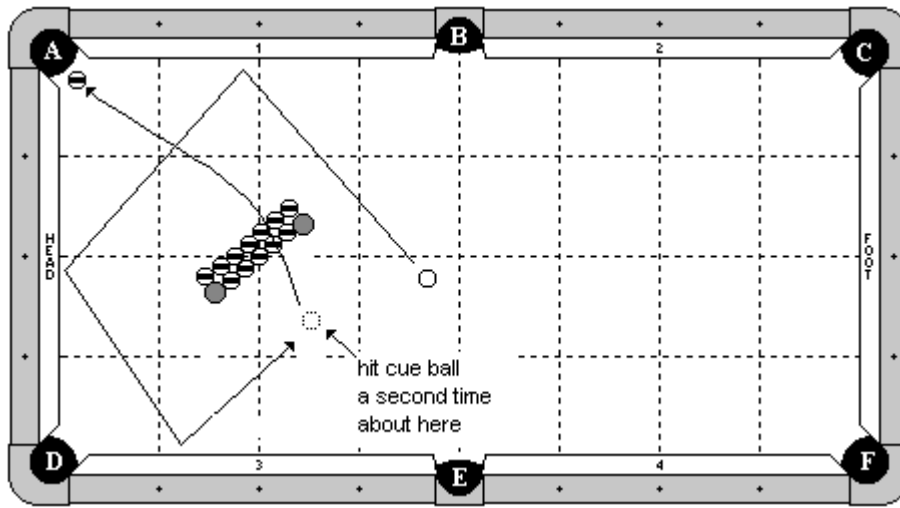

Category

Jump / Juggling

Difficulty: 9

Cue Ball

In hand

Object Ball

12 blocking balls are frozen in line as diagrammed. The middle ball of the back line (the line with the bottles) is on the head spot. The row with the bottles has 5 balls. The other line has 7 balls. An object ball is hanging near pocket A.

Props

2 bottles are placed at either end of the row of 5 balls as diagrammed. The bottles are frozen to the end balls.

Objective

Shoot the cue ball 3 rails as diagrammed. While the cue ball is moving, the player must jump it over the row of balls (between the bottles) and pocket the ball in pocket A.

Special Notes

All hits on the cue ball must be done one handed and free handed. The cue ball cannot fly off the table. The blocking balls and bottles may not be contacted by any means until after the object ball is made. The cue ball must be moving when hit a second time.

Shot 12

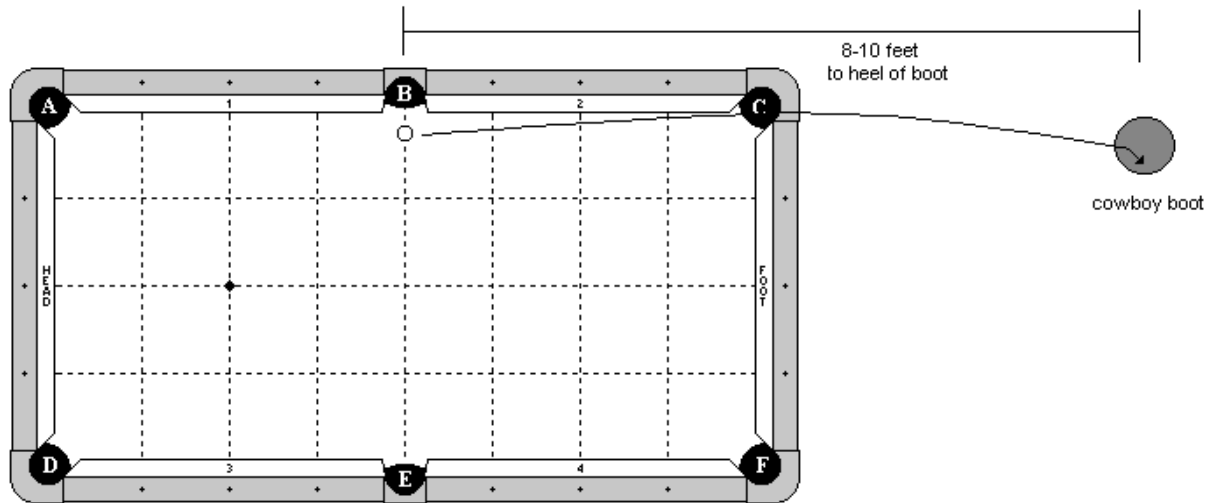

Category

Jump

Difficulty: 10

Cue Ball

Near pocket B, along center line of table.

Object Ball

None

Props

A standard boot is placed on the floor with the heel between 8 and 10 feet from the floor directly below the center line of the table. The boot may be angled by putting any object under the boot.

Objective

Jump the cue ball on the fly into the boot. It may not bounce or hit anything except the boot. The boot may fall over, but the cue ball (base of the ball) must remain in the boot.

Special Notes

Players are free to use any boot, but it may not exceed a size 13 boot.

Shot 13

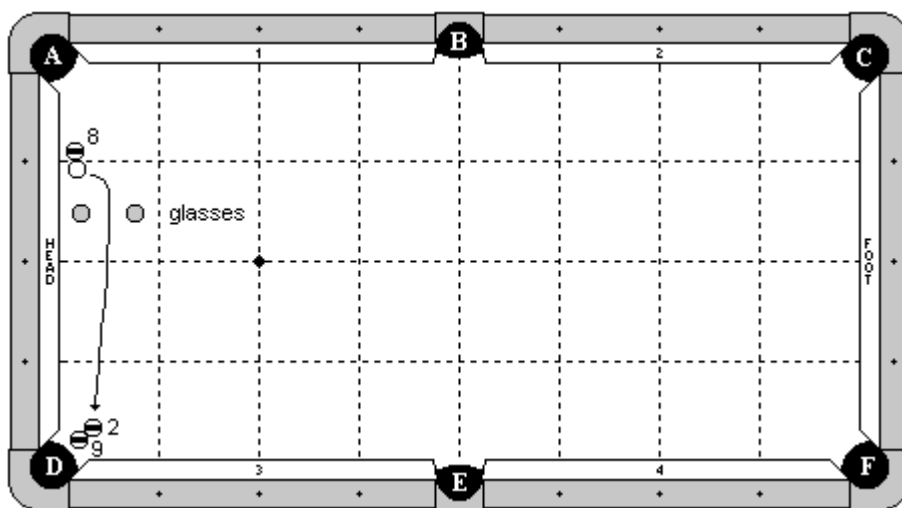

Category

Masse

Difficulty: 9

Cue Ball

In hand, frozen to the 8 ball. It may not be more than 1 ball's width off the cushion.

Object Ball

8-ball is in hand, frozen to the cue ball. The 2-9 combination is at pocket D, with the 9 ball centered between the pocket points.

Props

Two glasses (between 2 1/2 and 3 inches in diameter at the base) are on the 1 1/2 diamond line. The first glass is 1 ball's width off the cushion. The second glass is 3 ball's width from the first glass.

Objective

Masse the cue ball off the 8-ball (the 8-ball must move). The cue ball will travel between the glasses, making the 2-9 combination.

Special Notes

Both the cue ball and 8-ball may be adjusted slightly, but they must be positioned as diagrammed. The 8-ball does not have to be made. The glasses may not be contacted by any means until after the 9-ball is made.

Shot 14

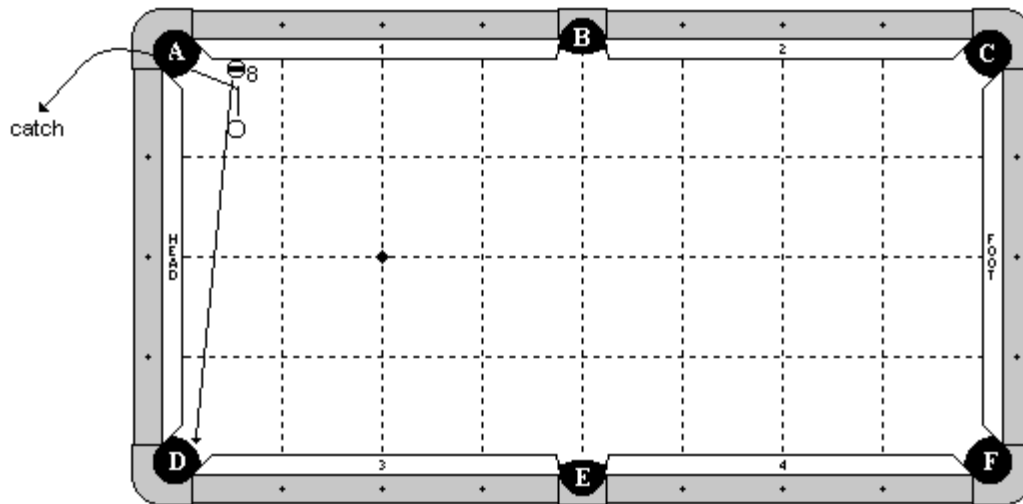

Category
Miscellaneous

Difficulty: 8

Category
Miscellaneous

Cue Ball
In hand

Object Ball
The 8 ball is frozen to cushion 1, within 1 diamond from pocket A.

Props
None

Objective
Bank the 8 ball into D pocket. The cue ball must jump in the air and you must catch the cue ball before it falls and contacts anything.

Special Notes
None

Shot 15

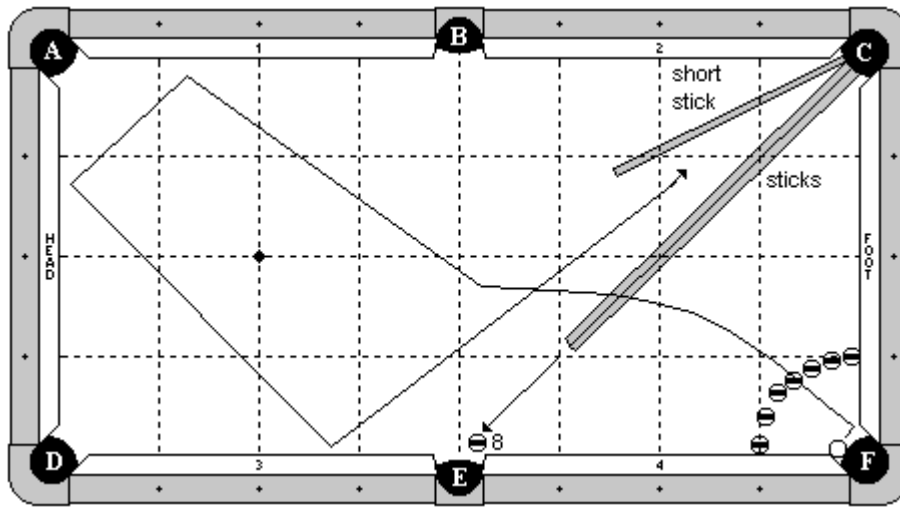

Category

Miscellaneous

Difficulty: 8

Cue Ball

Inside the jaws of F pocket, no more than $\frac{1}{2}$ ball's width past the pocket point.

Object Ball

8 ball hanging near E pocket. A ring of 7 blocking balls are evenly spaced around pocket F, with the end balls frozen to the 1st diamond on their cushion.

Props

Three cues are placed as indicated. One of the cues (indicated) may be a shorter cue.

Objective

Shoot the cue ball into the point of pocket F. Jump over the ring of balls, travel 3 cushions as indicated, go up the sticks and back down (standard railroad shot), making the 8 ball in pocket E.

Special Notes

The ring of balls may not be contacted by any means until after the 8 ball is made.

Shot 16

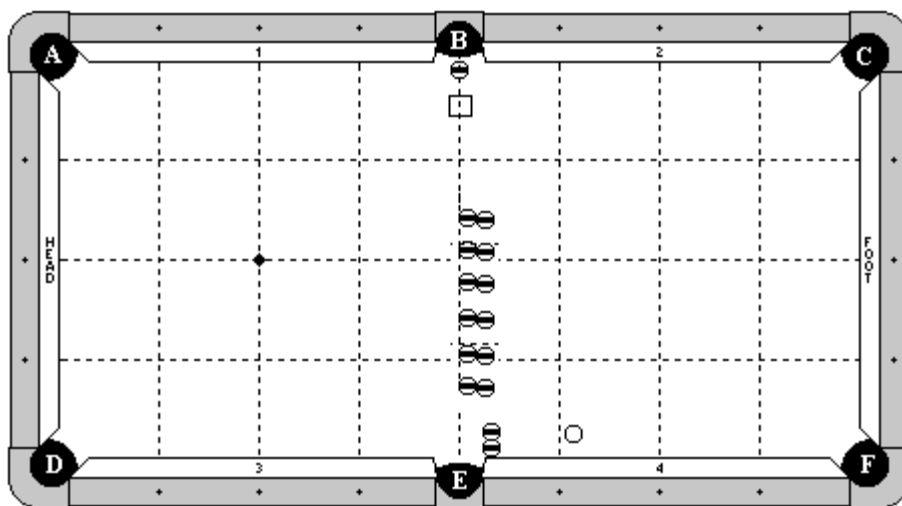

Category

Miscellaneous

Difficulty: 8

Cue Ball

In hand.

Object Ball

2 object balls are frozen in line near pocket E. 6 clusters of 2 balls are frozen to each other in pairs of 2 and are positioned as diagrammed. An object ball is hanging near pocket B. All balls may be adjusted by the player.

Props

A small paper bag is placed between the last cluster of 2 balls and the hanging ball near pocket B.

Objective

Shoot the cue ball into the outside object ball. The object ball frozen to the cushion will start to bank across the table. The cue ball will hit the first cluster of 2 balls, causing all of them to split apart as in the standard football shot. The banking object ball will travel between all of the splitting pairs of balls, through the bag (causing it to flip over) and finally pocket the hanging ball in pocket B.

Special Notes

None

Shot 17

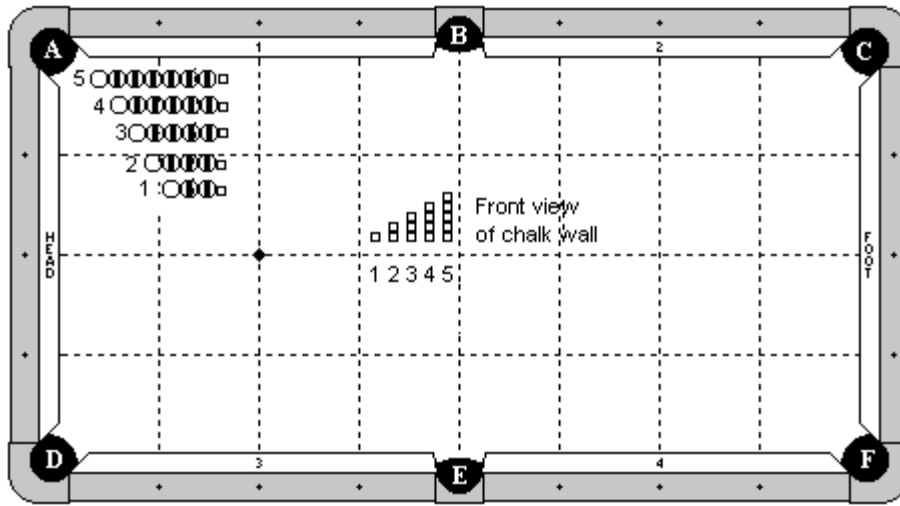

Category

Jump / Speed

Difficulty: 10

Cue Ball

None

Object Ball

- 1 ball: 2 ball's width from the chalk, directly in line with the chalk and pocket C
- 2 ball: 3 ball's width from the chalk, directly in line with the chalk and pocket C
- 3 ball: 4 ball's width from the chalk, directly in line with the chalk and pocket C
- 4 ball: 5 ball's width from the chalk, directly in line with the chalk and pocket C
- 5 ball: 6 ball's width from the chalk, directly in line with the chalk and pocket C

Props

Chalk cubes are in a straight line (perpendicular to cushion 1). The chalk in front of the 1 ball is 1 chalk cube high. The chalk in front of the 2 ball is 2 chalk cubes high. The 3 ball has a tower of 3 chalk cubes. The 4 ball has a tower of 4 chalk cubes. The 5 ball has a tower of 5 chalk cubes.

Objective

Jump the object balls in numerical order over their corresponding chalk cube(s), and into pocket C. This shot must be performed in a maximum of 10 seconds.

Special Notes

The chalk cubes may not be contacted by any means. The timer starts when the first ball is hit and the timer stops when the last ball is hit.

Shot 18

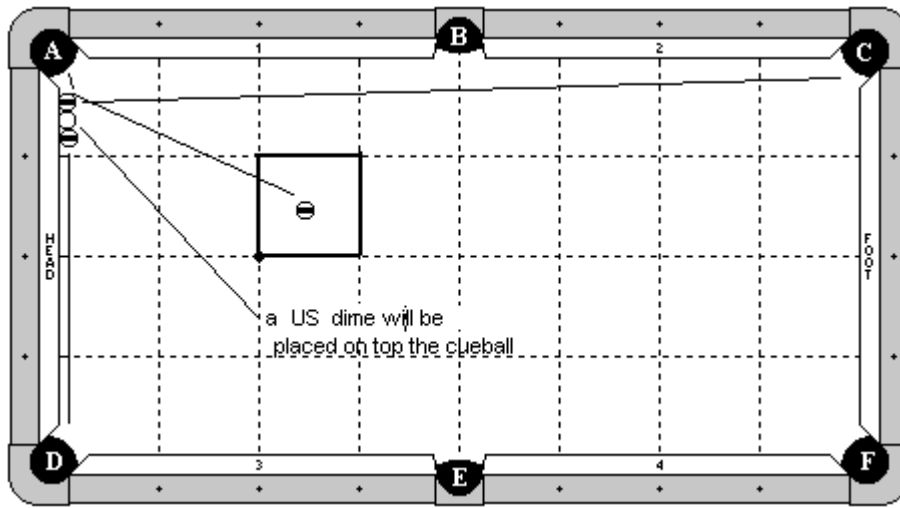

Category

Miscellaneous

Difficulty: 7

Cue Ball

In hand, frozen to the cushion and to both object balls.

Object Ball

Two object balls are in hand. The object ball closest to pocket A is frozen to the cue ball and to the cushion. The other object ball is frozen to the cue ball but does not need to be frozen to the cushion. A third object ball is in hand within the indicated zone.

Props

A US dime is balanced on top of the cue ball.

Objective

Shoot the object ball in the zone off the object ball near pocket A. The struck object ball will carom off and go into pocket A. The object ball that is hit first will bank down into pocket C. The other object ball will travel along the head cushion into pocket D.

Special Notes

The dime must remain on the cue ball. It may not fall off.

Shot 19

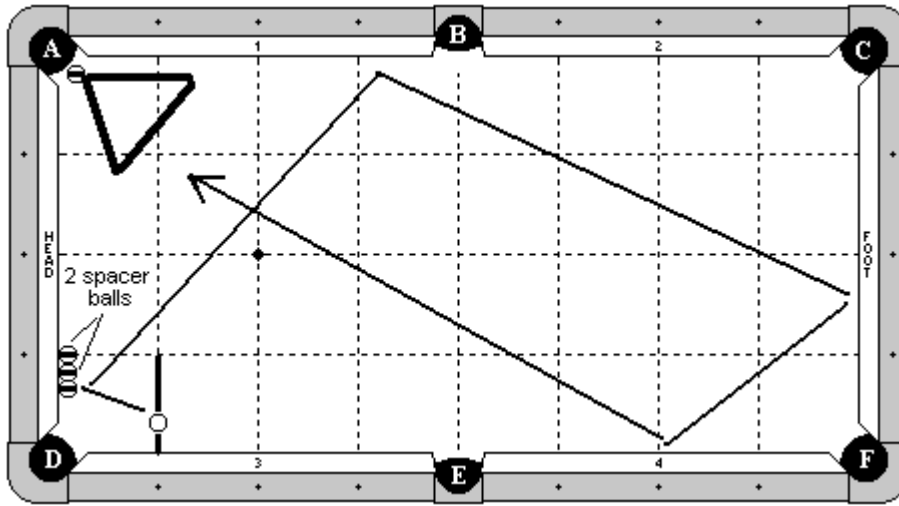

Category

Miscellaneous

Difficulty: 8

Cue Ball

In hand on the 1st diamond line, no more than 1 diamond off cushion 3.

Object Ball

An object ball is placed 2 ball's width from the 1st diamond. Two spacer balls are shown in the diagram, but are removed for the actual shot. Another object ball is hanging near pocket A.

Props

A rack is placed frozen to the object ball near pocket A.

Objective

Shoot the cue ball into the object ball. Double kiss back 3 rails as diagrammed, and hit the rack, making the object ball in pocket A.

Special Notes

It is okay if the cue ball catches an extra rail near the rack. It is okay if the cue ball goes behind the rack and makes the object ball on its own.

Shot 20

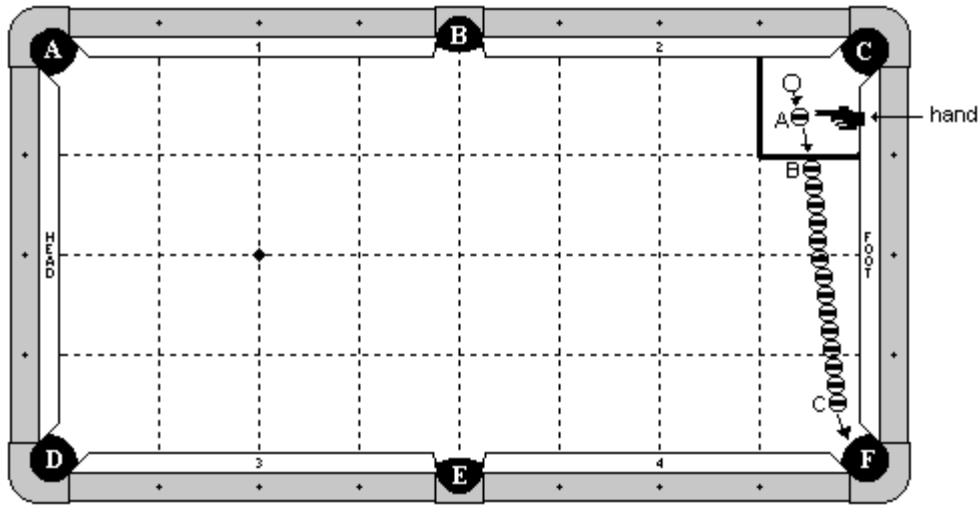

Category

Miscellaneous

Difficulty: 9

Cue Ball

In hand in the indicated zone.

Object Ball

Ball 'A' is in hand within the indicated zone. A line of 14 balls is as diagrammed, with 'B' ball's edge on the 1st diamond line.

Props

None

Objective

Shoot the cue ball into 'A' ball. Quickly grab 'A' ball with your hand before it hits any ball in the line. The cue ball will follow into 'B' ball, making the 14-ball combination, causing C ball to go into pocket F.

Special Notes

The player's hand may not disturb any of the balls in the line, and it may not hit the cue ball. The cue ball, 'A' ball, and 'B' ball must all be in a straight line. The cue ball may not hit the cushion before hitting B ball.

Shot 21

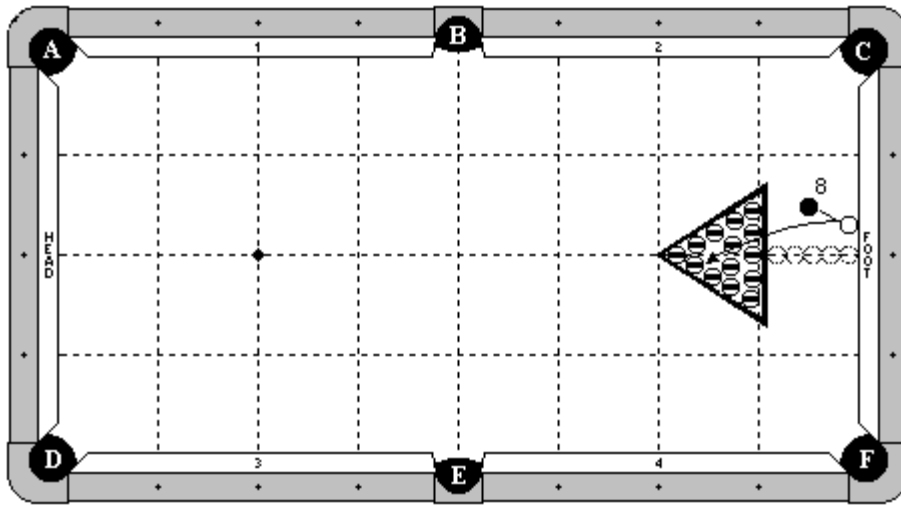

Category

Miscellaneous

Difficulty: 9

Cue Ball

Frozen to the foot cushion, adjustable.

Object Ball

8-ball is in hand. 14 object balls are in the rack, which is in normal racking position. The empty position is the exact center of the rack.

Props

A rack is around the 14 balls, in normal racking position.

Objective

Shoot the 8-ball into the cue ball. The 8-ball will double kiss back and jump into the gap in the balls in the rack.

Special Notes

None

Shot 22

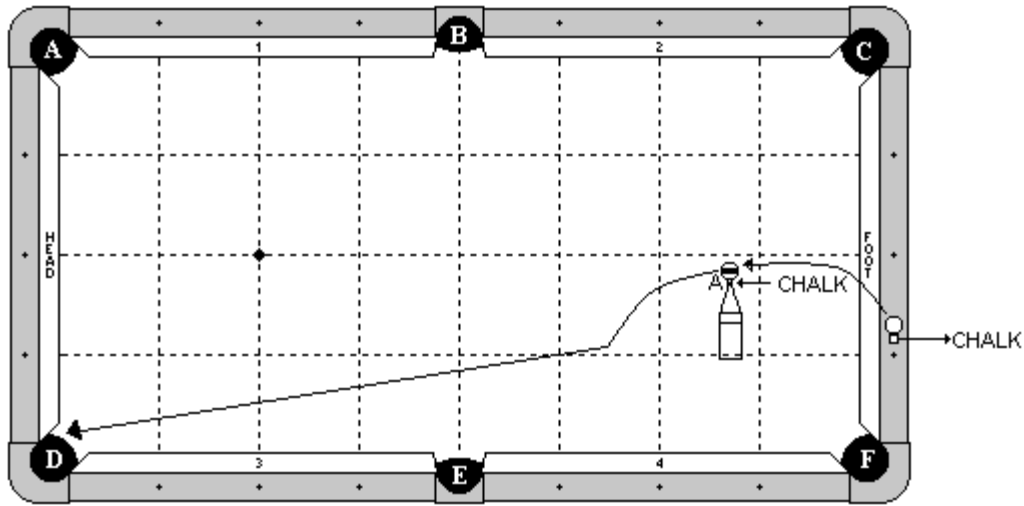

Category

Miscellaneous

Difficulty: 7

Cue Ball

In hand, balanced on a piece of chalk.

Object Ball

Balanced on top of a bottle.

Props

A plastic bottle is in hand with an object ball balanced on top of it. A piece of chalk is in hand on the rail top, with the cue ball balanced on it. The bottle is a standard 12 or 16 ounce plastic soda bottle.

Objective

Shoot the cue ball up into the object ball. The object ball will fly off the bottle and go into pocket D.

Special Notes

The bottle may not fall over by any means.

Shot 23

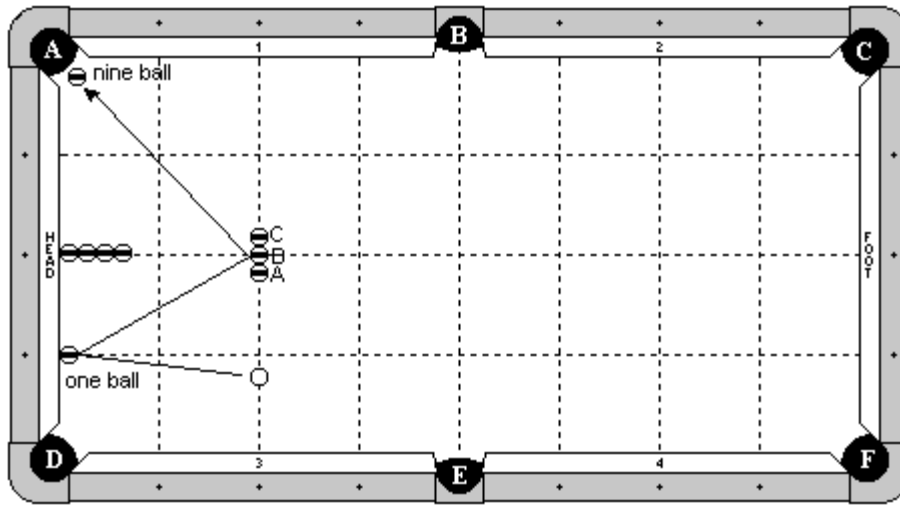

Category

Miscellaneous

Difficulty: 9

Cue Ball

In hand along the 2nd diamond line.

Object Ball

1 ball is frozen to the head cushion at the 1st diamond. Balls A,B,C are in line and frozen along the 2nd diamond line with B ball on the head spot. 4 blocking balls are lined up and frozen along the long center line of the table, with the first ball being frozen to the head cushion. The 9 ball is hanging near pocket A.

Props

None

Objective

Shoot the cue ball into the 1 ball. The cue ball will double kiss back, hit the cluster of 3 balls (A,B,C), and then follow into the 9-ball making it in pocket A.

Special Notes

The blocking balls may not be touched until after the 9-ball is made.

Shot 25

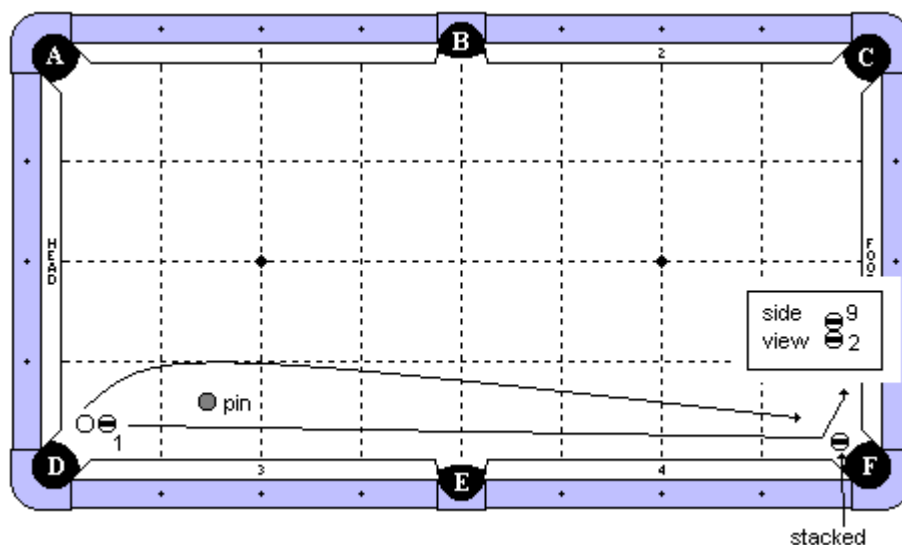

Category

Stroke

Difficulty: 9

Cue Ball

In hand, no more than 1/8 inch away from the 1 ball.

Object Ball

The 1 ball is in hand, no more than 1 ball's width from cushion 3. The 9 ball is balanced on top of a special stacking ball (2-ball).

Props

A pin or a normal plastic bottle is placed on the 1 1/2 diamond line, exactly 3 ball's width off the cushion. A special stacking ball (2-ball) is hanging near pocket F.

Objective

Shoot the cue ball into the 1 ball. The 1 ball will make the 2 ball and get out of the way. The cue ball will curve around the pin and make the 9 ball.

Special Notes

The pin may not be hit by any means until after all balls have been made.

Shot 26

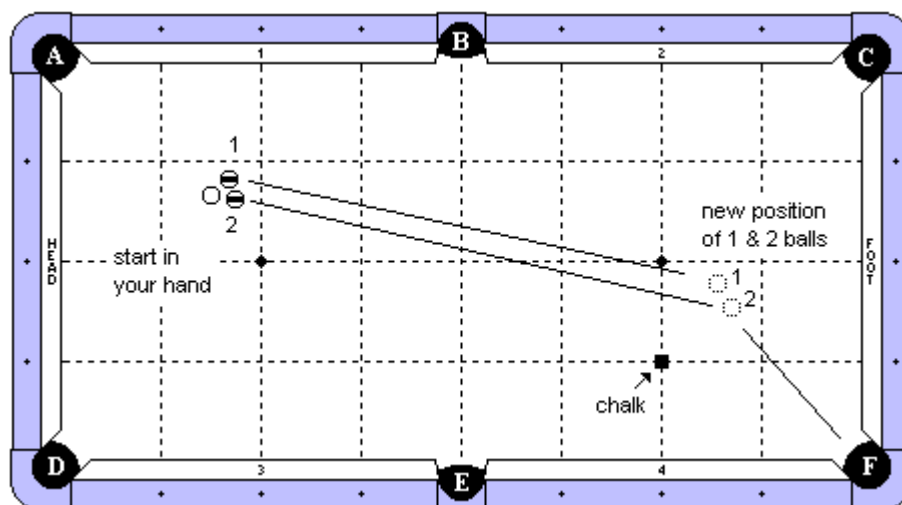

Category

Wing

Difficulty: 9

Cue Ball

Starts in the shooter's hand.

Object Ball

The 1 and 2 balls start in the shooter's hand.

Props

A piece of chalk is positioned on the foot string, 1 diamond from cushion 4.

Objective

Roll both the 1 and 2 balls down the table. The cue ball is then placed behind the head string. Shoot the cue ball towards the rolling 1 and 2 balls, hitting the 1 ball into the 2 ball, making the 2 ball in pocket F.

Special Notes

The chalk may not be hit by any means until after the 2 ball is made. The 1 and 2 balls must be rolling when hit. The cue ball must hit the 1 ball before either ball hits the foot cushion.

Shot 27

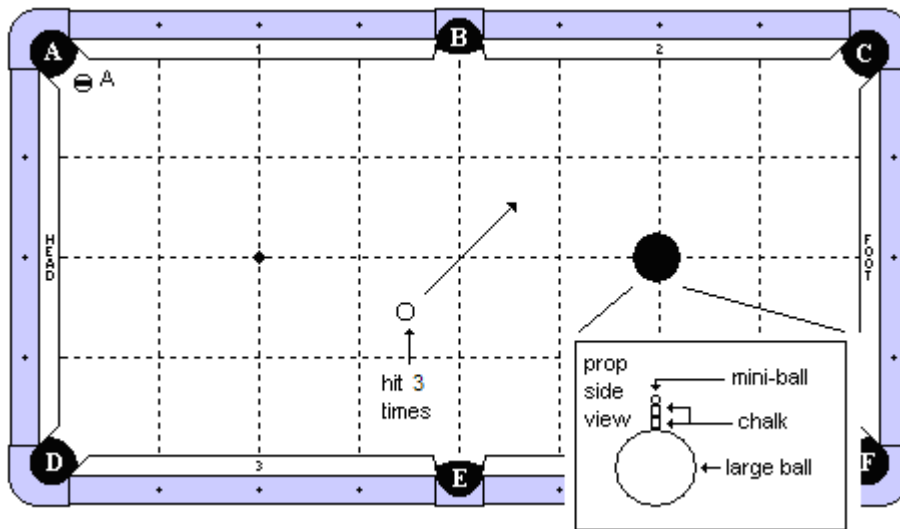

Category

Juggling

Difficulty: 7

Cue Ball

In hand

Object Ball

'A' ball is hanging near pocket A.

Props

A large Aramith cue ball is on the foot spot. Two chalks are balanced on top of it, and a mini pool ball is on top of the chalks. Players have the option of using a 6 pound bowling ball instead of the large Aramith ball.

Objective

Shoot the cue ball three cushions around the large ball. When the cue ball comes around, hit it again another three rails. The cue ball will come around and hit it again another three rails. This time, the cue ball will continue to make the 'A' ball in pocket A. The cue ball will hit a total of 9 cushions for this shot and it will be hit a total of 3 times.

Special Notes

The large obstacle ball may not be contacted by any means until 'A' ball is made. The chalks and mini pool ball may not fall off the large ball by any means until 'A' ball is made. It is okay for the cue ball to contact an extra rail near pocket A. The cue ball must be moving when re-hit every time.

Shot 28

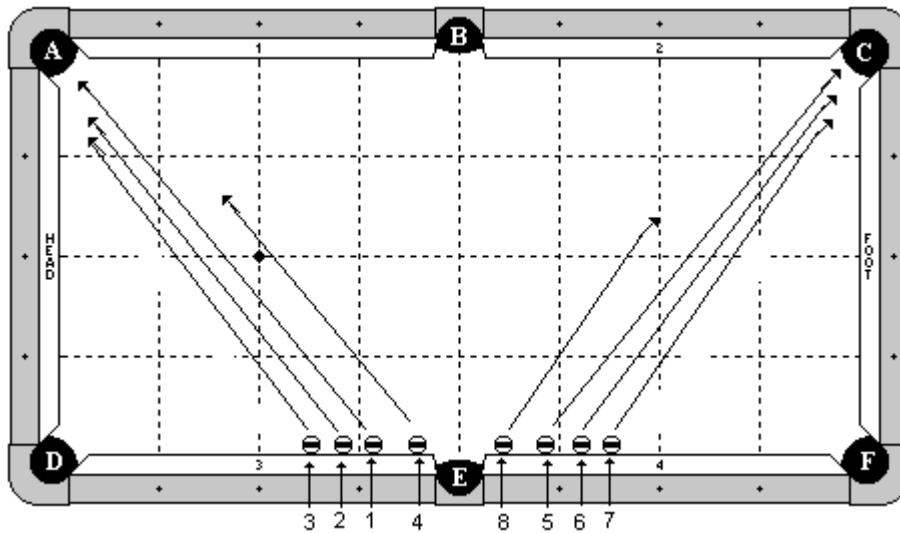

Category

Speed

Difficulty: 7

Cue Ball

None

Object Ball

Object balls 1 through 8 are in position as diagrammed. The gap between the 4 and the 1 and the gap between the 5 and the 8 are 3 ball's width. The gaps between the other balls is 1 ball's width.

Props

None

Objective

Shoot the 4 ball towards pocket A. Shoot the 1,2,3 balls in order into pocket A. The 4 ball will go last in pocket A. Repeat on the other side, starting with the 8 ball, and then shooting the 5,6,7 balls (the 8 ball will go last in pocket C).

Special Notes

None

Shot 29

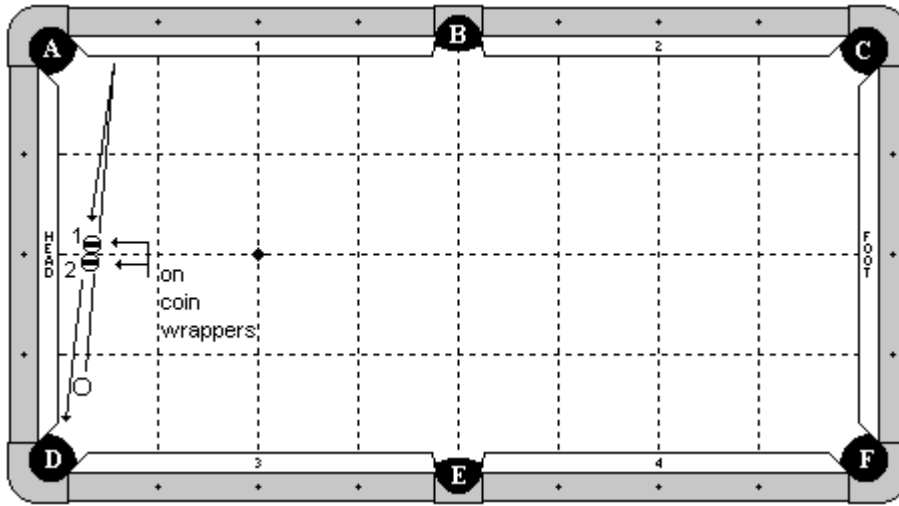

Category
Miscellaneous

Difficulty: 6

Cue Ball
In hand

Object Ball
The 1 and 2 balls are in hand on coin wrappers.

Props
2 coin wrappers are under the object balls.

Objective
Shoot the cue ball under the balls, knocking away the coin wrappers and causing the balls to fall in place. The cue ball will bank off cushion 1, come back and hit the 1 ball, causing the 2 ball to go into pocket D.

Special Notes
None

Shot 30

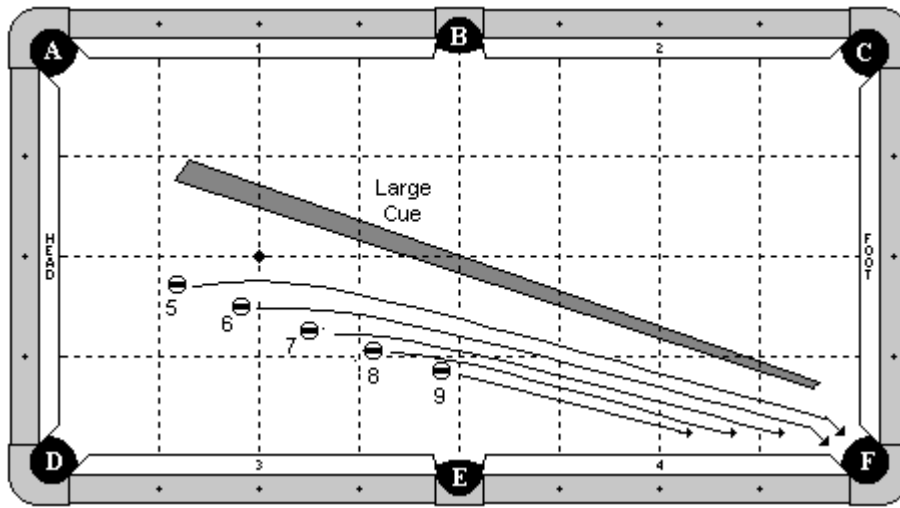

Category

Jump

Difficulty: 8

Cue Ball

None

Object Ball

The 5 through 9 balls are in a straight line towards pocket F.

Props

A large cue (made by Stealth) is on the table, about 6 inches away from the line of balls. Players are free to use a regular shooting cue in place of the large cue.

Objective

Jump the 5 ball over the other balls into pocket F. Jump the 6 ball, then the 7, then the 8 ball over the remaining balls into pocket F. Pick up the large cue and shoot the 9 ball straight into pocket F.

Special Notes

When shooting the 5,6,7,8 balls, the balls being jumped over and the cue may not be contacted by any means. Player must use a dart style jump stroke when shooting this shot.

Shot 31

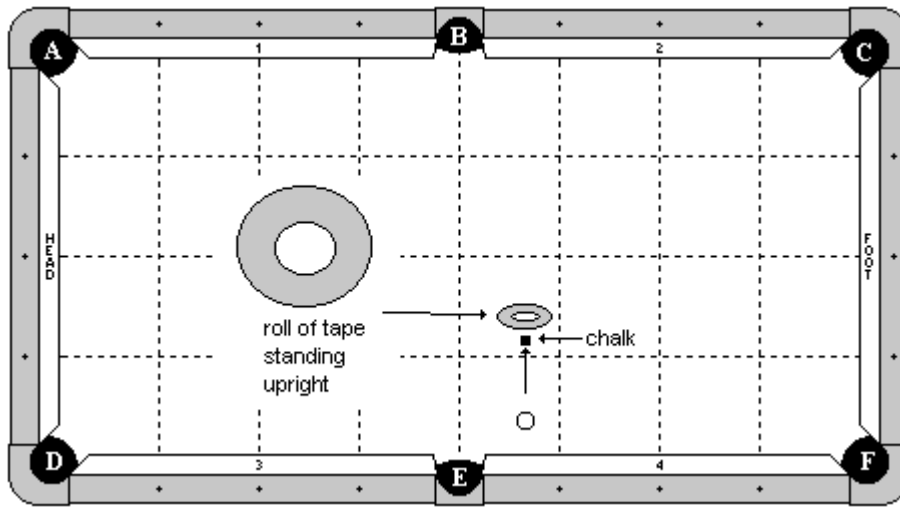

Category

Jump

Difficulty: 7

Cue Ball

In hand

Object Ball

None

Props

A roll of blue painters tape is standing upright on its edge. The hole of the tape is facing the cue ball. A chalk cube is 1 chalk's width away from the tape and centered, directly in line with the cue ball and the center of the tape. The dimensions of the tape are as follows:

Outside Diameter: Between $3 \frac{7}{8}$ and $4 \frac{1}{8}$ inches.

Inside Diameter of Hole: Between $2 \frac{7}{8}$ and $3 \frac{1}{8}$ inches.

Width of Tape: Between $2 \frac{7}{8}$ and $3 \frac{1}{8}$ inches.

Objective

Jump the cue ball over the chalk. The roll of tape will fall over and the cue ball will be trapped within the center hole.

Special Notes

The roll of tape may not contact any cushion. The chalk may not be contacted by any means.

Shot 32

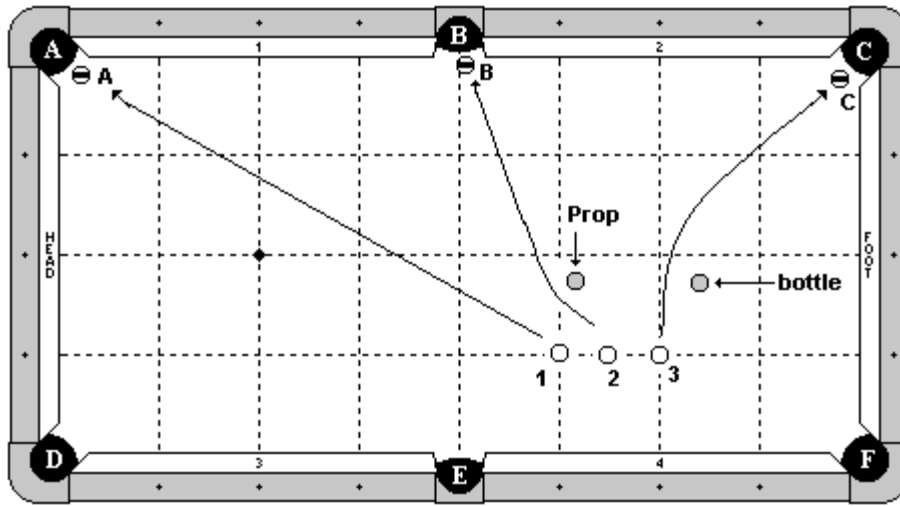

Category

Jump / Masse / Speed

Difficulty: 9

Cue Ball

Three cue balls are used for this shot. All are on the 1st diamond line. Cue ball 1 is at the 3rd diamond, cue ball 2 is at the 2 ½ diamond, and cue ball 3 is at the 2nd diamond.

Object Ball

Object balls A, B, and C are hanging near their corresponding pockets.

Props

A bottle is placed exactly 3 ball's width from cue ball 3, directly in line with the C ball. Any prop that is no taller than a pool ball (2 ¼ inches) is placed exactly 3 ball's width from cue ball 2, directly in line with the B ball. Players may not use a pool ball for this prop. This prop must be a minimum of 1 ½ inches tall.

Objective

Shoot cue ball 1, making 'A' ball. Jump cue ball 2 over the prop, making B ball. Masse cue ball 3 around the bottle, making C ball. Each shot must be done with a different cue stick. For example, cue ball 1 would be hit with a regular shooting cue, cue ball 2 would be hit with a jump cue, and cue ball 3 would be hit with a masse cue. Players do not have to use the specific types of cue sticks specified in this example, but they must use three different cue sticks, one for each cue ball.

Special Notes

Players will have 6 seconds to execute this shot. The blocking prop and the bottle may not be contacted by any means until after all three balls have been made.

Shot 33

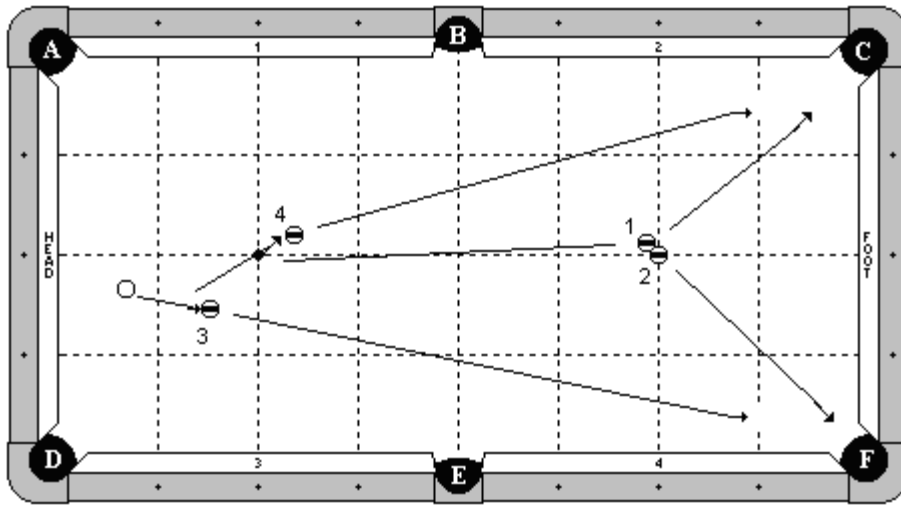

Category

Miscellaneous

Difficulty: 9

Cue Ball

In hand

Object Ball

Ball 2 is on the foot spot. Ball 1 is in hand frozen to the 2 ball. Ball 3 is in hand between the 1st and 2nd diamond (long rail diamonds). Ball 4 is in hand between the 2nd and 3rd diamond (long rail diamonds).

Props

None

Objective

Shoot the cue ball into the 3 ball, causing it to roll towards pocket F. Hit the cue ball again into the 4 ball, causing it to roll towards pocket C. Then shoot the cue ball into the 1 ball, causing the 1 ball to go into pocket C and the 2 ball into pocket F. The 3 and 4 balls will then go into pockets F and C respectively.

Special Notes

The 3 ball must go in after the 2 ball, and the 4 ball must go in after the 1 ball. The cue ball may not be repositioned manually by the player after each shot. It must be hit where it is.

Shot 34

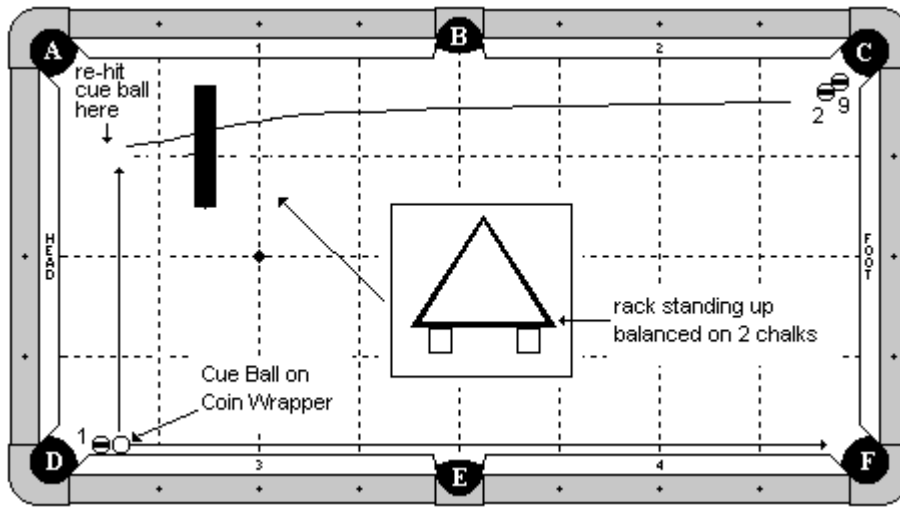

Category

Jump / Juggling

Difficulty: 9

Cue Ball

On top of a coin wrapper, $\frac{1}{2}$ diamond from pocket D.

Object Ball

The 1 ball is frozen to cushion 3, and in hand between the coin wrapper and pocket D.

The 2-9 combination is near pocket D.

Props

A coin wrapper is under the cue ball at $\frac{1}{2}$ diamond. The coin wrapper must be frozen to the cushion. A rack is propped up on its side and is standing on 2 chinks (1 on each side). The edge of the rack is 2 ball's width from the cushion, and the rack is along the $1 \frac{1}{2}$ diamond line.

Objective

Shoot the 1 ball under the cue ball, into pocket F. The cue ball will fall straight down and hit the cushion, causing it to bounce and roll in the indicated direction. Before the cue ball hits cushion 1, jump it through the rack, making the 2-9 combination.

Special Notes

The rack may not be contacted by any means until after all balls have been made. When shooting the 1 ball into the coin wrapper, the cue ball must fall straight down into the cushion. It may not fall to the side.

Shot 35

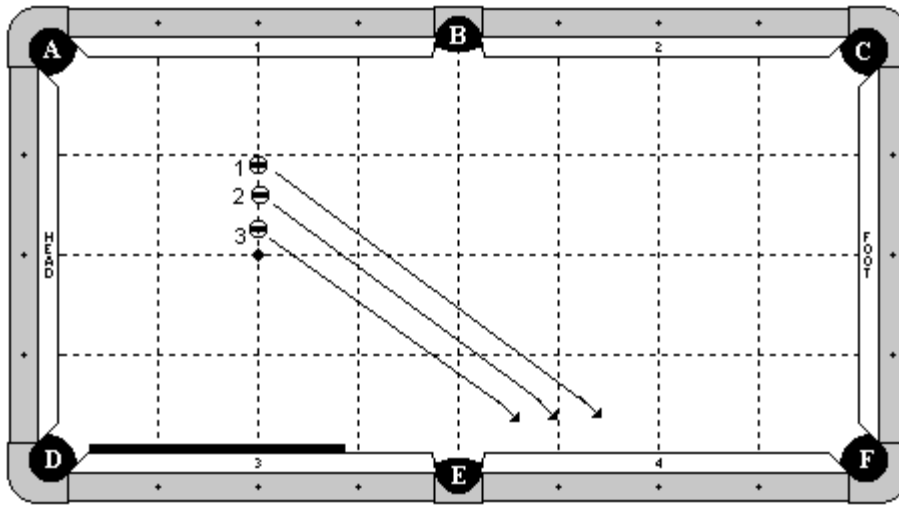

Category

Juggling

Difficulty: 8

Cue Ball

None

Object Ball

The 1, 2, and 3 balls are in hand on the 2nd diamond line. They must be placed to the left of the head spot and in the order in which they appear in the diagram.

Props

A cue stick butt is placed frozen to cushion 3.

Objective

Hit the 1, then the 2, then the 3 in the direction indicated by the diagram. The balls will all travel 3 rails. Then the balls come around, re-hit each of them in numerical order. They will all then travel 3 rails again, and go into pocket D. The cue stick may help guide the balls into the pocket.

Special Notes

The object balls may not stop in the middle of the shot. All re-hits must be done while the object balls are moving. All 3 balls must be hit and re-hit and made in numerical order. The balls may not contact each other at any time until after all of them have been hit and re-hit. This will be a timed shot. All 3 balls must be hit and re-hit within 12 seconds. Time will start when the 1 ball is first hit. Time will stop when the 3 ball is hit for the second time.

Shot 36

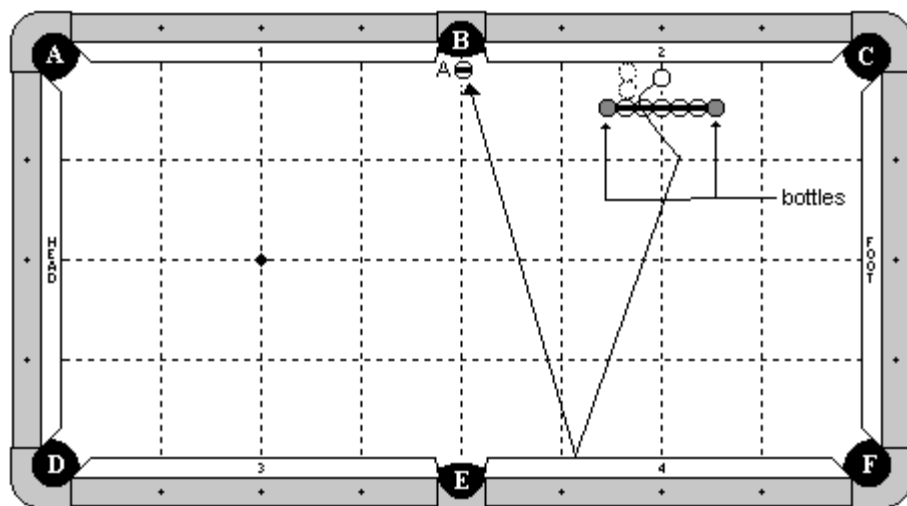

Category

Jump

Difficulty: 8

Cue Ball

In hand on the 2nd diamond line, between the row of balls and the cushion.

Object Ball

5 blocking balls are 2 ball's width away from the cushion and in a straight line. All are frozen to each other. Another ball is hanging near pocket B.

Props

Two bottles are frozen to each end of the line of balls.

Objective

Jump the cue ball over the line of balls, between the bottles, bank it one cushion, and make the ball hanging near pocket B.

Special Notes

None

Shot 37

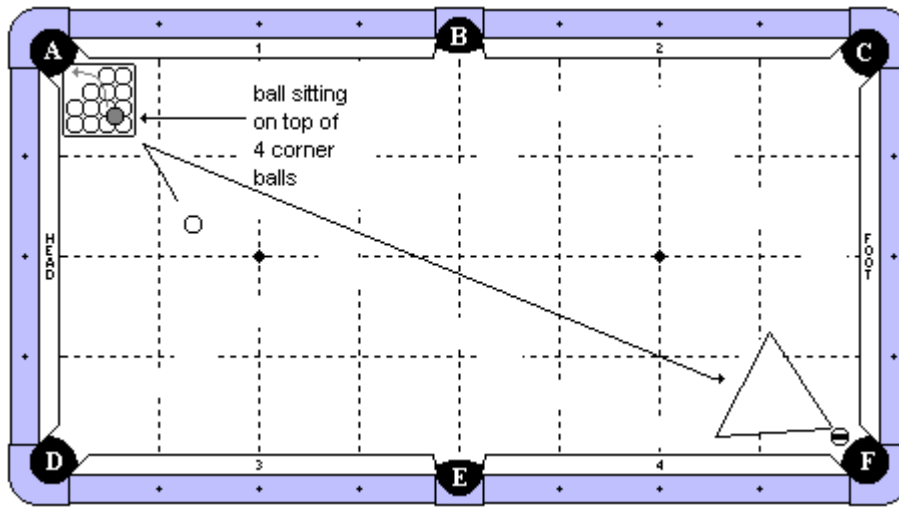

Category

Miscellaneous

Difficulty: 7

Cue Ball

In hand

Object Ball

13 object balls are in the ball tray as diagrammed. An object ball is balanced on top of the first 4 balls in the tray. Another object ball is hanging near pocket F.

Props

A standard ball tray is used. It is hard plastic and has a flat edge to allow the cue ball to bounce off without jumping in the air. A rack is placed by the ball at pocket F as diagrammed. Players are allowed to use their own ball tray but it must be plastic.

Objective

Shoot the cue ball into the tray and make the ball that is sitting up on top into pocket A. The cue ball must draw back and go directly into the rack, making F ball.

Special Notes

The cue ball may not contact any rails before hitting the rack.

Shot 38

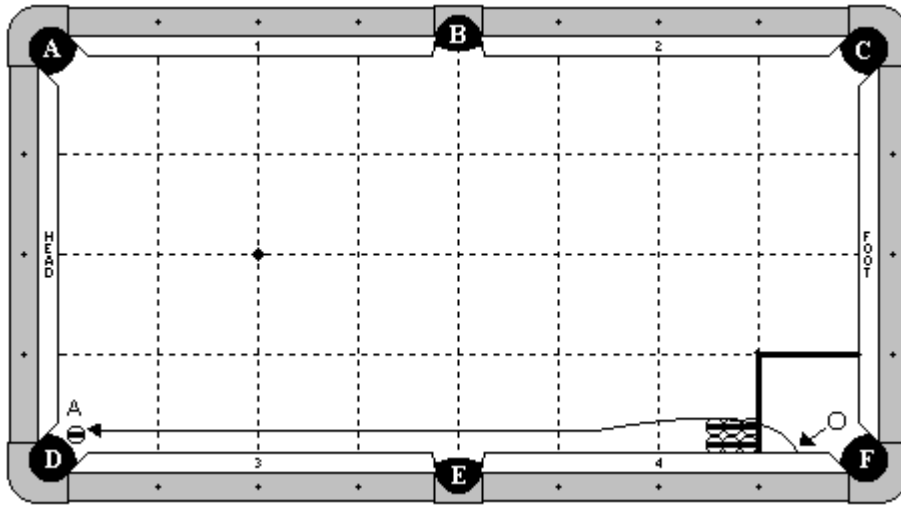

Category

Miscellaneous

Difficulty: 7

Cue Ball

In hand within the indicated zone.

Object Ball

6 blocking balls are all frozen to each other, with 3 of them frozen to the cushion as diagrammed. The first 2 balls have their edge even with the 1st diamond. Ball 'A' is hanging near pocket D.

Props

None

Objective

Shoot the cue ball into cushion 4, as the diagram indicates, causing the cue ball to jump over the blocking balls, and make ball 'A' in pocket D.

Special Notes

The blocking balls must not be touched by any means until after ball 'A' has been made.

Shot 39

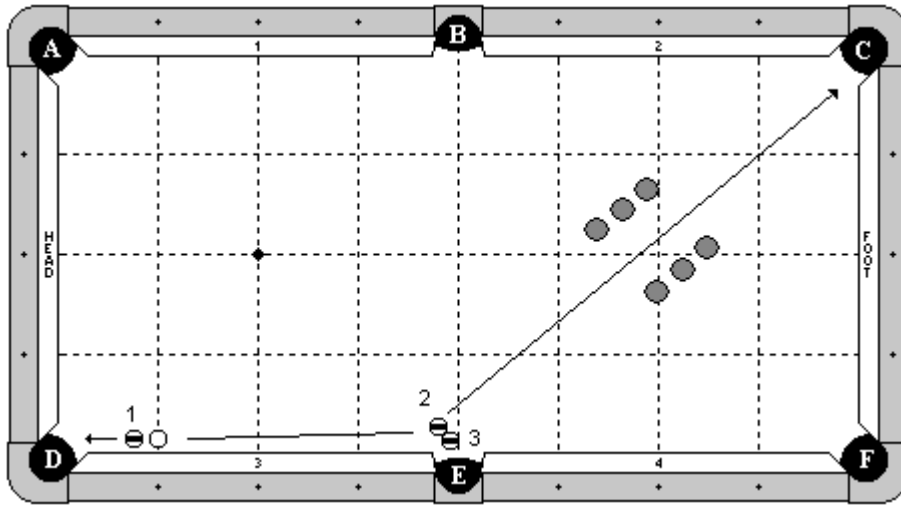

Category

Masse

Difficulty: 9

Cue Ball

In hand along the 1st diamond line from pocket D.

Object Ball

The 1 ball is in hand to the left of the cue ball. The 2 and 3 balls are as diagrammed near pocket E, and may be adjusted by the player.

Props

6 bottles are as diagrammed near the foot spot. The rows of 3 bottles have a gap of about 2 inches between each bottle. The gap between the 2 rows is 3 ball's width.

Objective

Masse the cue ball, making the 1 ball in pocket D. The cue ball will travel up the rail, hitting the 2 ball. The 2 ball will go between the bottles and into pocket C, and the 3 ball will go into pocket E.

Special Notes

The bottles may not be touched by any means until after all balls have been made.

Shot 40

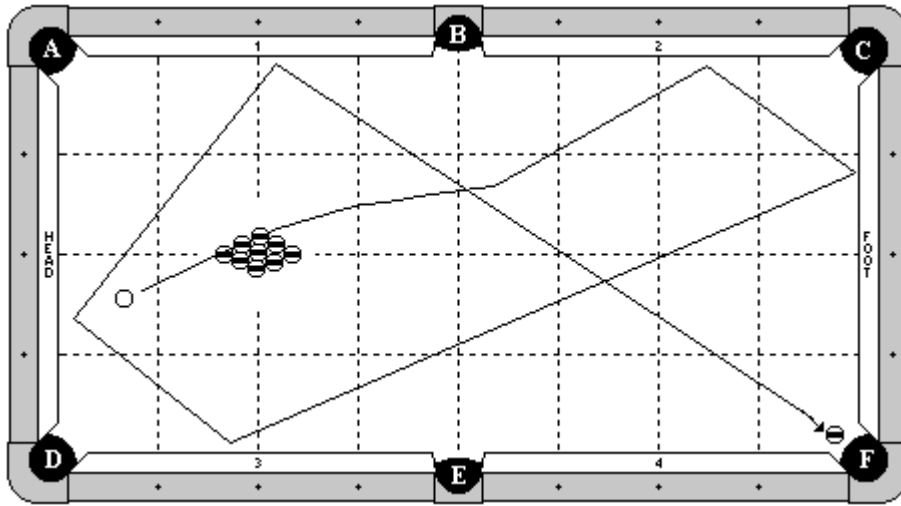

Category

Jump

Difficulty: 8

Cue Ball

In hand, but must meet the requirements listed in the 'special notes' section.

Object Ball

9 object balls are racked in the standard 9-ball formation. The center ball will be positioned on the head string, and the players are free to slide the entire setup left or right, provided the center ball of the rack remains on the head string. The rack will not be left around the balls. Another object ball is hanging near pocket F.

Props

None

Objective

Jump the cue ball over the rack of balls and have it travel 5 rails to make the hanging ball in pocket F.

Special Notes

The cue ball and the rack of balls must be positioned in such a way as to make the line of aim take the cue ball directly over the center ball of the rack. The cue ball may contact an extra cushion near pocket F.

Shot 41

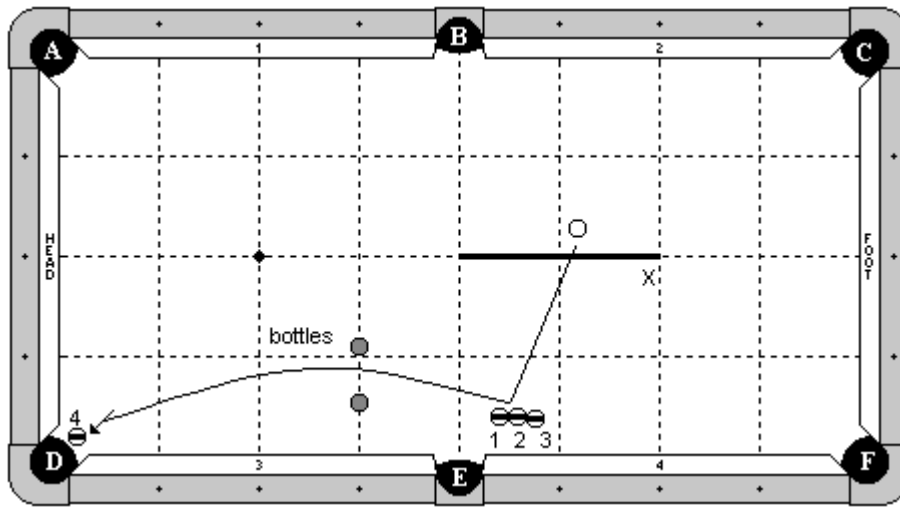

Category

Miscellaneous

Difficulty: 8

Cue Ball

In hand behind line X.

Object Ball

The 1 and 2 balls are frozen and exactly 2 ball's width from the cushion. They may be adjusted left or right. The 3 ball is frozen to the 2 ball and in hand. The 4 ball is hanging near pocket D.

Props

Two bottles are placed exactly 3 ball's width apart along the 3rd diamond. The bottle closest to the rail must be a minimum of 3 ball's width from the rail.

Objective

Shoot the cue ball into the cluster of 3 balls. The 1 ball will go into pocket E. The 2 ball will bank into pocket B. The 3 ball will go into pocket F. The cue ball will curve between the bottles, making the 4 ball in pocket D.

Special Notes

The cue ball may not contact the bottles until after the 4 ball is made.

Shot 42

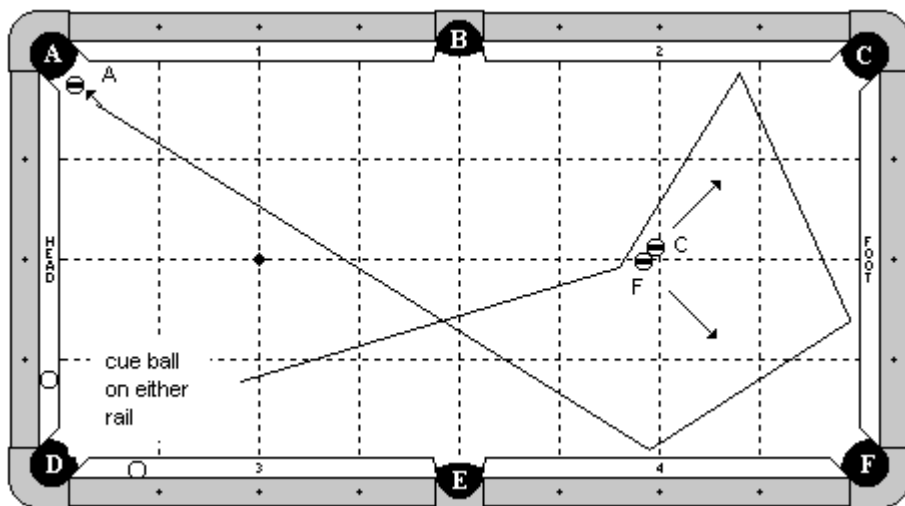

Category

Miscellaneous

Difficulty: 8

Cue Ball

In hand on top of either cushion 3 or the head cushion.

Object Ball

All object balls are as diagrammed and may be adjusted.

Props

None

Objective

Shoot the cue ball off the rail top. The cue ball will contact the 2 ball setup, making both balls as diagrammed. The cue ball will travel 3 cushions to make 'A' ball.

Special Notes

The cue ball may contact an extra cushion near pocket A.

Shot 43

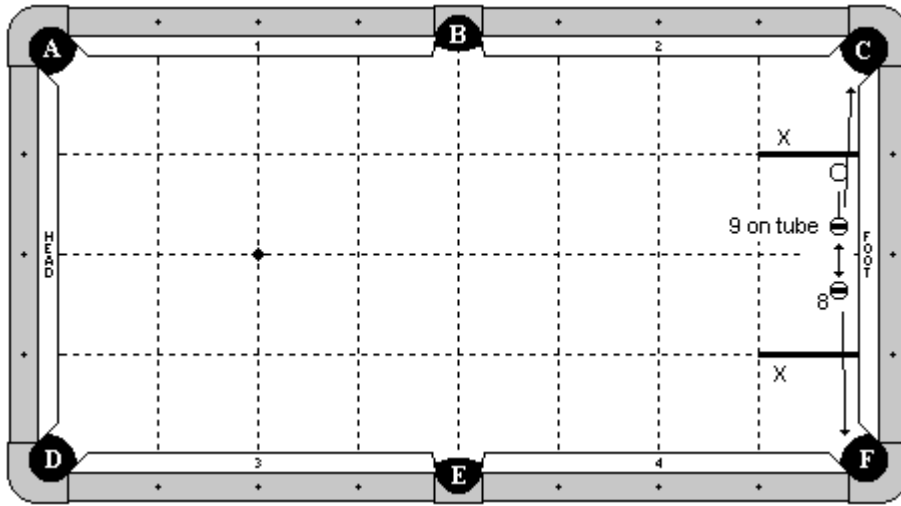

Category

Miscellaneous

Difficulty: 8

Cue Ball

In hand between the X lines.

Object Ball

8 ball in hand between the X lines. 9 ball balanced on top of a tube, also in hand between the X lines.

Props

A tube is used to prop up the 9 ball. It is in hand. The tube that I use is a rolled up index card with a rubber band around it. Players are free to use any tube or coin wrapper they want.

Objective

Shoot the cue ball under the 9 ball, making the 8 ball in pocket F. The 9 ball will fall. The cue ball will draw back, and make the 9 ball in C pocket.

Special Notes

The tube must be a minimum of 2 ball's width from both the cue ball and the 8 ball.

Shot 44

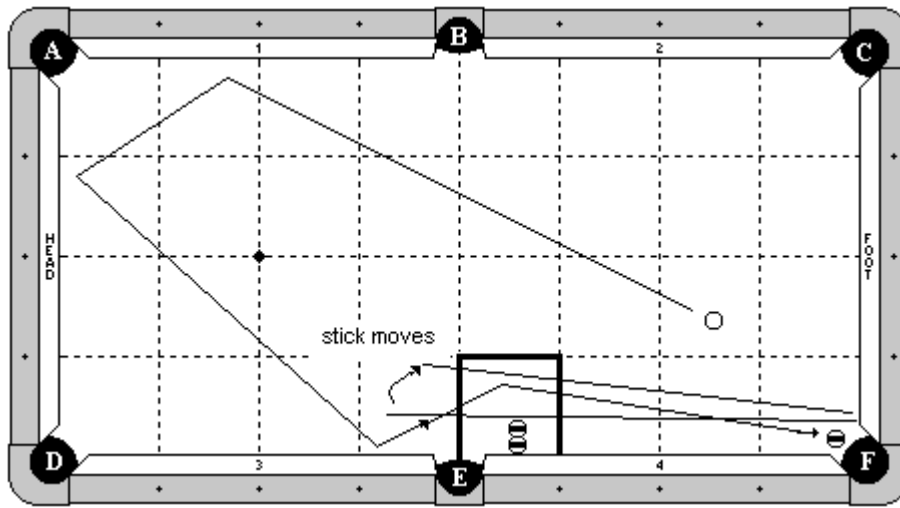

Category

Miscellaneous

Difficulty: 6

Cue Ball

In hand behind the foot string.

Object Ball

An object ball is hanging near pocket F. Two blocking balls are lined up straight across the table, frozen to each other, and one is frozen to the rail. They may be shifted anywhere within the indicated zone.

Props

A cue stick is placed on the table as diagrammed. The stick may not be more than $\frac{1}{2}$ inch from the outer of the two blocking balls.

Objective

Shoot the cue ball 3 rails as indicated by the diagram. The cue ball will contact the stick, which will slide out, allowing the cue ball to go around the blocking balls, making the object ball in pocket F.

Special Notes

The cue ball may not contact the blocking balls. The stick may not make the object ball in pocket F. The cue ball must make it.

Shot 45

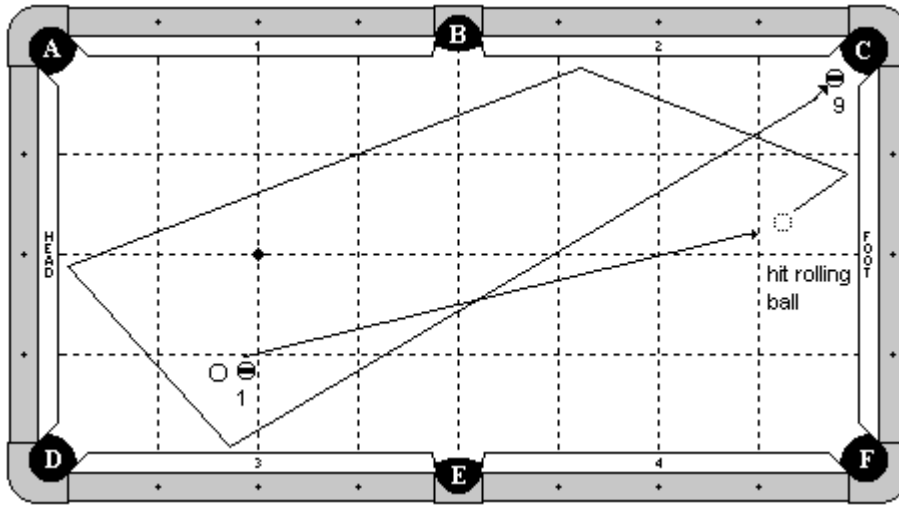

Category

Wing

Difficulty: 9

Cue Ball

Starts in your hand

Object Ball

The 1 ball starts in your hand. The 9 ball is hanging near pocket C.

Props

None

Objective

Roll the 1 ball down table and position the cue ball behind the head string. This is a standard wing shot except instead of making the 1 ball, the 1 ball is hit 4 cushions as diagrammed and will make the 9 ball.

Special Notes

The 1 ball may contact an extra cushion near pocket C. Both the cue ball and 1 ball must start in your hand. Extra contact between the cue ball and 1 ball is allowed as long as the 1 ball travels 4 rails as indicated, and makes the 9 ball. After rolling the 1 ball, the player must position the cue ball behind the head string. No guide may be used when rolling the 1 ball.

Shot 46

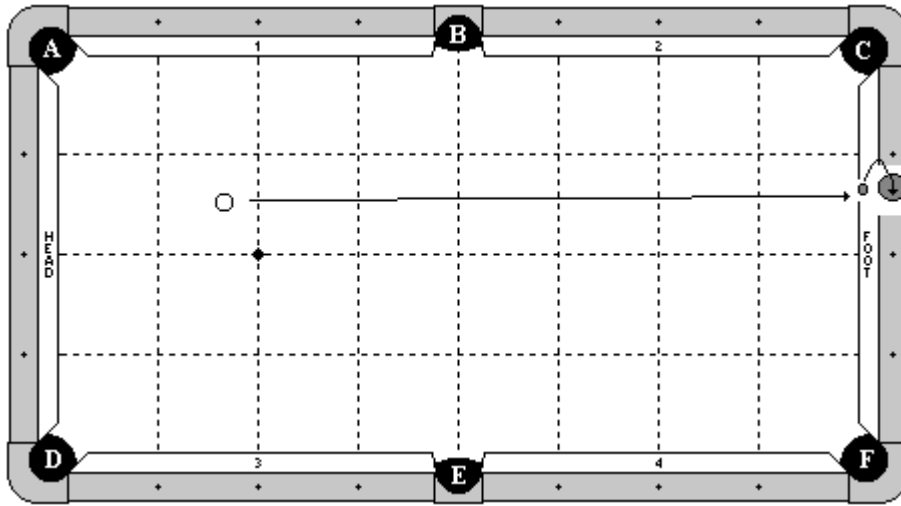

Category

Miscellaneous

Difficulty: 7

Cue Ball

In hand behind the head string.

Object Ball

None

Props

A coin is in hand on the foot cushion. A standard plastic shot glass is in hand on the foot cushion. Players may use any of the following coins: penny, nickel, dime, quarter.

Objective

Shoot the cue ball into the foot cushion, causing the coin to jump and land inside the shot glass.

Special Notes

None

Shot 47

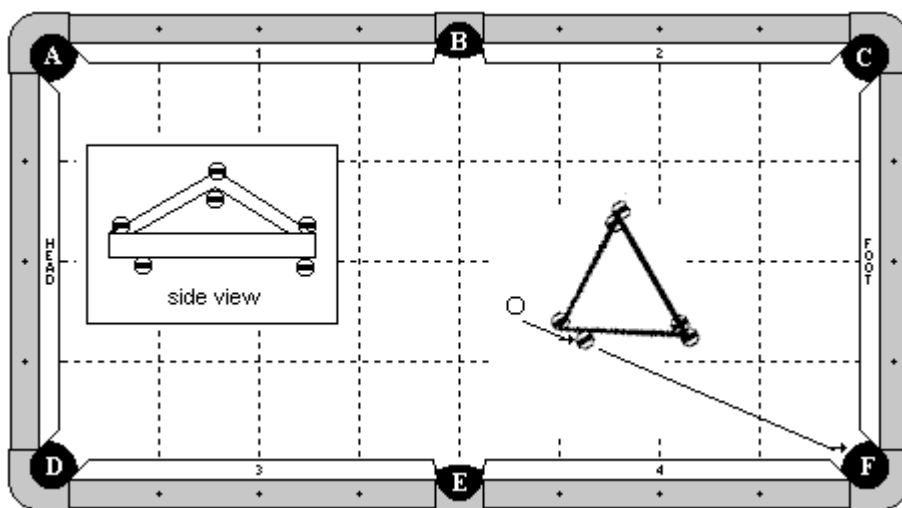

Category

Miscellaneous

Difficulty: 6

Cue Ball

In hand

Object Ball

3 object balls are positioned under to support a rack balanced on top of them. 2 of the 3 object balls are placed at the corners of the rack, and a 3rd object ball (the one that goes in pocket F) is offset slightly. 3 additional object balls are balanced on top of the rack at the corners.

Props

A doctored rack is used here. The rack has 3 small holes at the corners. Players are free to use their own rack. Players may use chalk cubes to support the balls on top of the rack.

Objective

Shoot the cue ball, causing the indicated ball to go into pocket F. The cue ball will replace that ball under the rack, supporting it.

Special Notes

The rack and the object balls on top may not fall by any means.

Shot 48

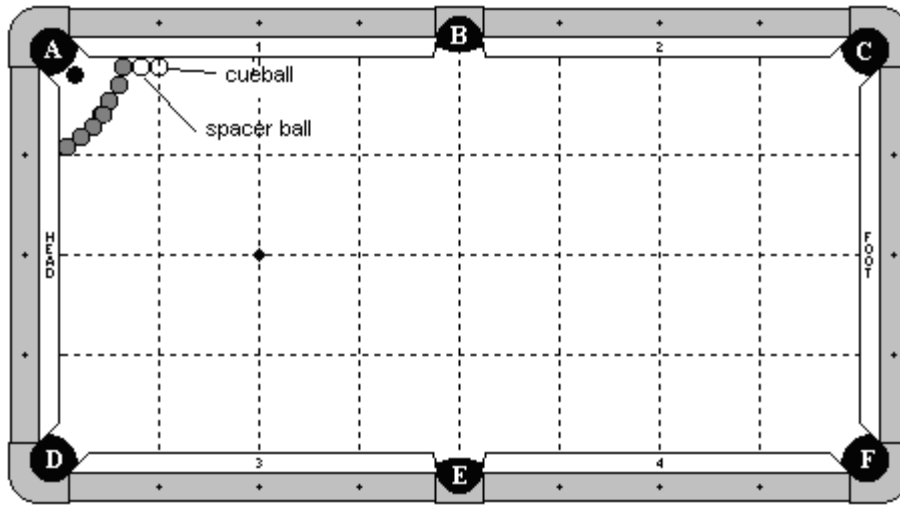

Category

Miscellaneous

Difficulty: 8

Cue Ball

On the 1st diamond, frozen to the rail.

Object Ball

The 8 ball is hanging near pocket A.

Props

A curved row of 7 plastic shot glasses is set beginning 1 ball's width from the cue ball and ending on the head rail. The glasses are a minimum of 2 ¼ inches tall.

Objective

Strike the cue ball into rail 1. It will then squirt over the wall of shot glasses to sink the 8 ball.

Special Notes

The shot glasses may not be touched by any means until after the 8 ball is made. It is okay to push or pinch the cue ball into the rail. The shot does not need to be a legal or a continuous forward motion stroke.

Shot 49

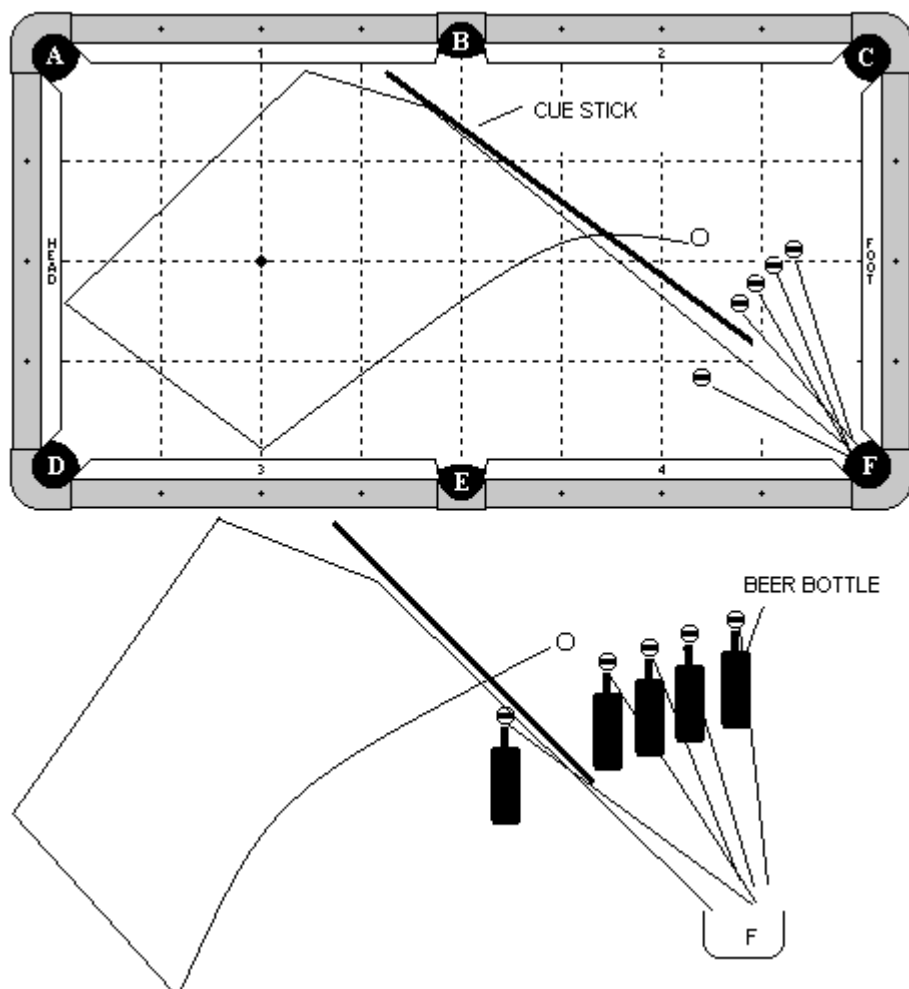

Category

Speed

Difficulty: 9

Cue Ball

In hand

Object Ball

5 balls are placed on 5 bottles

Props

5 bottles are in hand. A cue stick is placed on the table as diagrammed.

Objective

Shoot the cue ball and jump over the cue stick. It will hit 3 rails, touch the stick (optional) and go into pocket F. After hitting the cue ball, shoot all 5 balls into pocket F off of the bottles. The cue ball will be made last.

Special Notes

None

Shot 50

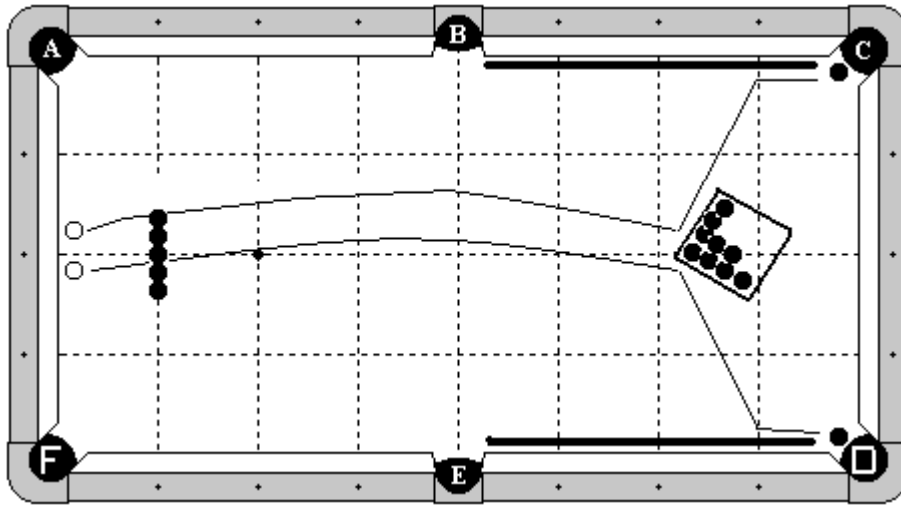

Category

Jump

Difficulty: 9

Cue Ball

2 cue balls are used and are in hand.

Object Ball

5 blocking balls are frozen in line and the center must be on the center line. The line of balls is on the 1st diamond line. Object balls are hanging near pockets C and D.

Props

A regular pool ball box (not a tray) is placed as diagrammed and may be adjusted.

Anything may be placed in the box to give it weight. Two cue sticks are placed along the long rails.

Objective

Using 2 cues, jump both cue balls simultaneously over the blocking balls. Both cue balls must contact the box, then the sticks (contact with the sticks is optional), and then make the hanging object balls.

Special Notes

After the cue balls contact the box, hitting the sticks is optional. The blocking balls may not be touched by any means until after both object balls have been made.

Shot 51

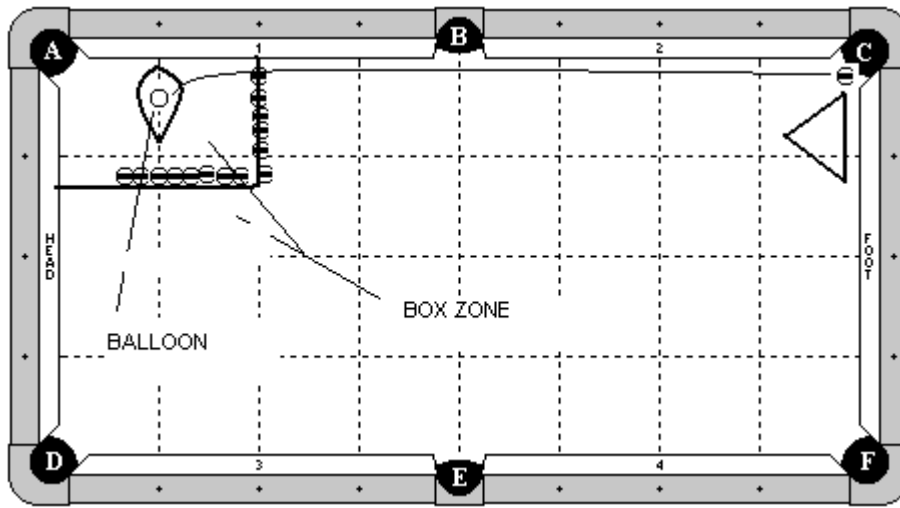

Category

Jump

Difficulty: 9

Cue Ball

Inside the balloon

Object Ball

C ball is hanging near pocket C. The blocking balls are placed as diagrammed. The front line starts frozen to cushion 1 and extends along the 2nd diamond (all frozen to each other) at least 1 diamond off the cushion. Then the line turns towards the head cushion.

Props

The balloon is in hand within the zone created by the object balls. A rack is in hand near pocket C.

Objective

Shoot the cue ball. The balloon will pop. The cue ball will jump over the row of balls and make the object ball.

Special Notes

The balloon is colored but you can see through it. Players are free to use any balloon of any size. The blocking balls may not be touched by the cue ball.

Shot 52

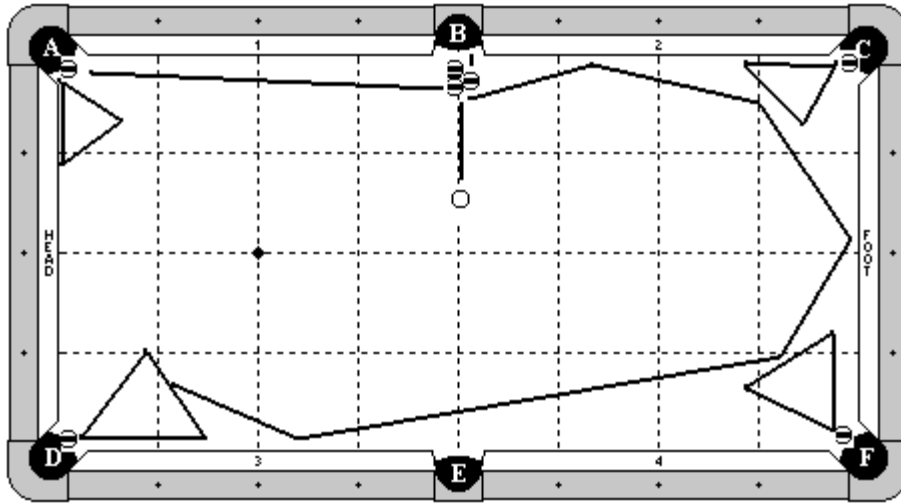

Category

Miscellaneous

Difficulty: 7

Cue Ball

In hand

Object Ball

A,C,F,D balls are hanging near their pockets. The 2 object balls near pocket B are in hand.

Props

4 racks as diagrammed. All are in hand.

Objective

Hit the cue ball into the cluster of 3 balls. The back ball and the ball to the right will go in pocket B. The first ball hit will go into pocket A, also making the hanging ball as well. The cue ball will travel along the indicated path, making the other 3 hanging balls.

Special Notes

The cue ball does not need to contact cushion 3 prior to hitting the rack near pocket D.

Shot 53

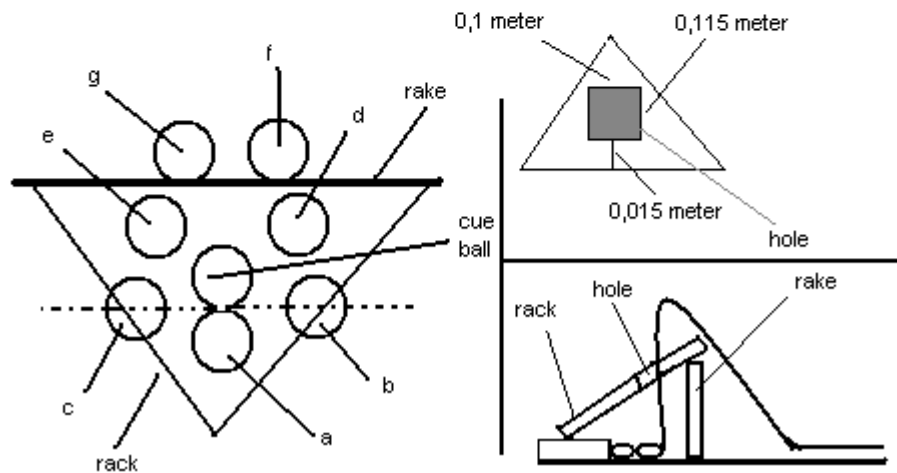
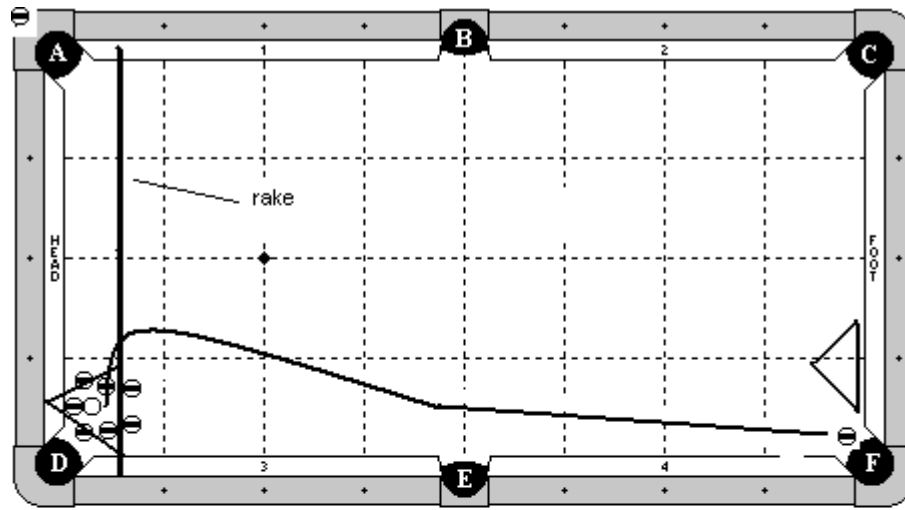

Category

Miscellaneous

Difficulty: 9

Cue Ball

In hand frozen to 'A' ball.

Object Ball

G&F balls are 1 ball's width away from the cue ball. B&C balls are 1 chalk's width away from the cue ball. Balls E&D are in position as diagrammed. Another object ball is hanging near pocket F.

Props

A rack is covered with paper / cardboard. There is a hole in the paper and the exact shape and dimensions are indicated by the diagram. The rack is balanced on the top of the cushion and the bridge, and is adjustable. The bridge is across the table as diagrammed. Another rack is near pocket F as diagrammed.

Objective

Shoot the cue ball into 'A' ball. The cue ball will jump through the hole in the rack and paper, jump over the bridge, and make the ball near pocket F.

Special Notes

After the shot, the rack must stay on the bridge.

Shot 54

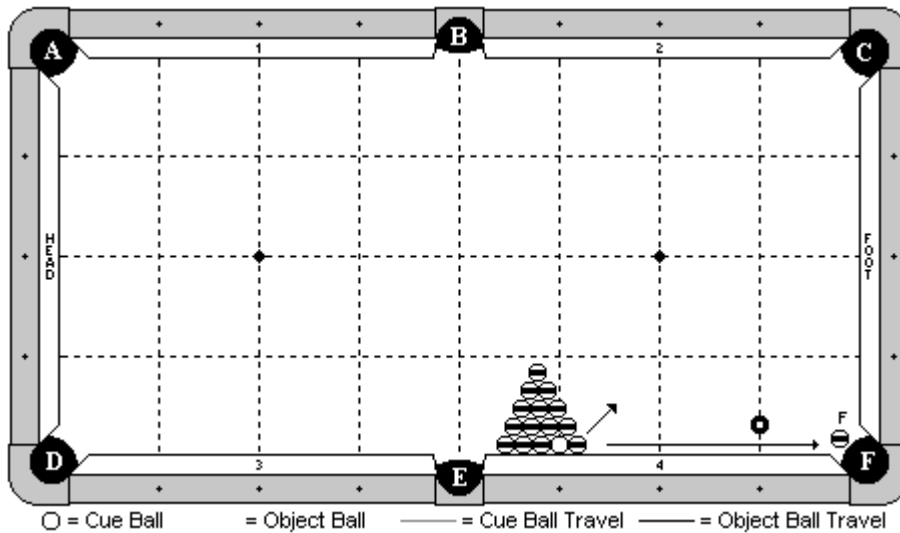

Category

Masse

Difficulty: 8

Cue Ball

Frozen to the cushion at the 3rd diamond.

Object Ball

14 balls are around the cue ball as diagrammed in a standard rack formation. The cue ball is the second ball from the right in the last row. F ball is hanging.

Props

A bottle is on the 1st diamond line and is 1 ball plus 2cm from the cushion.

Objective

Masse the cue ball. The balls will move and the ball to the right of the cue ball will clear, allowing the cue ball to masse down the cushion, go between the bottle and the cushion, and make F ball.

Special Notes

The bottle may not be contacted by any means until after F ball is made.

Shot 55

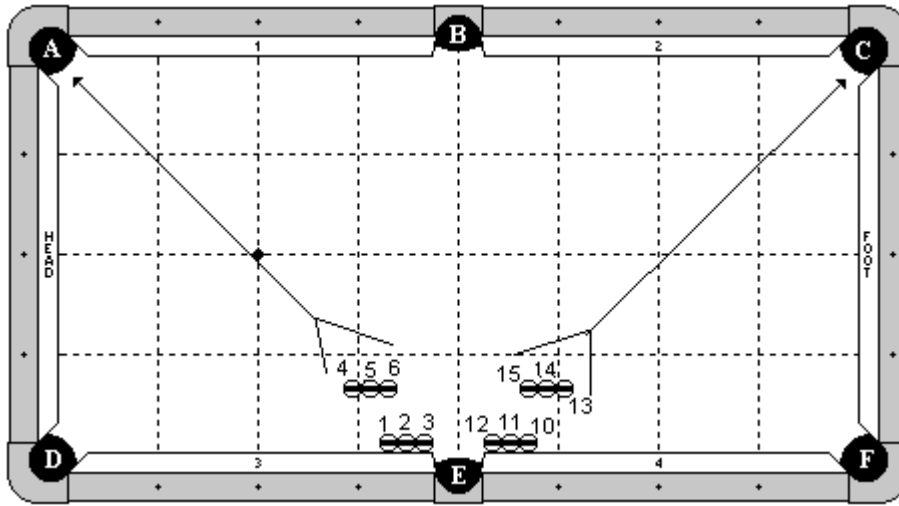

Category

Jump / Speed

Difficulty: 7

Cue Ball

None

Object Ball

Balls 1,2,3 are frozen to each other and to the cushion, with the edge of the 3 ball even with the pocket point. The 6 ball is 2 ball's width from the 1 ball and straight out from the rail. Balls 4 and 5 are frozen in line with the 6 and parallel to the cushion. Balls 10 through 15 form the mirror image.

Props

None

Objective

Jump the 1,2,3 into pocket A. Then shoot the 4,5,6 into pocket A. Then perform the mirror image with the 10 through 15 balls into pocket C.

Special Notes

This is a timed shot. The player has 24 seconds to perform this shot. Each time a ball is hit, no other balls may be disturbed.

Shot 56

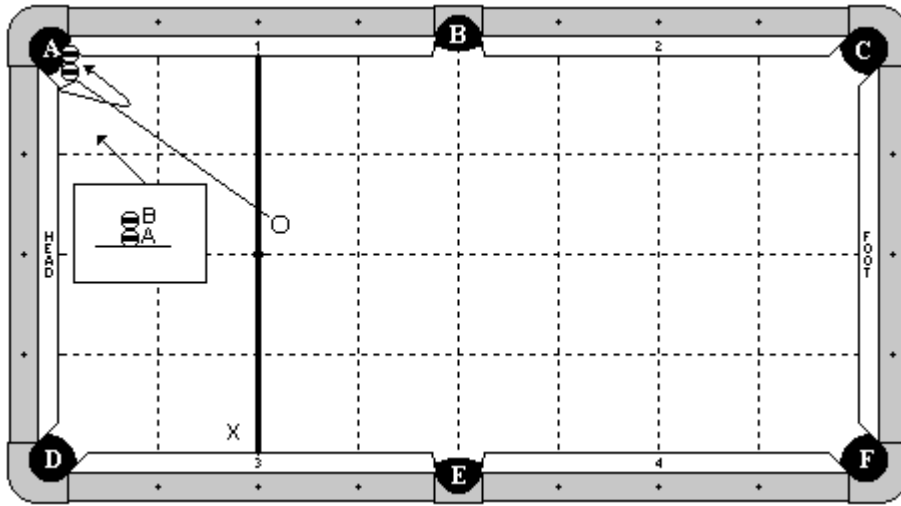

Category

Miscellaneous

Difficulty: 7

Cue Ball

In hand behind X line.

Object Ball

'A' ball is balanced on top of a special stacking ball (Ball B).

Props

A special stacking ball (ball B) is hanging near pocket A.

Objective

Shoot the cue ball into the B ball (stacking ball). Make it in pocket A. The cue ball should rebound off the head cushion and curve as diagrammed, finally making 'A' ball in pocket A.

Special Notes

None

Shot 57

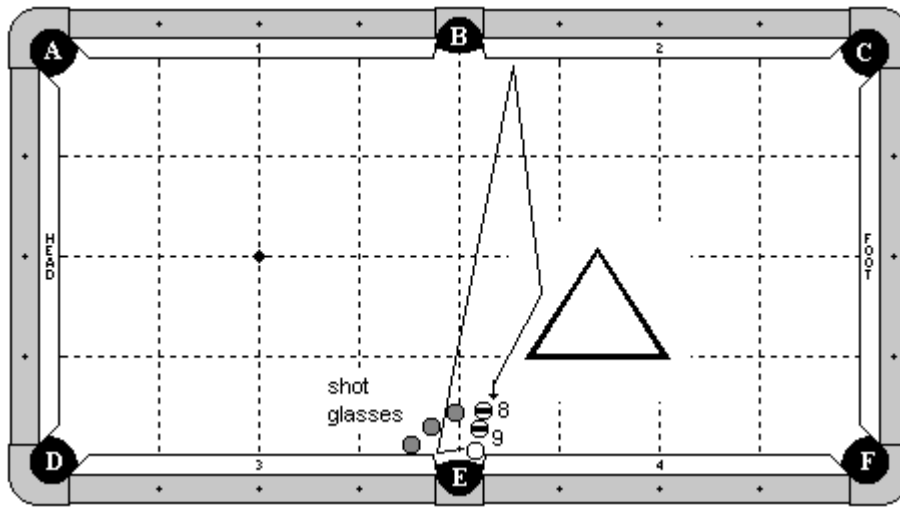

Category

Miscellaneous

Difficulty: 9

Cue Ball

Frozen to the pocket point, with the edge aligned with the pocket cut.

Object Ball

9 ball is not more than $\frac{1}{4}$ inch from the cue ball. The 8 ball is frozen to the 9 ball and is adjustable.

Props

Three plastic shot glasses are in position as diagrammed. The shot glasses are between 2 and 2 $\frac{1}{4}$ inches tall. The first shot glass is frozen to the cushion and 1 inch from the pocket cut. The others are in a curve, spaced equally. A rack is laying on the table and is in hand.

Objective

Shoot the cue ball off the point. It will jump over everything, hit the cushion and bank back. It will then hit the rack (optional), and hit the 8 ball, making the 9 ball in pocket E.

Special Notes

The shot glasses may not be contacted by any means until after the 8 ball is hit by the cue ball. The 8 and 9 balls may not be hit as the cue ball is jumping over them.

Shot 58

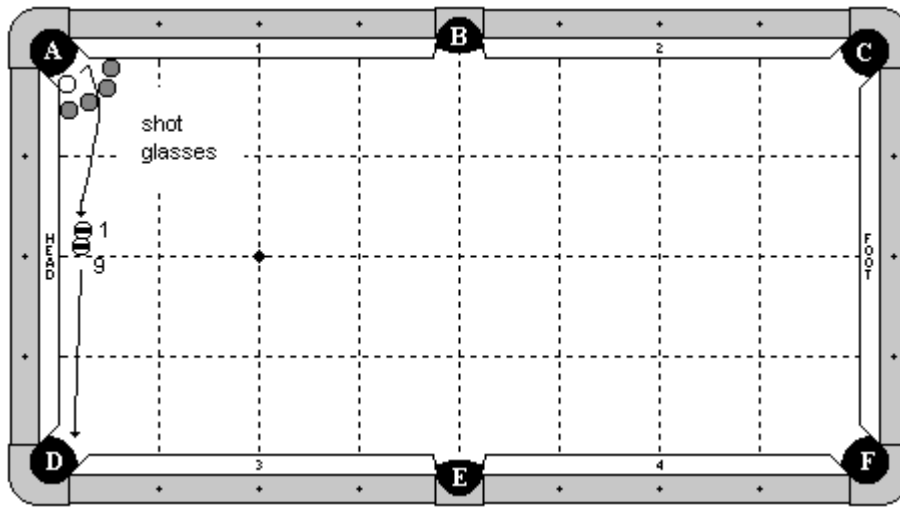

Category

Miscellaneous

Difficulty: 8

Cue Ball

In hand, but must be frozen to the jaw of pocket A.

Object Ball

1 ball is 1 ball's width from the head cushion and in hand anywhere along that cushion.
The 9 ball is frozen to the 1 ball.

Props

4 plastic shot glasses (between 2 and 2 ¼ inches tall) form a semi-circle around the pocket, with the two shot glasses on the ends frozen to the cushion and 1 inch from the point. The other 2 shot glasses are equally spaced.

Objective

Shoot the cue ball into the pocket point, jumping over the shot glasses, and making the 1-9 combination in pocket D.

Special Notes

The cue ball may not contact the shot glasses by any means until after the 9-ball has been made.

Shot 59

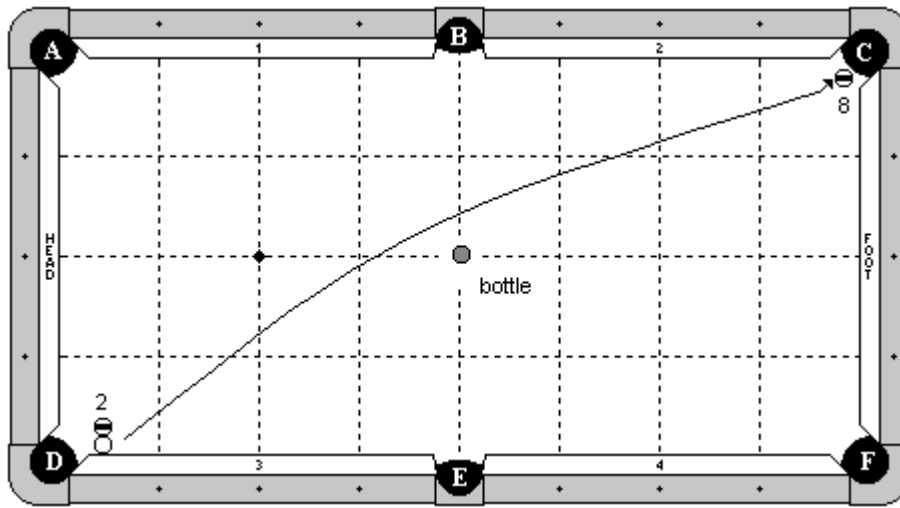

Category

Miscellaneous

Difficulty: 8

Cue Ball

Frozen to cushion 3 and adjustable but it may not be more than 1 diamond away from pocket D.

Object Ball

The 2 ball is frozen to the cue ball and straight out. The 8 ball is hanging near pocket C.

Props

A plastic bottle or glass (minimum diameter 2 inches) is in the exact center of the table.

Objective

Shoot the cue ball into cushion 3, compressing the rail. The cue ball will escape and follow the indicated path around the bottle, making the 8 ball.

Special Notes

The 2 ball and the bottle may not be contacted by any means until after the 8 ball is made.

Shot 60

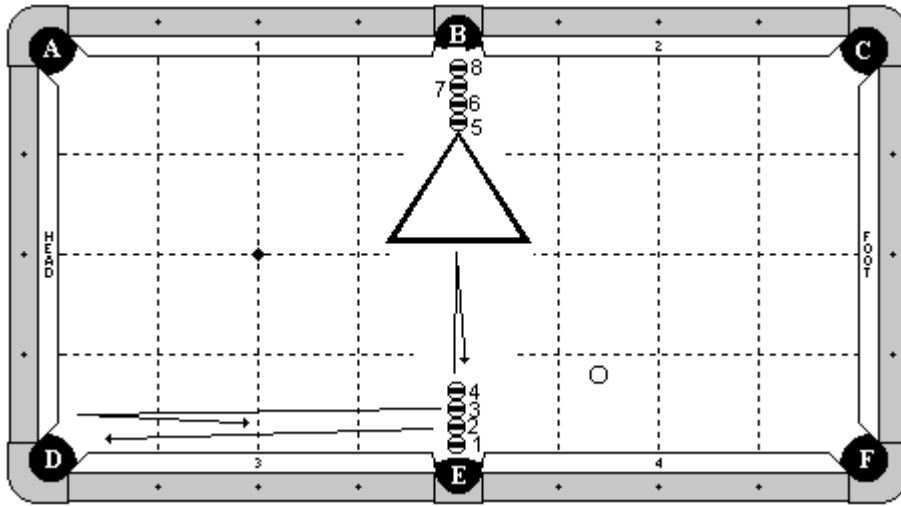

Category

Miscellaneous

Difficulty: 10

Cue Ball

In hand

Object Ball

All balls are arranged as indicated by the diagram, and may be slightly adjusted by the player.

Props

A rack is in hand, frozen to the 5 ball.

Objective

Shoot the cue ball into the first line of balls. The 1 ball will go in pocket E. The 2 ball will go in pocket D. The 3 ball will bank back in pocket F. The 4 ball will hit the rack and rebound back into pocket E. When the 4 ball hits the rack, the 5,6,7,8 balls will all go in pocket B.

Special Notes

None

Shot 61

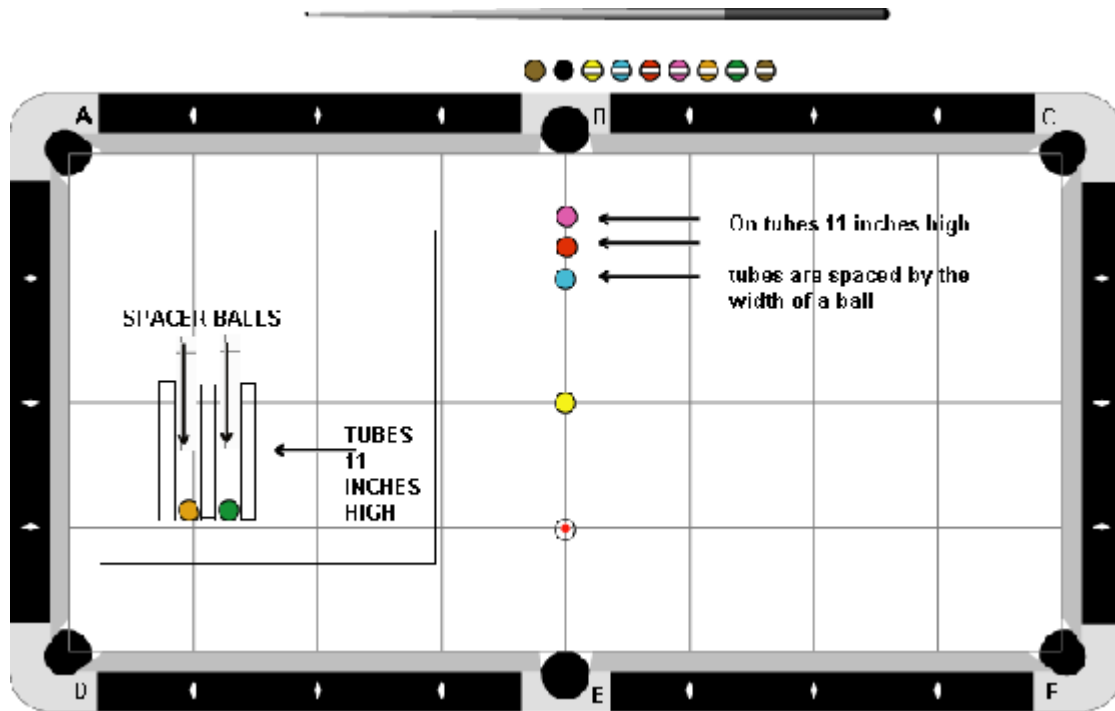

Category

Miscellaneous

Difficulty: 8

Cue Ball

On the center line, 1 diamond from pocket E.

Object Ball

Object ball 1 is on the exact center point of the table. Balls 2,3,4 are also along the center line, but they are propped up by paper tubes about 11 inches tall.

Props

Three paper tubes are supporting 3 object balls. The tube with the 2 ball (closest to the cue ball) is 1 diamond away from pocket B. The other tubes are 1 ball's width apart. The tubes are 8 ½ x 11 inch rolled up paper and taped to hold them in a tube.

Objective

Hit the cue ball into the 1 ball. It will go under the balls into pocket B, knocking the tubes out from under the balls. The 2,3,4 balls will fall and bounce. While they are bouncing, shoot the cue ball under then into pocket B.

Special Notes

The cue ball must be still when re-hit. When the cue ball is hit under the bouncing balls, those balls may not be contacted.

Shot 62

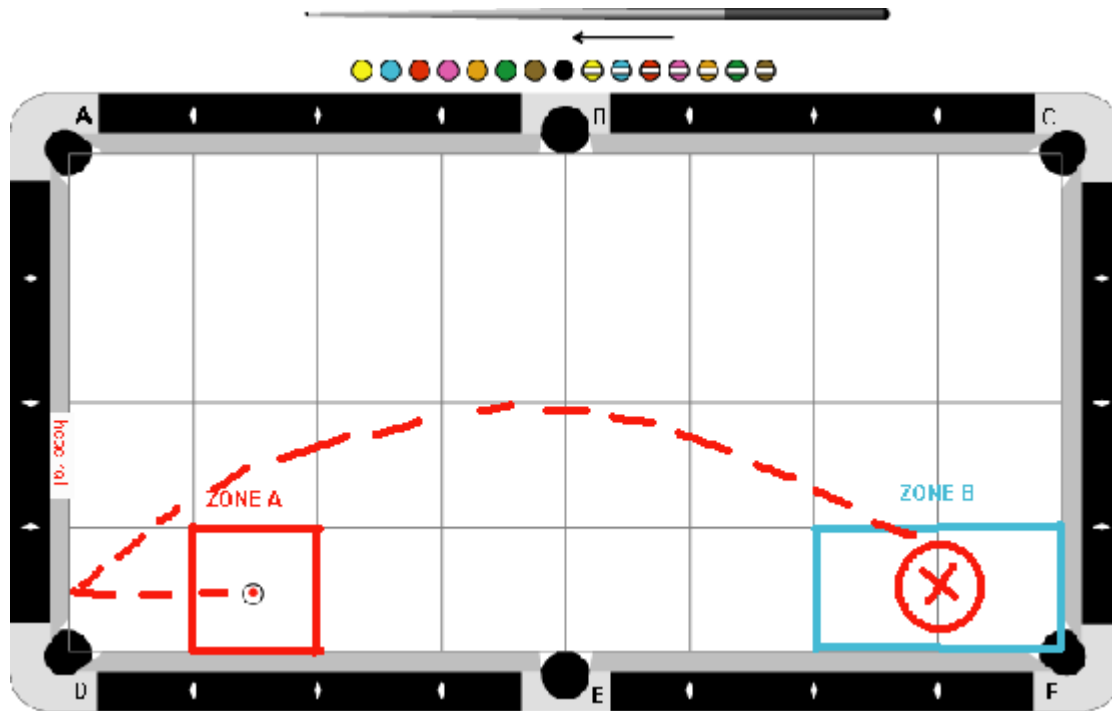

Category

Miscellaneous

Difficulty: 9

Cue Ball

In hand within zone A.

Object Ball

None

Props

A bucket with a diameter of 12 - 14 inches is in hand within zone B. The height is between 9 and 11 inches. The bucket is propped up on one side so it leans towards the cue ball at an angle of about 30 – 45 degrees. Any object (I use a towel) may be used to cause the bucket to lean. Inside the bucket is about 100 poker chips to help absorb the impact of the cue ball.

Objective

Hit the cue ball into the head cushion, causing it to fly back directly into the bucket.

Special Notes

The cue ball must go directly into the bucket. It cannot bounce. The cue ball must remain in the bucket at the conclusion of the shot.

Shot 63

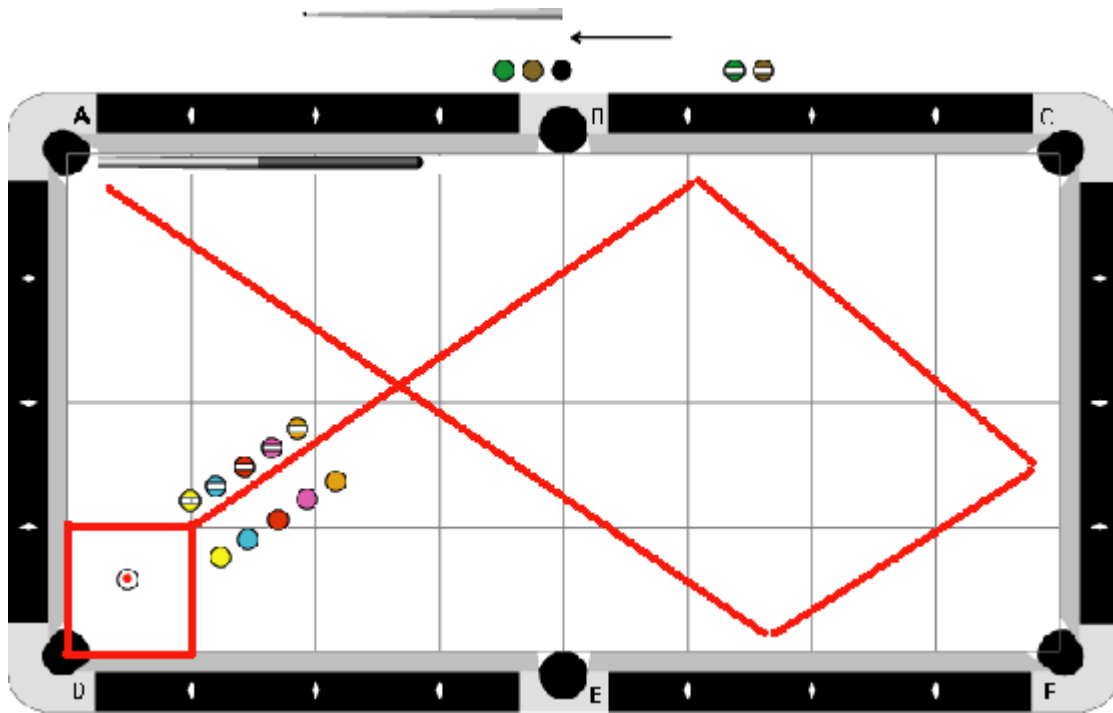

Category

Jump / Speed

Difficulty: 10

Cue Ball

In hand within the indicated zone.

Object Ball

2 rows of 5 balls as diagrammed. A gap of 2 ball's width is between the rows. The stripe balls as diagrammed must be directly in the line from the corresponding solid ball and pocket A.

Props

A cue stick butt is frozen to the cushion to help guide the cue ball into the pocket.

Objective

Strike the cue ball 3 cushions as diagrammed. As the cue ball in rolling, jump the balls in numerical order (left to right) into pocket A. The cue ball will be the last ball to go in pocket A.

Special Notes

The blocking balls may not be touched by any means. The jumping object balls may not touch the cue stick.

Shot 64

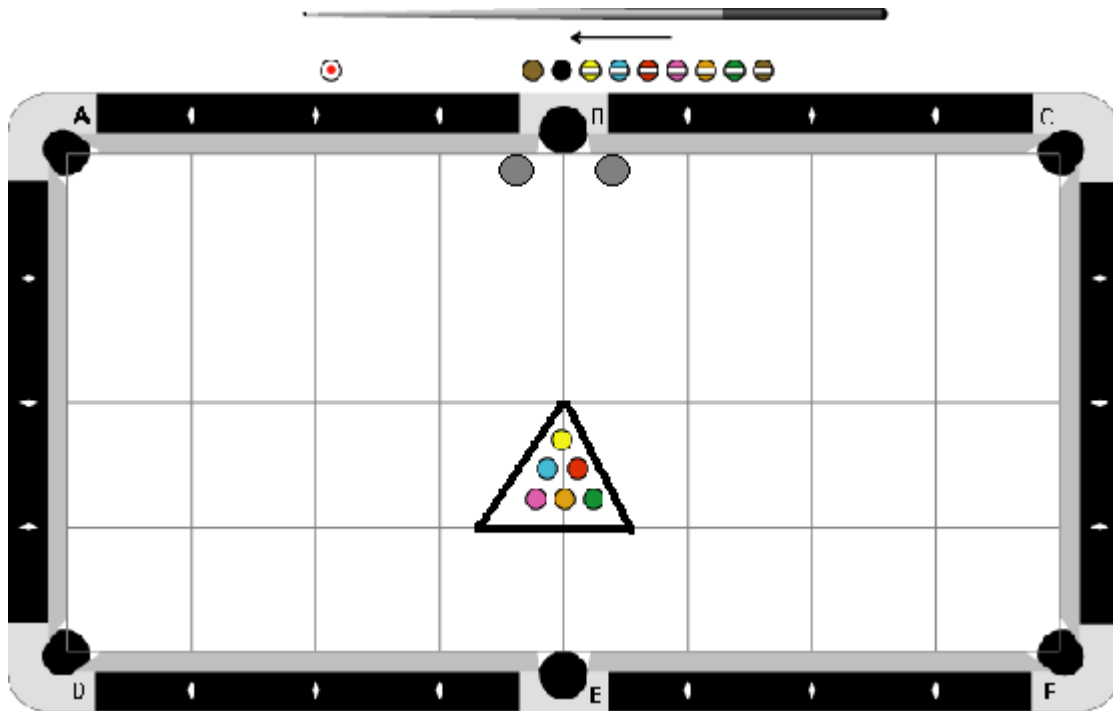

Category

1-handed jump / Speed

Difficulty: 9

Cue Ball

None

Object Ball

6 balls are in hand within a rack.

Props

The rack is in hand, but centered on the center line of the table. The point of the rack must be behind the long center line. 2 plastic champagne glasses are frozen to the cushions next to pocket B, with the edge of each glass even with the pocket point. There is an object ball inside each glass.

Objective

Jump all 6 balls out of the rack and into pocket B. The shot must be performed 1 handed

Special Notes

The player must perform this shot in 18 seconds. The rack may not be touched by any means. The champagne glasses may not be touched by any means.

Shot 65

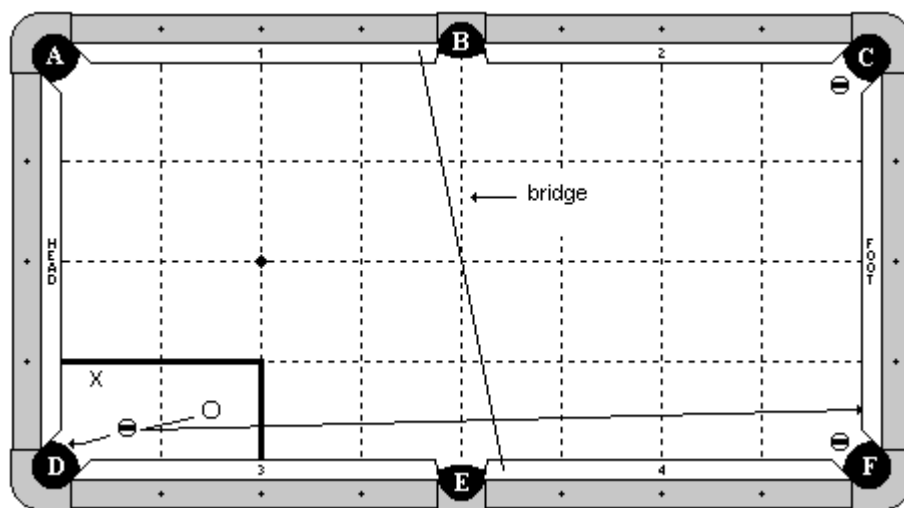

Category

Miscellaneous

Difficulty: 8

Cue Ball

In hand within the indicated zone.

Object Ball

In hand within the indicated zone.

Props

A bridge is on the rail tops across the table as diagrammed. Two balls are placed in front of pockets C and F.

Objective

The cue stick must pass under the bridge, and without using anything other than our hands, stretch on the table and hit the cue ball to pocket the object ball in pocket D. The cue ball will then draw back and either hit the foot cushion, or pocket one of the object balls in either pocket C or F.

Special Notes

The cue ball may contact one of the long cushions on its way back down the table. The player must stand behind the foot rail when shooting this shot. No accessories may be added to the cue stick. A normal length cue stick must be used.

Shot 66

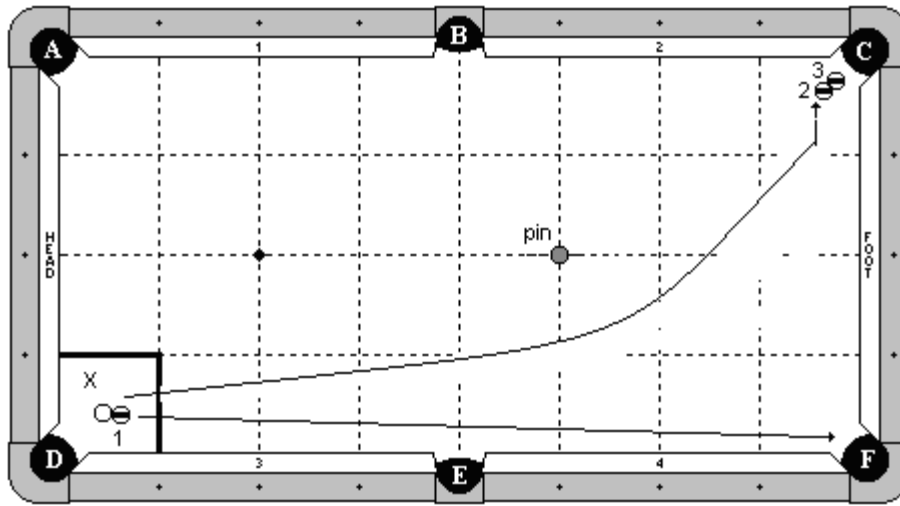

Category

Masse

Difficulty: 8

Cue Ball

In hand within zone X

Object Ball

1 ball frozen to the cue ball, in hand within zone X. The 2-3 combination is near pocket C.

Props

A pin or bottle is placed on the diamond intersection line indicated by the diagram.

Objective

Shoot the cue ball, causing the 1 ball to go into pocket F. The cue ball will travel the indicated path, making the 2-3 combination.

Special Notes

The cue ball may not contact the long rail (cushions 3 or 4) until the 3 ball is made. The cue ball may contact an extra cushion near pocket C. The pin or bottle may not be contacted by any means until after all balls have been made.

Shot 67

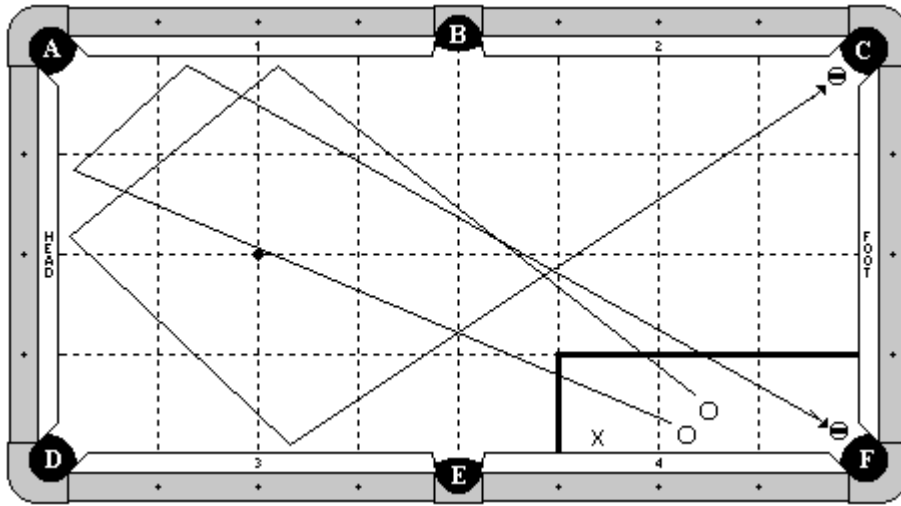

Category

Miscellaneous

Difficulty: 9

Cue Ball

2 cue balls are used and both are in hand within zone X

Object Ball

2 object balls are hanging near pockets C and F.

Props

None

Objective

Using two cues, shoot both cue balls at the same time. The cue balls will travel along the diagrammed path, making both object balls.

Special Notes

Both cue balls may contact an extra rail near pockets C and F.

Shot 68

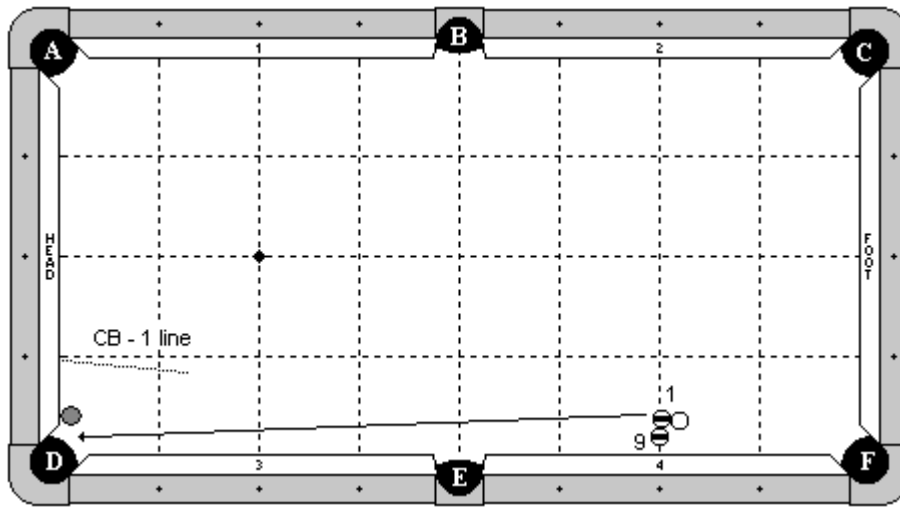

Category

Miscellaneous

Difficulty: 7

Cue Ball

Frozen to 1 ball. The cue ball and 1 ball form a line towards the 1st diamond as indicated by the diagram.

Object Ball

The 9 ball is on the 2nd diamond line, no more than 1 ball's width from the cushion. The 1 ball is frozen to the 9 ball and may be adjusted, but it must remain in line with the cue ball and the 1st diamond.

Props

A special stacking ball is placed frozen to the head cushion with its edge aligned with the pocket point. An object ball is on top of the stacking ball.

Objective

Shoot the cue ball to force the 1 ball around the 9 ball, into pocket D. The 9 ball may not move from its original spot.

Special Notes

The 9 ball will be tapped into place prior to the shot. In order for the shot to be successful, the 9 ball may rock, but it must settle back into its original spot. The referee will be the judge as to whether the 9 ball is in its original spot. The stacking ball and the object ball on top of it may not be contacted by any means by the 1 ball.

Shot 69

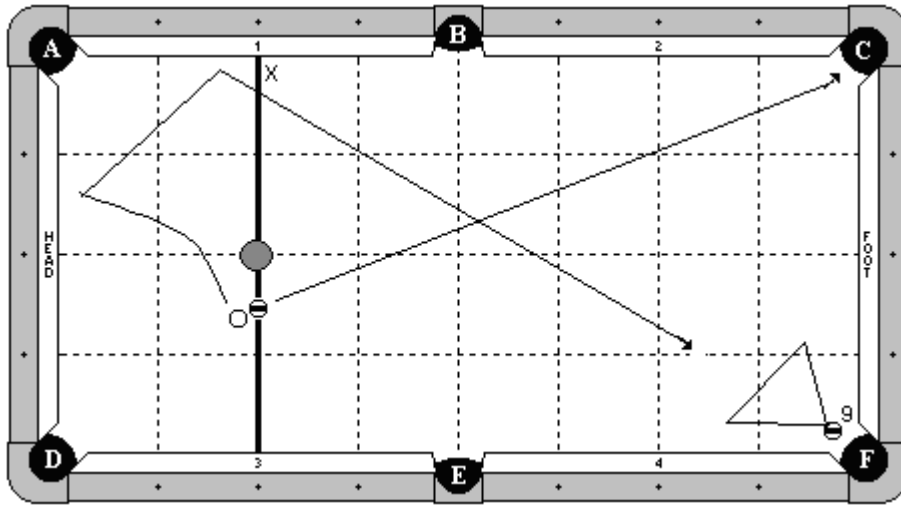

Category

Stroke

Difficulty: 9

Cue Ball

In hand behind X line, no more than 3mm from the object ball.

Object Ball

1 ball is on the X line in hand, to the right of the bottle. The 9-ball is near pocket F.

Props

A bottle is on the head spot. A rack is frozen to the 9-ball and adjustable.

Objective

Shoot the cue ball into the 1 ball, causing it to go into pocket C. The cue ball will travel the indicated path 2 cushions, hit the rack, causing the 9-ball to go into pocket F.

Special Notes

The cue ball will travel between the bottle and the head cushion. The bottle may not be touched by any means until after all balls have been made. The cue ball may hit an extra cushion near pocket F.

Shot 70

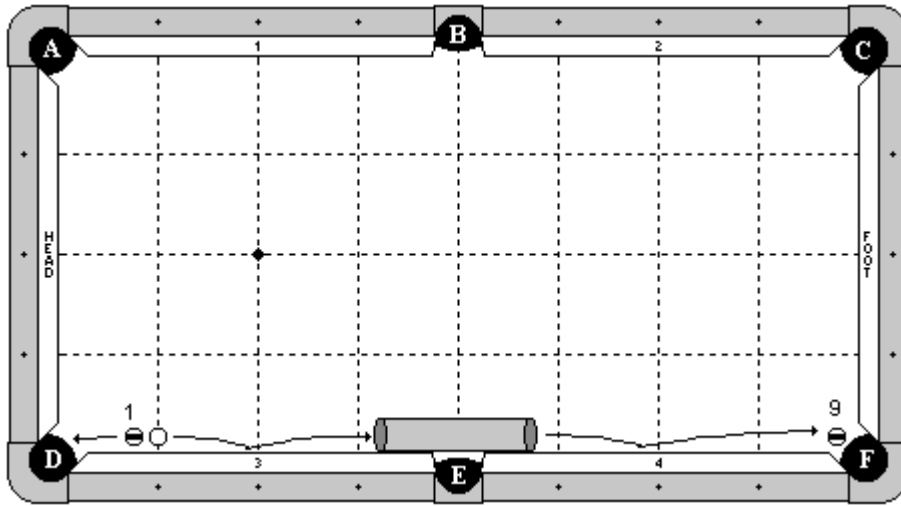

Category

Masse

Difficulty: 8

Cue Ball

Along the 1st diamond line, close to cushion 3.

Object Ball

1 ball is at least ½ inch from the cue ball. The 9 ball is near pocket F.

Props

A tube is on the table, frozen to the long rail. The tube is about 4 inches in diameter and about 10 inches long. It is centered around pocket E.

Objective

Masse the cue ball to make the 1 ball in pocket D. The cue ball will come back and through the tube, making the 9 ball in pocket F.

Special Notes

The tube must be placed on the table with nothing else holding it in place.

Shot 71

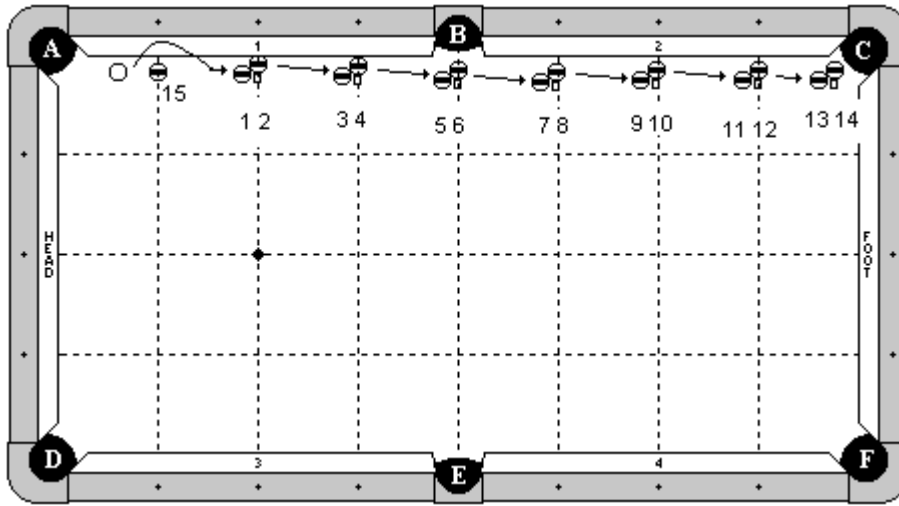

Category

Jump

Difficulty: 6

Cue Ball

2 chalk's width from the 15 ball.

Object Ball

Balls 2,4,6,8,10,12,14 are on chucks. Balls 1,3,5,7,9,11,13 are on the table, frozen to the corresponding ball on the chuck. The 15 ball is on the 1st diamond line and directly between the cue ball and the 1 ball.

Props

Chucks as mentioned above.

Objective

Jump the cue ball over the 15 ball into the 1 ball. This will start a chain reaction. All of the balls will be hit in order as diagrammed, eventually causing the 14 ball to go into pocket C.

Special Notes

The 15 ball may not be touched by any means, until after the cue ball contacts the 1 ball.

Shot 72

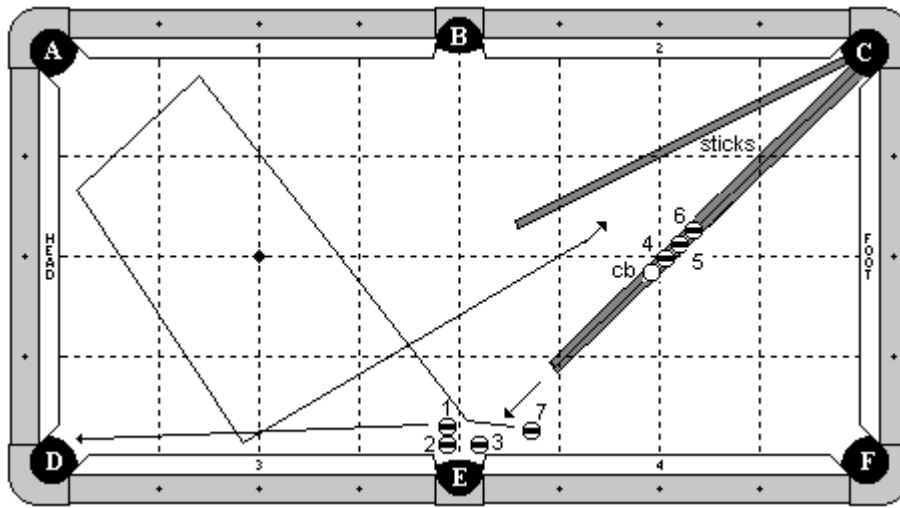

Category

Miscellaneous

Difficulty: 8

Cue Ball

On the sticks, adjustable.

Object Ball

The 4,5,6 balls are on the sticks in order. The 1,2,3 balls are near pocket E as diagrammed. The 7 ball is in hand.

Props

Three sticks are in the classic 'railroad' formation as diagrammed. A small piece of paper or anything is placed under the cue ball to hold the balls in place. Clips may be optionally used to hold the sticks together.

Objective

Shoot the 7 ball into the 1 ball. The 1 ball will go in pocket D, and the 2 ball will go in pocket E. The 7 ball will go three rails, up and down the sticks, and contacting the 6 ball. The cue ball will make the 3 ball and get out of the way. The 4,5,6,7 will all go into pocket E in order.

Special Notes

The cue ball may not scratch. The cue ball may not be contacted by the 4,5,6,7 as they roll down the sticks and into pocket E. The cue ball and balls 4,5,6 must remain on the sticks in their original position until the 7 ball comes around and hits the 6 ball. A special train whistle will be used for sound effects, but the players have the option if they want to use it.

Shot 73

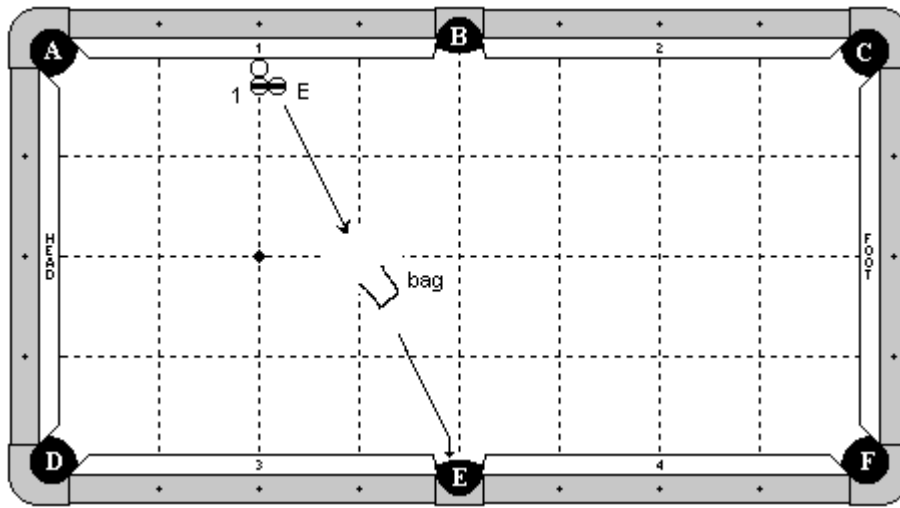

Category

Miscellaneous

Difficulty: 7

Cue Ball

Frozen to cushion 1, on the head string.

Object Ball

1 ball is frozen to the cue ball, on the head string. E ball is frozen to the 1 ball, and 1 ball's width from cushion 1.

Props

A paper bag is in hand between the E ball and pocket E. The paper bag may not have an opening more than 4 inches wide. The bag must be a minimum of 5 ½ inches long. The bag may not be more than 2 diamonds away from pocket E.

Objective

Shoot the cue ball into the cushion, compressing the rail. Kick E ball through the bag, flipping it over, and into pocket E.

Special Notes

The 1 ball may not move by any means until after E ball is made. At the conclusion of the shot, the bag may not lean over the pocket cut, and may not be leaning against the cushion.

Shot 74

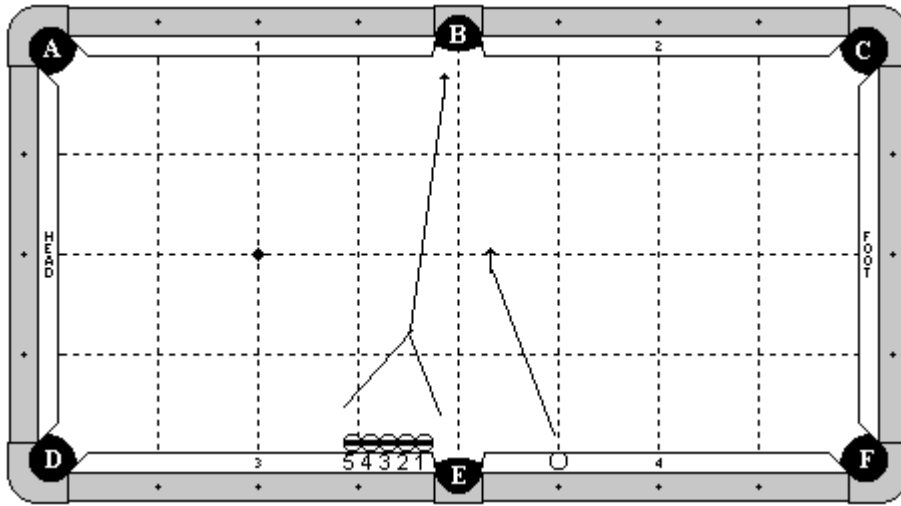

Category

Speed

Difficulty: 9

Cue Ball

On the rail top, centered at the 3rd diamond.

Object Ball

Balls 1 through 5 are frozen to each other and to the cushion in line. The 1 ball has its edge even with the pocket point.

Props

None

Objective

Shoot the cue ball off the rail towards pocket B. Shoot the 1 through 5 balls in numerical order into pocket B. The cue ball will be the last ball to go into pocket B.

Special Notes

None

Shot 75

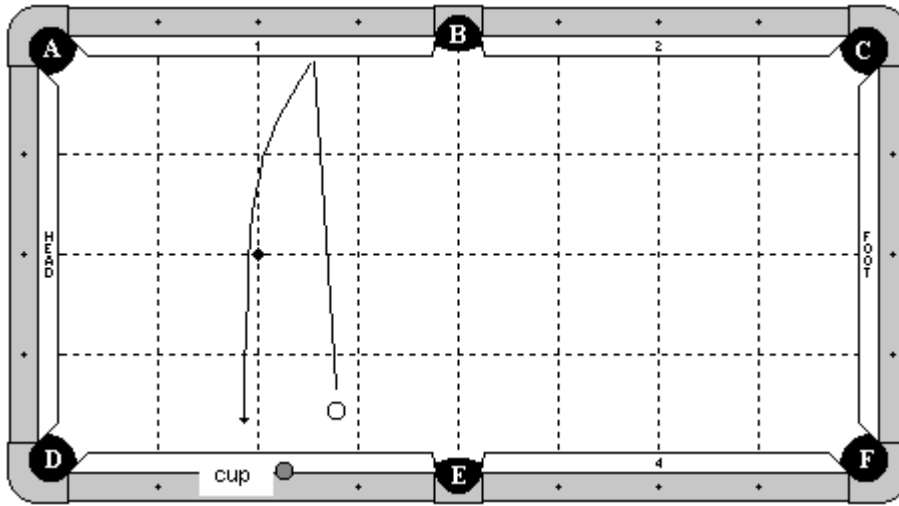

Category

Miscellaneous

Difficulty: 8

Cue Ball

In hand

Object Ball

None

Props

A 12 ounce plastic cup is in hand on the rail top. The cup is 4 ½ inches tall, 3 ¼ inches diameter at the opening and 2 ½ inches diameter at the base. Players are free to use their own cup provided that they do not exceed the measurements given, and the cup must be plastic (no Styrofoam).

Objective

Shoot the cue ball into the opposite cushion, making it jump back in the air. Pickup the cup and catch the cue ball in the cup. Player will then roll the cue ball out of the cup into a pocket of their choice.

Special Notes

None

Shot 76

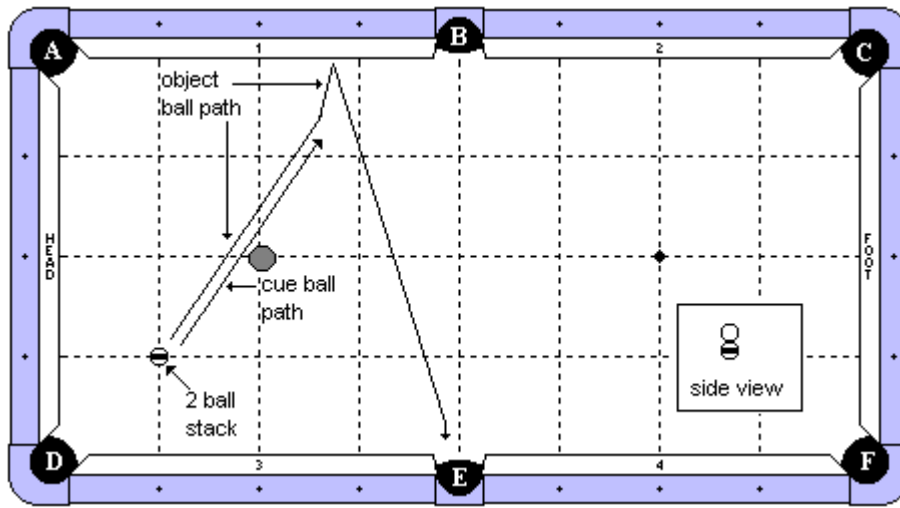

Category

Wing

Difficulty: 8

Cue Ball

Balanced on top of a stacking ball as diagrammed.

Object Ball

None

Props

A special stacking ball is placed at the 1-1 diamond intersection line as diagrammed. A plastic champagne glass is on the head spot with an object ball inside of it.

Objective

Shoot the stacking ball out from under the cue ball, causing the cue ball to fall in place. Shoot the cue ball into the rolling stacking ball, causing it to bank as diagrammed into pocket E.

Special Notes

The stacking ball must be rolling when the cue ball hits it. The cue ball must hit the stacking ball before it hits any cushion. The champagne glass may not be contacted by any means until after the stacking ball is made.

Shot 77

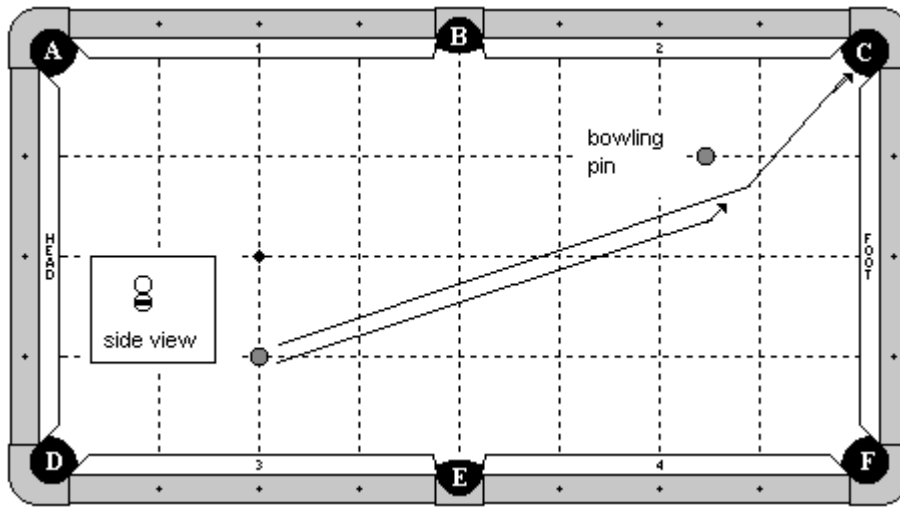

Category

Wing

Difficulty: 7

Cue Ball

Balanced on top of a stacking ball as diagrammed.

Object Ball

None

Props

A special stacking ball is on the 1-2 diamond intersection line as diagrammed. A pin or bottle is placed 1 diamond from cushion 2 and 1 1/2 diamonds from the foot cushion.

Objective

Shoot the stacking ball out from under the cue ball along the indicated path. The cue ball will fall. Hit the cue ball into the rolling stacking ball, making a wing shot into pocket C.

Special Notes

The stacking ball must be moving when hit by the cue ball. The cue ball must contact the stacking ball before it hits the foot cushion. The pin or bottle may be hit, but it may not fall over until all balls come to rest.

Shot 78

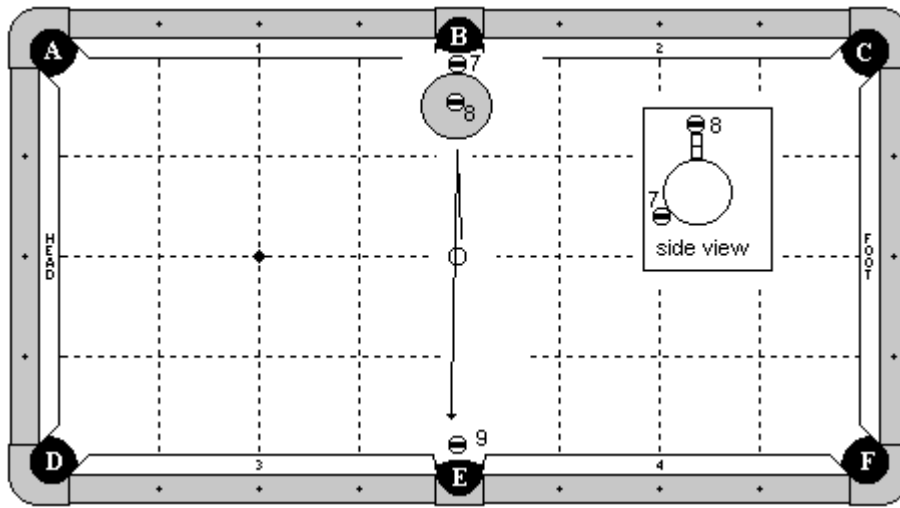

Category

Miscellaneous

Difficulty: 7

Cue Ball

On the center point of the table.

Object Ball

7 ball has the edge even with the pocket cut. 8 ball is balanced on 2 chinks on top of the large Aramith ball. The 9 ball is hanging near pocket E.

Props

A large Aramith cue ball (6 inches diameter) is frozen to the 7 ball. Two chinks are balanced on top of this large ball (wells reversed), with the 8 ball on top of them.

Objective

Shoot the cue ball into the large Aramith ball. The normal cue ball will bounce back and make the 9 ball into pocket E. The impact will cause the 7 ball to go into pocket B. In addition, the 8 ball will fall off the prop and go into pocket B. At least one of the two chinks must also fall into pocket B.

Special Notes

None

Shot 79

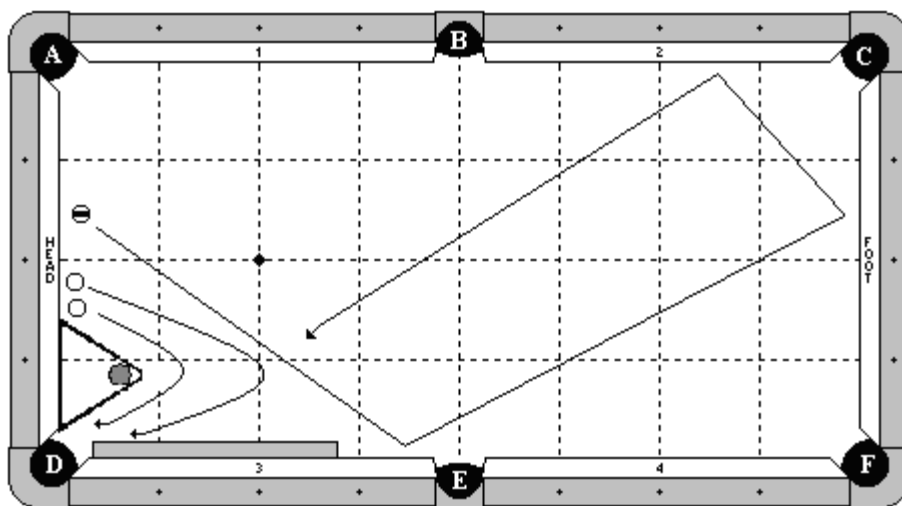

Category

Masse / Speed

Difficulty: 9

Cue Ball

2 cue balls are in hand between the center diamond and the rack (measured by the edge of the ball). The cue balls may not be more than 1 ball's width off the rail.

Object Ball

An object ball is in hand along the 1 ½ diamond line.

Props

A rack is placed frozen to the head rail. A plastic champagne glass (with an object ball in it) is placed frozen to the top point of the rack (inside the rack). A cue stick butt is along cushion 3 and frozen to it.

Objective

Shoot the object ball 3 rails as diagrammed, and into pocket D. Before the object ball goes into pocket D, masse both cue balls, one at a time, around the rack and into pocket D.

Special Notes

All balls may use the rack or stick as a guide to go into pocket D. The balls may contact each other. The object ball must be the last ball to go into the pocket. The champagne glass may not be contacted by any ball. The player may not interfere with any of the props once the shot has started.

Shot 80

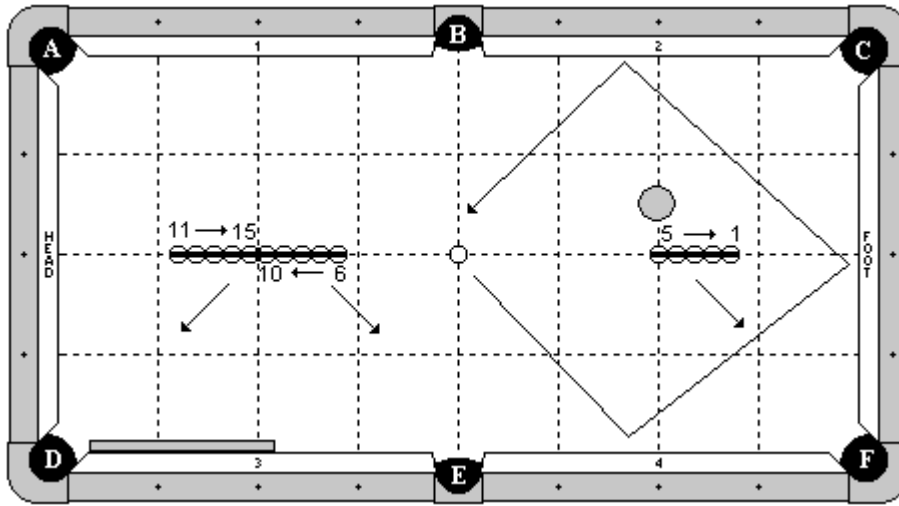

Category

Juggling / Speed

Difficulty: 9

Cue Ball

On the center spot.

Object Ball

All 15 balls are lined up along the center line as diagrammed. The 5 ball is on the foot spot. The 10 and 15 balls contact each other on the head spot. All balls are straight and frozen to each other. The balls should be placed in the numerical order diagrammed.

Props

A circular object is placed 1 ball's width from the 5 ball, along the foot string. It is 3 ½ inches in diameter. Players are free to use any object provided it is not smaller than the one described. I use an 'Easy' button from Staples. A cue stick butt is frozen along the cushion near pocket D.

Objective

Shoot the cue ball 3 rails around the circular object. While the cue ball is moving, shoot the 1-5 into pocket F in numerical order. Re-hit the moving cue ball, and then shoot the 6-10 into pocket E in numerical order. Re-hit the moving cue ball, and then shoot the 11-15 into pocket D in numerical order. The cue ball will go last into pocket D.

Special Notes

The 1-5 balls must be shot free-handed (air bridge). Your hand may not touch the table nor the circular object. The 6-10 must be shot with the bridge hand on the table. The 11-15 must be shot with the opposite hand (lefty in most cases). All hits on the cue ball must be made while in motion. If the cue ball slows so much that it is hard to tell whether it is still moving, the referee will call the shot no good. In all cases, the cue ball must go around the circular object. The circular object may not be contacted by any means. When shooting an object ball, no other object ball may be disturbed by any means.

Shot 81

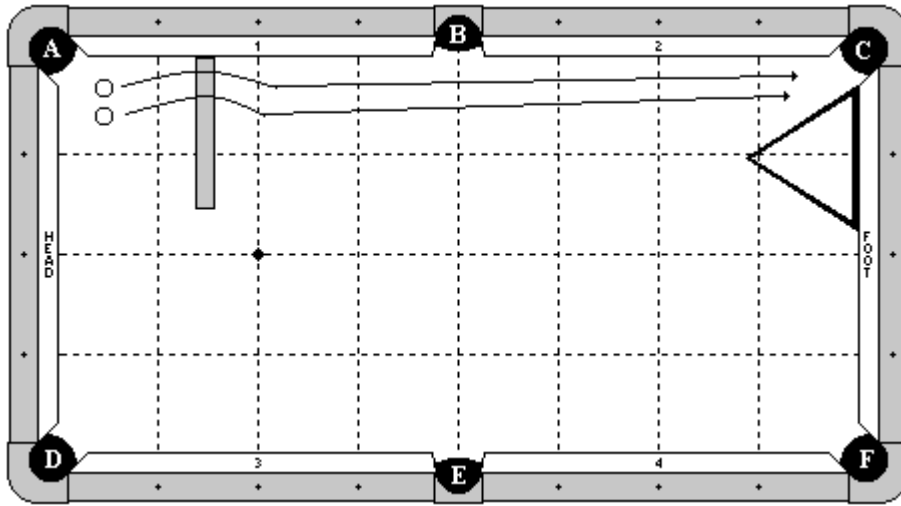

Category

1-handed jump

Difficulty: 9

Cue Ball

None

Object Ball

The 8 and 9 balls are along the $\frac{1}{2}$ diamond line and may be adjusted along this line. The right edge of the object balls may not go beyond the right edge of the domino line. The balls may not be more than 1 chalk's width apart.

Props

A line of 6 dominos are placed along the $1\frac{1}{2}$ diamond line. They are straight and frozen in line, with the first one frozen to the cushion. The dominos are standing in their short position, so the height of the barrier is $1\frac{1}{8}$ inches tall. Players are free to use any object, provided it is no shorter than the dominos. A rack is placed near pocket C and frozen to the foot cushion. Any object(s) may be used as a weight to place inside or against the rack to keep it in place, provided those objects do not interfere with the shot.

Objective

With 2 jump cues, jump both balls 1 handed, simultaneously, over the dominos and into pocket C.

Special Notes

The 2 balls must be jumped at the same time. There may not be a noticeable pause between the two jump shots. The player must hold 1 jump cue in each hand and attempt to jump both balls at approximately the same time. One jump will be one-handed lefty and one will be one-handed righty. The dominos may not be contacted by any means.

Shot 82

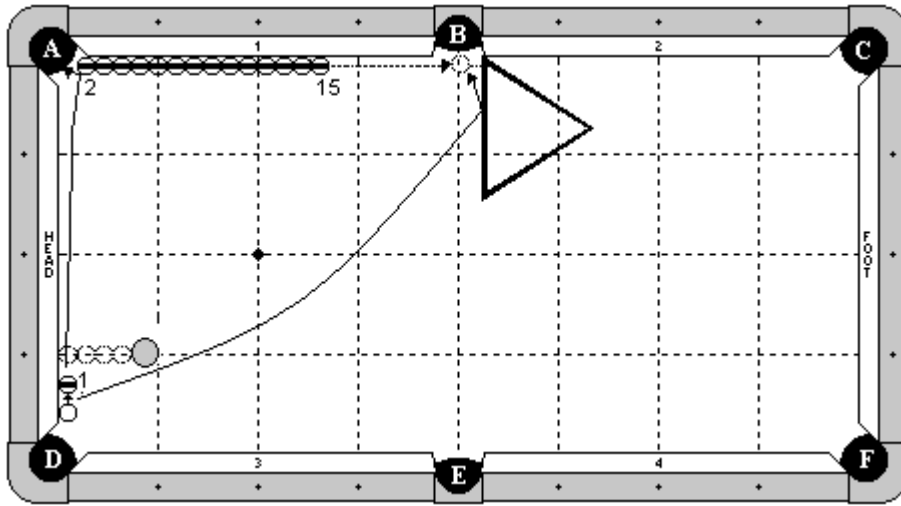

Category

Stroke

Difficulty: 8

Cue Ball

Frozen to the cushion, with the edge even with the pocket point.

Object Ball

1 ball is in hand frozen to the cushion. The 2-15 are frozen to the cushion and to each other, in line along the cushion. The player is free to adjust this line up or down the cushion.

Props

A circular prop (3 ½ inches diameter) is placed 4 balls out from the rail at the 1st diamond. A rack is placed with its point wedged into the side pocket and may be adjusted. The rack edge facing the balls must be perpendicular to the cushion. The circular prop is a Staples 'Easy' button, but players may use anything that is at least 3 ½ inches diameter.

Objective

Shoot the cue ball into the 1 ball. The 1 ball will go into pocket A, hitting the 2 ball along the way. This will cause the 15 ball to roll up and hit the rack and sit in front of the pocket. The cue ball will spin around the object, hit the rack (optional) and make the 15 ball in the side pocket.

Special Notes

The 15 ball must be made by the cue ball. It may not contact the rack and go in by itself. The circular object may not be contacted by any means by the cue ball until after the 15 ball is made.

Shot 83

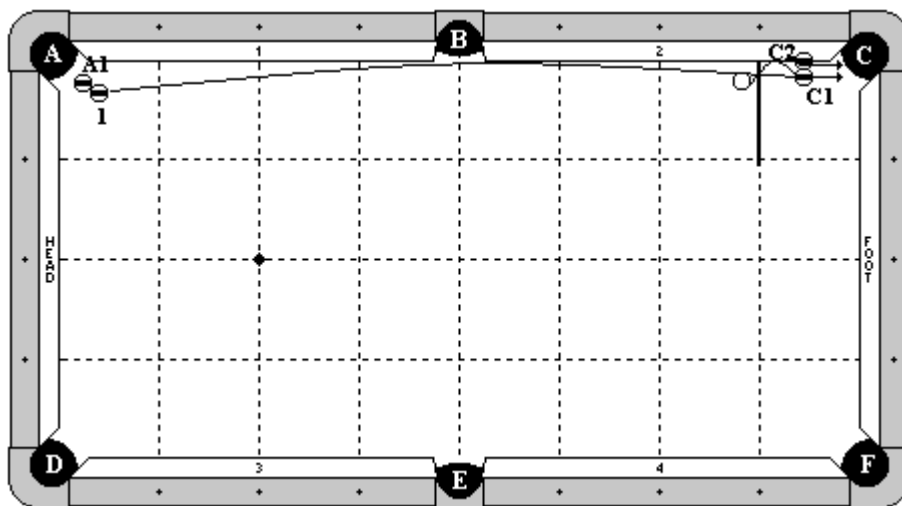

Category

Miscellaneous

Difficulty: 8

Cue Ball

In hand behind the 1st diamond.

Object Ball

C2 ball is balanced on a special stacking ball. Balls A1 and 1 form a combination near pocket A.

Props

C1 ball is a special stacking ball, and is in hand along the ½ diamond line.

Objective

Hit the cue ball into the C1 ball, causing C2 ball to fall. C1 goes into pocket C first. As C2 ball falls, the cue ball will hit it into pocket C (this ball will go second). The cue ball will then draw back to make the combination near pocket A.

Special Notes

None

Shot 84

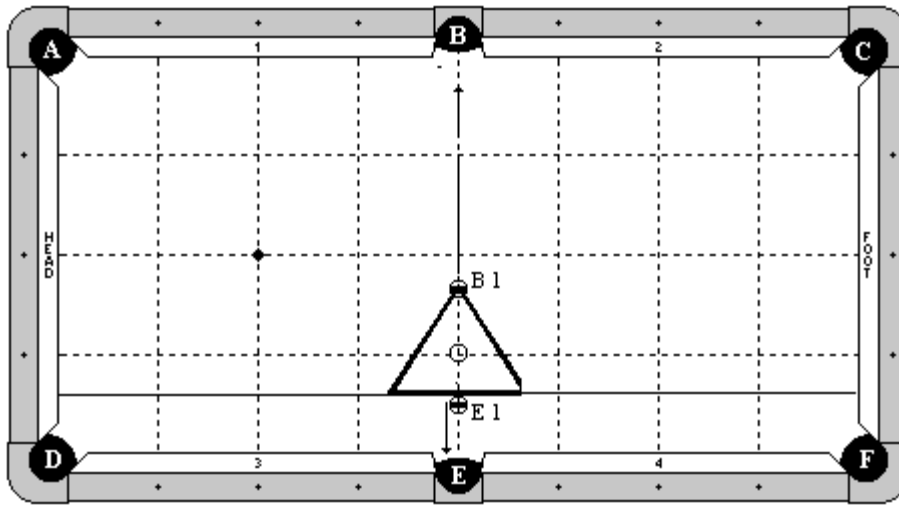

Category

Miscellaneous

Difficulty: 7

Cue Ball

In hand, inside a rack.

Object Ball

E1 ball is frozen anywhere along the back edge of the rack as diagrammed.

Props

B1 ball is a special stacking ball, and it is propped up on the point of the rack. The rack is centered along the center line of the table. The back edge of the rack is on the $\frac{1}{2}$ diamond line as indicated.

Objective

Using a free-hand (air) bridge, hit the cue ball into B1 ball, making it in pocket B. The cue ball stays within the rack and draws back to hit the rack and make E1 ball in pocket E.

Special Notes

The cue stick may not touch E1 ball at anytime during the shot. You may optionally place a piece of cloth in the side pocket to absorb B1 ball's impact in the side pocket to help it not bounce out.

Shot 85

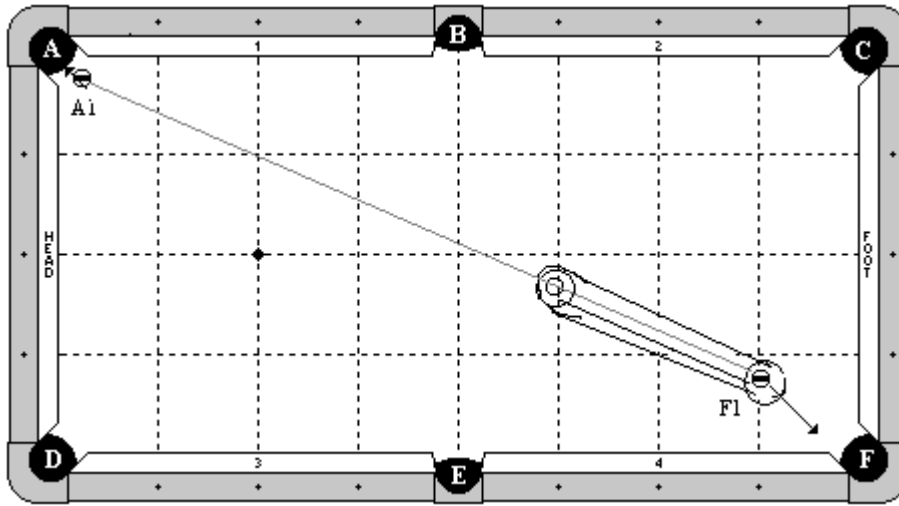

Category

Miscellaneous

Difficulty: 7

Cue Ball

Inside the tube. The entire cue ball (edge) must be within the tube.

Object Ball

F1 ball is in the tube (entire ball must be inside). A1 ball is hanging near pocket A.

Props

A tube is on the table, with the edge even or within the 1x1 diamond zone near pocket F. The tube is about 33 inches long and has an opening of about $2 \frac{7}{8}$ inches diameter. Players may use their own tube provided the opening is not larger than 3 inches, and the tube is not more than 2 inches longer or shorter than the dimensions given.

Objective

Shoot the cue ball through the tube, pocketing F1 ball in pocket F. The cue ball stays within the tube and spins back, coming out of the tube on the other side (where the cue ball started), and down the table to make A1 ball in pocket A.

Special Notes

The cue ball and F1 ball are setup at opposite ends of the tube.

Shot 86

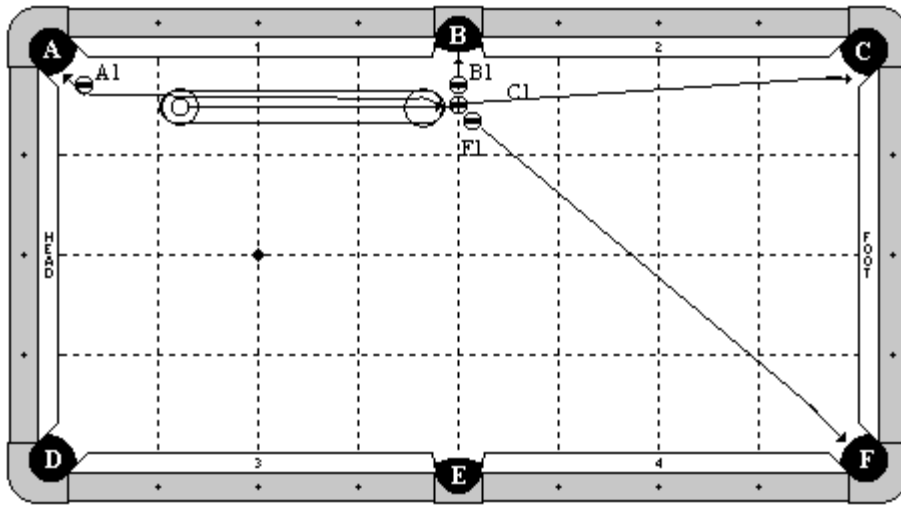

Category

Miscellaneous

Difficulty: 7

Cue Ball

Fully in the tube (measured by the edge of the ball).

Object Ball

A three-ball cluster is near pocket B and adjustable. A1 ball is hanging near pocket A.

Props

A tube is in hand as diagrammed. The opening is $2 \frac{7}{8}$ inches and it is 33 inches long. Players may use their own tube provided it doesn't have an opening wider than 3 inches, and the tube is not more than 2 inches longer or shorter than the dimensions given.

Objective

Shoot the cue ball through the tube, making the 3 ball cluster in pockets B, C, and F. The cue ball will draw back through the tube and make A1 ball.

Special Notes

None

Shot 87

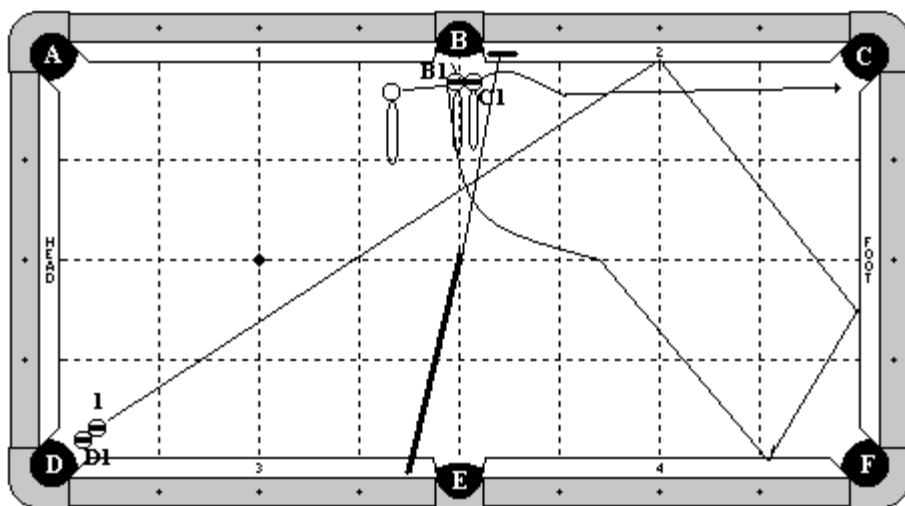

Category

Miscellaneous

Difficulty: 8

Cue Ball

In hand, balanced on a penny coin wrapper, no closer than 1 ball's width from B1 ball.

Object Ball

B1 and C1 balls are frozen near pocket B, both on penny coin wrappers. Two balls form a combination near pocket D.

Props

A bridge is across the table on the rail tops. A chalk cube may optionally be placed under the bridge butt to raise it up. Coin wrappers support the cue ball, B1, and C1 balls as already mentioned.

Objective

Shoot the cue ball into B1 ball. B1 and C1 balls go into pockets B and C respectively. The cue ball jumps over the bridge, goes 3 rails as diagrammed, and makes the combination in pocket D.

Special Notes

C1 ball must go over the bridge on its way to pocket C.

Shot 88

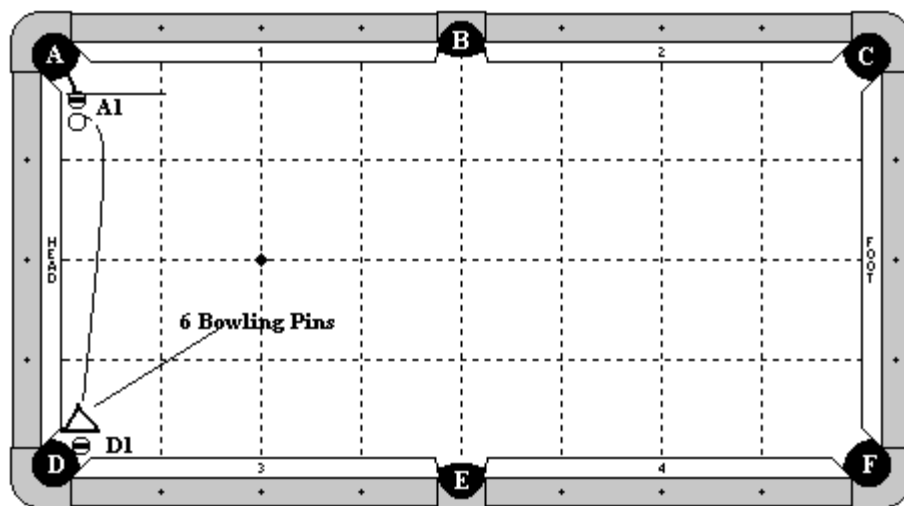

Category

Masse

Difficulty: 9

Cue Ball

In hand

Object Ball

Edge of A1 ball is even with the pocket point. D1 ball is hanging near pocket D.

Props

6 mini bowling pins are setup in a triangle. The last row of 3 pins is even with the pocket point. The pins are 4 inches tall and 1 ½ inches wide.

Objective

Masse the cue ball into A1 ball, making it in pocket A. The cue ball will masse back into the pins, knocking all of them down, and then make D1 ball in pocket D.

Special Notes

The cue ball or the pins may make D1 ball. Any pin leaning on the rail will be considered 'knocked down'.

Shot 89

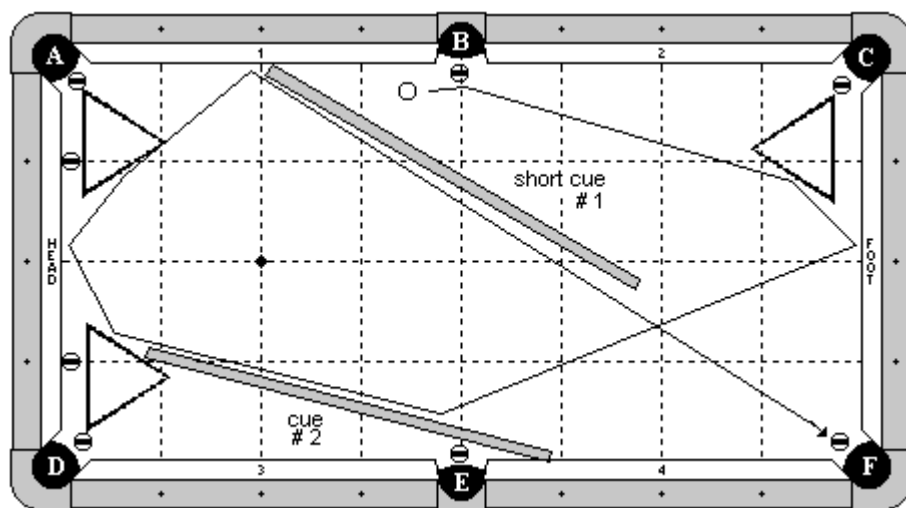

Category

Miscellaneous

Difficulty: 9

Cue Ball

In hand as diagrammed

Object Ball

6 object balls are hanging as diagrammed, one in each pocket. Two spacer balls may be used (optional) between racks and head rail.

Props

3 racks are in hand as diagrammed, near pockets A, C and D. 2 cue sticks are in hand as diagrammed. Cue # 1 must have the butt touching rail 1. Cue 2 must be touching ball E and the indicated rack.

Objective

Shoot the cue ball, follow the path indicated, and make all object balls in the following order: B, C, E, D, A, F.

Special Notes

The cues can be of any length.

Shot 91

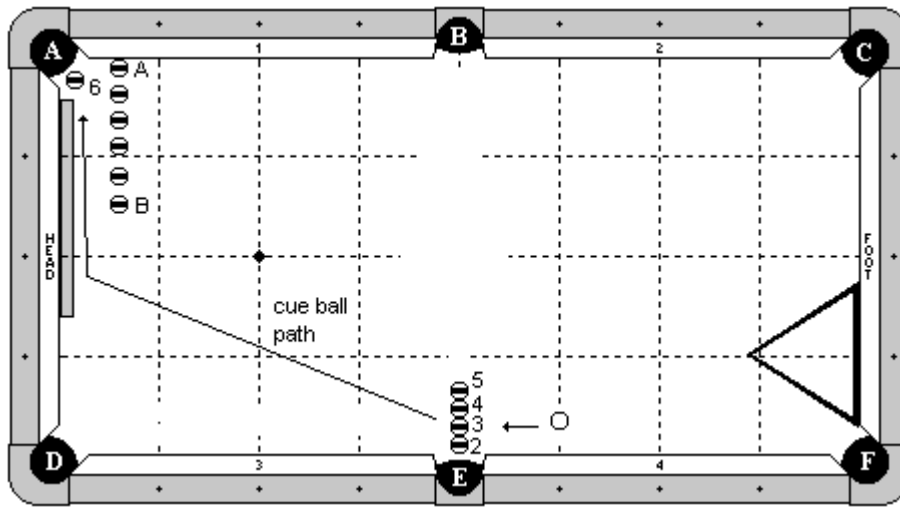

Category

Miscellaneous

Difficulty: 8

Cue Ball

In hand along the 3rd diamond.

Object Ball

2,3,4,5 balls are frozen in line near pocket E. The 2 ball must be centered in pocket B. The 6 ball is hanging near pocket A. 6 blocking balls are on the ½ diamond line. The first blocking ball is frozen to the cushion and the last blocking ball is at 1 ½ diamonds. The other blocking balls are evenly spaced between them.

Props

The butt of a cue stick and a rack are placed as diagrammed. The cue stick butt must be frozen to the cushion.

Objective

Shoot the cue ball to the line of 4 balls. Make the 2 ball in E, 3 ball in D, 4 ball in F, and 5 ball in B. The cue ball will then travel along the indicated path to the cue stick, and roll down to make the 6 in pocket A.

Special Notes

The cue ball may contact cushions 3 or 4, but no other cushions until after the 6 ball is made.

Shot 92

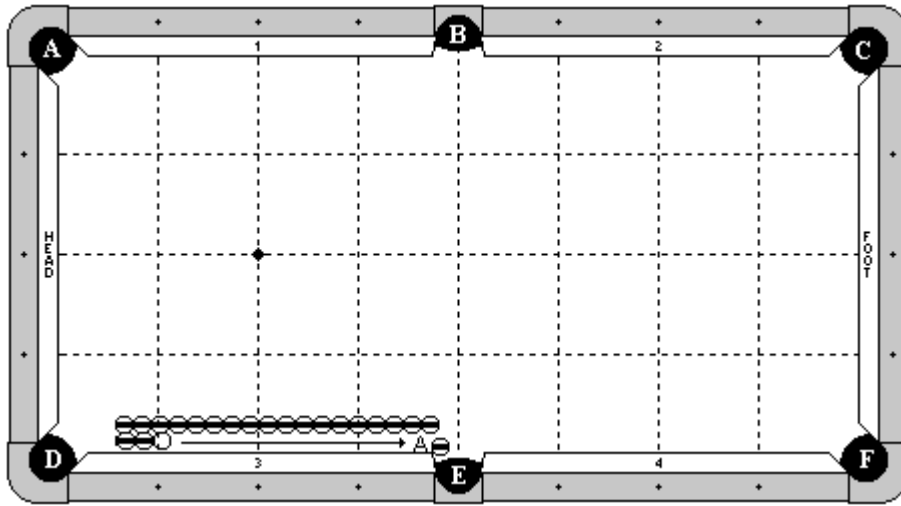

Category

Masse

Difficulty: 9

Cue Ball

Frozen to the cushion and to the 2 object balls immediately next to it.

Object Ball

18 balls are lined up 1 ball's width from the cushion as diagrammed. The cue ball is frozen to the 16th ball in this line. There are two additional object balls to the left of the cue ball, frozen in line and to the cushion. 'A' ball is hanging near pocket E.

Props

None

Objective

Masse the cue ball and travel between the balls and the cushion, making 'A' ball in pocket E.

Special Notes

At least 14 of the 15 object balls to the right of the cue ball must move. The player must use a special cue ball with silicone spray on it.

Shot 93

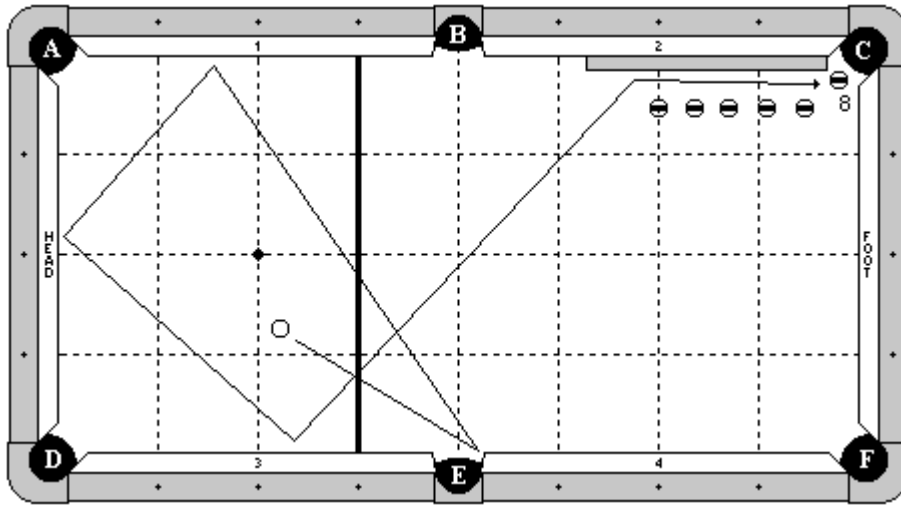

Category

Miscellaneous

Difficulty: 8

Cue Ball

In hand behind the 3rd diamond line.

Object Ball

8 ball hanging near pocket C. 5 blocking balls along the 1/2 diamond line. The first blocking ball is on the foot string and the last ball is 1/2 diamond from the foot cushion. The others are evenly spaced between them.

Props

The butt of a cue is in hand along cushion 2 as diagrammed.

Objective

Shoot the cue ball off the side pocket point. It will travel 3 rails as diagrammed, hit the cue, and then make the 8 ball.

Special Notes

None

Shot 94

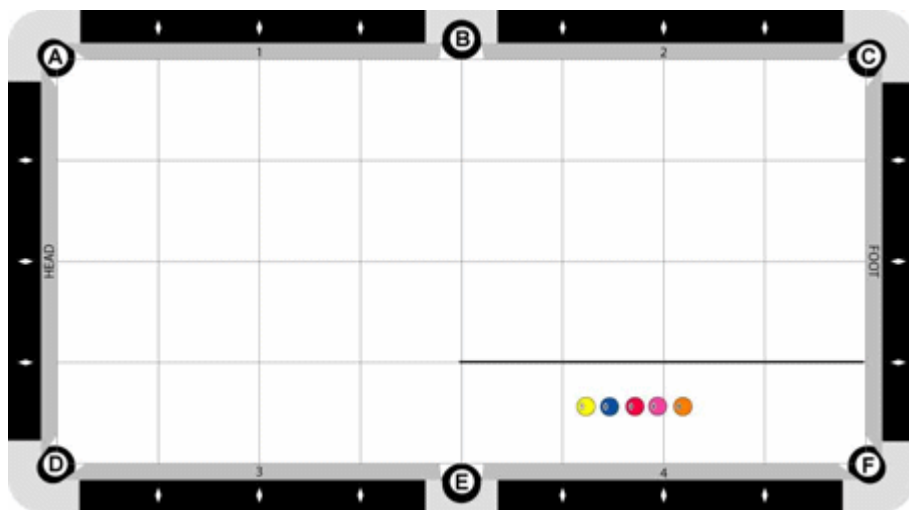

Category

Speed

Difficulty: 8

Cue Ball

None

Object Ball

5 balls are in hand within 1 diamond from the cushion.

Props

None

Objective

Jump each ball in the line (left to right) into the opposite cushion, causing it to fly back in the air. Catch it before it touches the table and place it in pocket E. Proceed to the next ball in line and continue until all 5 balls are in pocket E.

Special Notes

This shot must be performed in 15 seconds. If a ball does not manage to jump, or is dropped, the shot is no good.

Shot 95

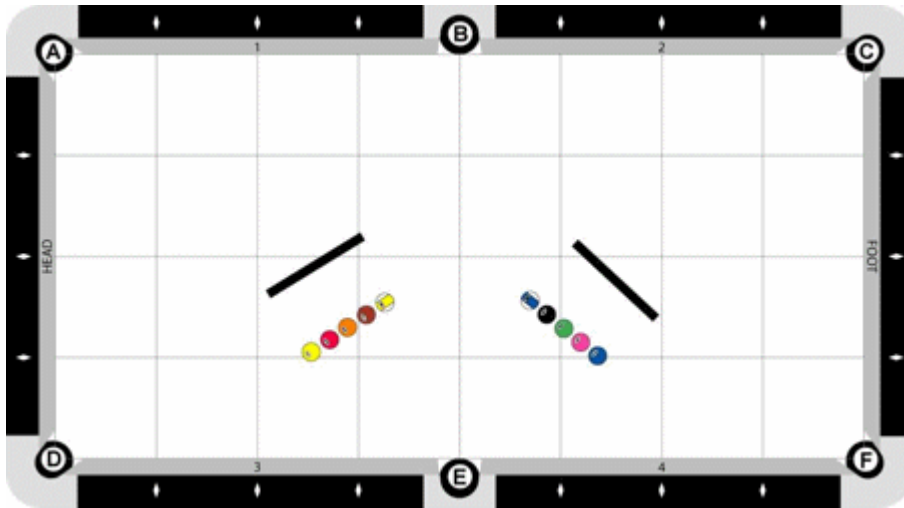

Category

Jump / Speed

Difficulty: 10

Cue Ball

None

Object Ball

2 groups of balls are used and are in hand, but may not be past the long center line of the table. Balls 1,3,5,7,9 are on the left with the 1 ball being the left most ball. Balls 2,4,6,8,10 are on the right with the 2 ball being the right most ball.

Props

2 barriers measuring 1 ½ inches tall by ¾ inches wide are in hand and no more than 2 ball's width from the line of balls.

Objective

Pocket all 10 object balls in numerical order. The group on the left (1,3,5,7,9) must be made right handed. The group on the right (2,4,6,8,10) must be made left handed.

Special Notes

The player must perform this shot within 25 seconds. Only 1 cue stick is allowed. Players **MUST** start this shot with their right hand, even if the player reverses the balls and shoots the mirror image.

Shot 96

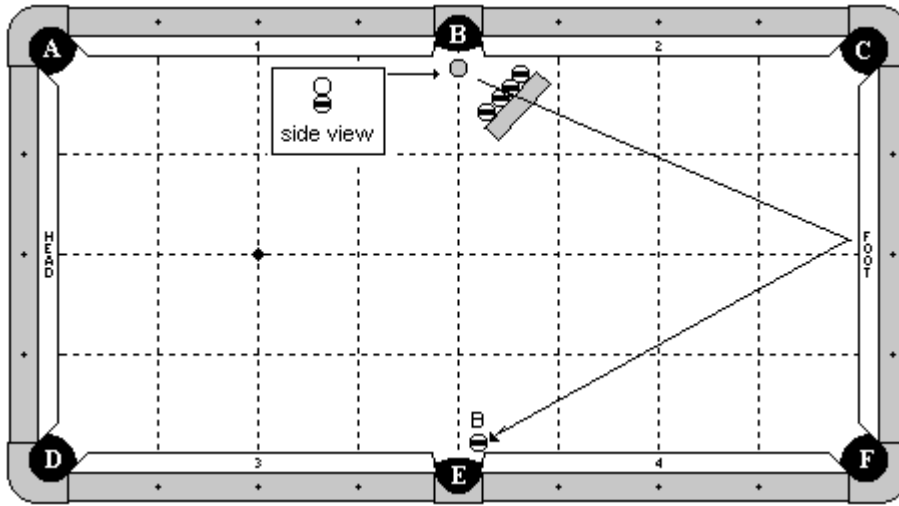

Category

Miscellaneous

Difficulty: 7

Cue Ball

On top of a stacking ball near pocket B as diagrammed.

Object Ball

B ball is hanging near pocket E. 4 blocking balls are frozen together in front of the rack as diagrammed.

Props

A stacking ball is near pocket B. A rack is standing upright as shown.

Objective

Shoot the cue ball off the stacking ball, through the rack, and pocket B ball in E pocket.

Special Notes

The cue ball must stay on the table, but it can scratch. The blocking balls and the rack may not be contacted by any means until after B ball is made.

Shot 97

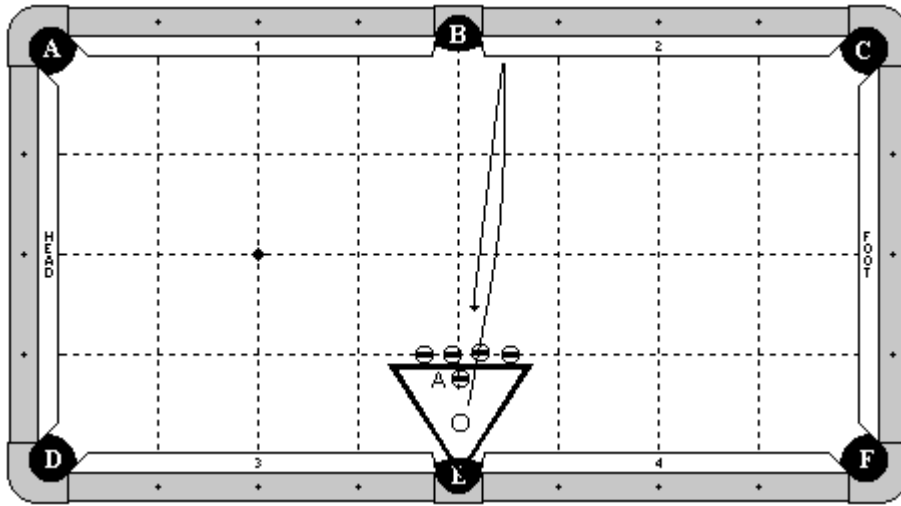

Category

Jump

Difficulty: 6

Cue Ball

In hand inside the rack.

Object Ball

'A' ball in hand within the rack. 4 blocking balls are outside the rack, frozen to it and evenly spaced as diagrammed.

Props

A rack is in hand as diagrammed.

Objective

Jump the cue ball over the rack and object balls, and bank it back to pocket 'A' ball into pocket E.

Special Notes

The cue ball cannot hit any of the 4 blocking balls or the rack until it hits cushion 2.

Shot 98

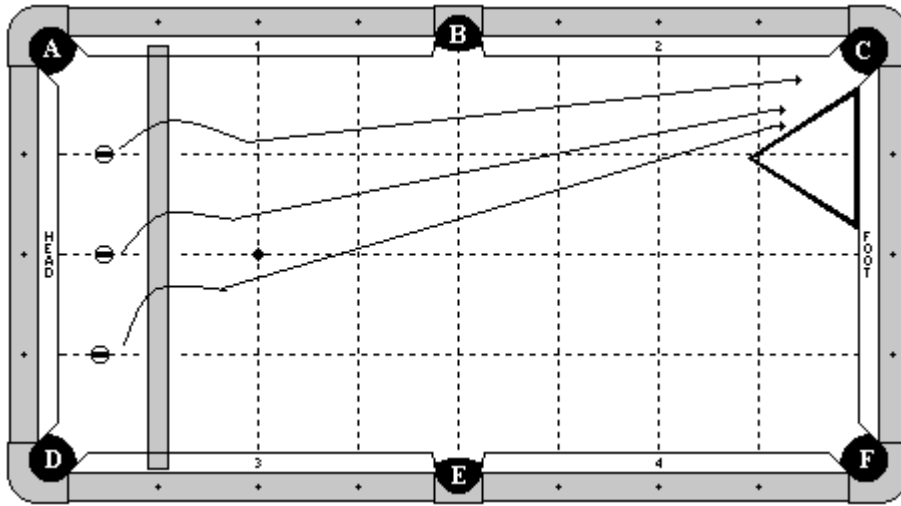

Category

1-handed jump

Difficulty: 7

Cue Ball

None

Object Ball

3 object balls are in hand, each on a diamond line as shown.

Props

A rack is in hand near pocket C. A cue stick is resting on the rail tops on the 1st diamond line.

Objective

Jump each ball 1-handed over the cue stick, one at a time, into pocket C.

Special Notes

The balls may hit the stick, but it may not fall off the rail tops.

Shot 99

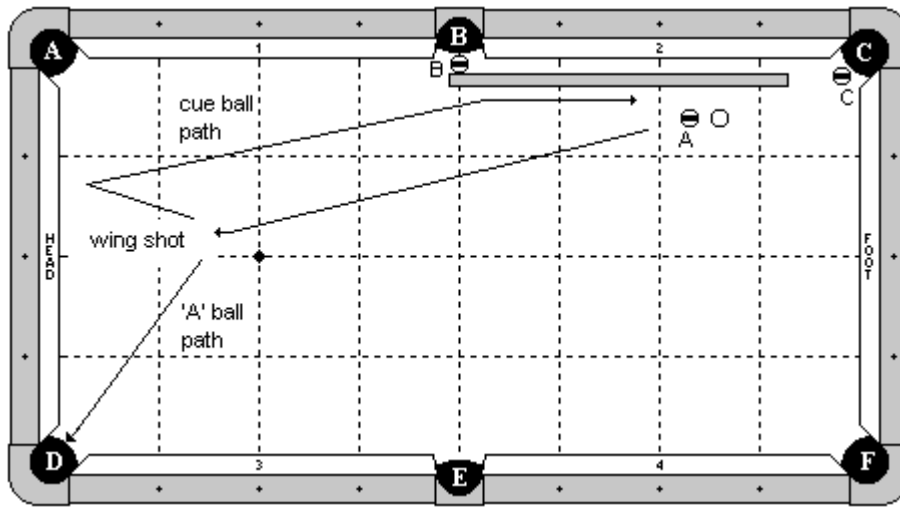

Category

Wing

Difficulty: 8

Cue Ball

Starts in your hand as in a standard wing shot.

Object Ball

'A' ball starts in your hand as in a standard wing shot. B and C balls are hanging as diagrammed.

Props

A cue stick is positioned as diagrammed.

Objective

Roll 'A' ball down the table and execute a wing shot, making A ball in pocket D. The cue ball will then bank back and hit the cue stick, causing the ball to go into pocket B. The cue ball will roll down the cue stick and make the ball in pocket C.

Special Notes

The cue ball must be positioned behind the foot string when hitting the wing shot.

Shot 100

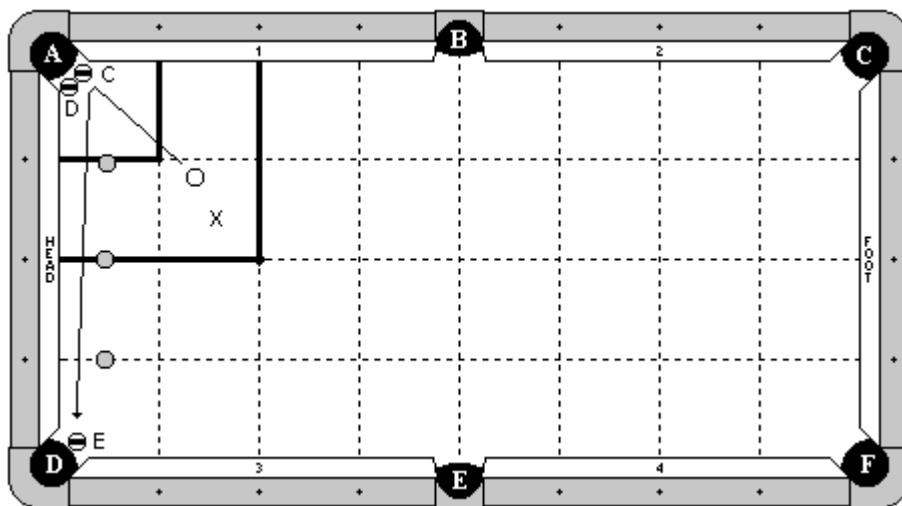

Category

Miscellaneous

Difficulty: 6

Cue Ball

In hand within the indicated zone.

Object Ball

C and D balls in hand near pocket A (within the jaws of the pocket). E ball is hanging near pocket D (also within the jaws of the pocket).

Props

Three bottles are on the diamond lines, all of them are $\frac{1}{2}$ diamond from the head cushion.

Objective

Shoot the cue ball and make both C and D balls in pocket A. The cue ball will draw between the bottles and the cushion to make E ball.

Special Notes

The bottles may not be contacted by any means until after all balls have been made.

Shot 101

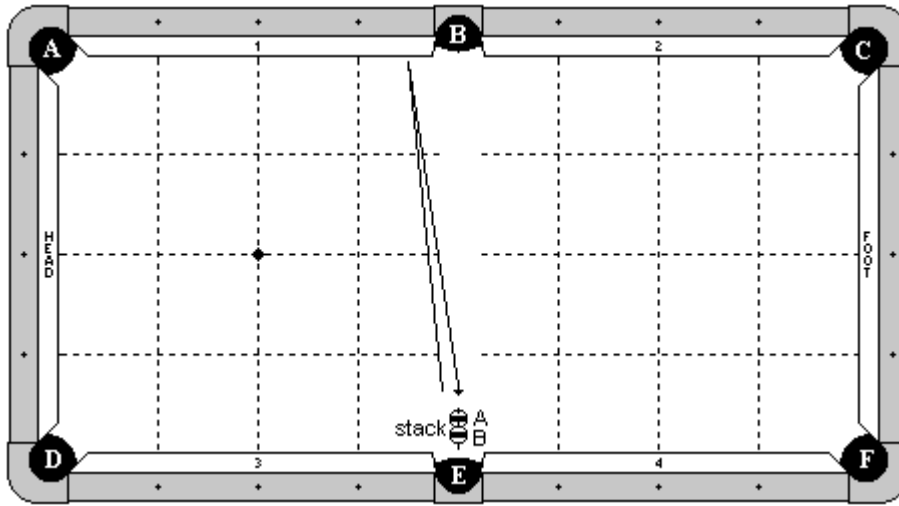

Category

Miscellaneous

Difficulty: 6

Cue Ball

None

Object Ball

'A' ball balanced on a stacking ball.

Props

A stacking ball is near pocket E.

Objective

Hit the bottom stacking ball into the opposite cushion. That ball will bank back and make ball 'A' in pocket E.

Special Notes

None

Shot 102

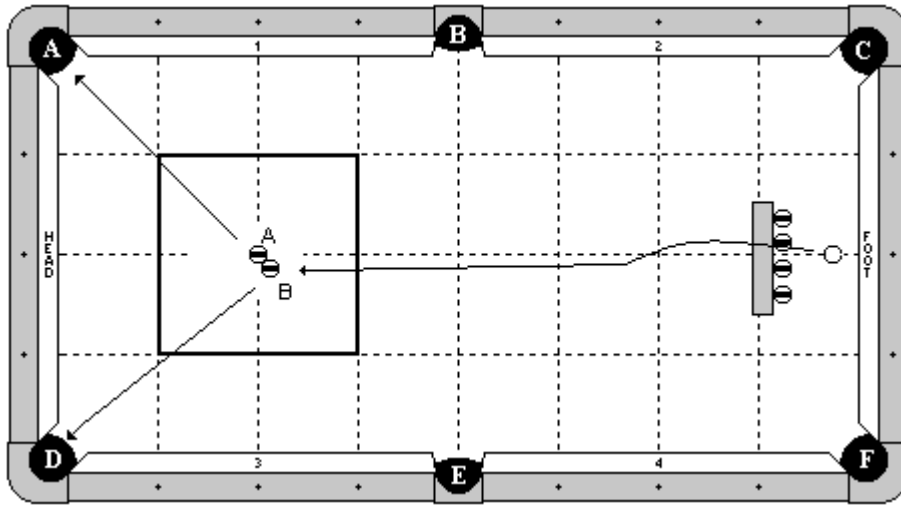

Category

Jump

Difficulty: 6

Cue Ball

In hand on the center line, behind the rack and blocking balls.

Object Ball

'A' and 'B' balls are in hand within the indicated zone. 4 blocking balls are evenly spaced against the rack as diagrammed.

Props

A rack is standing upright on the 1st diamond line, centered.

Objective

Jump the cue ball over the blocking balls and through the rack, pocketing A and B balls as diagrammed.

Special Notes

None

Shot 103

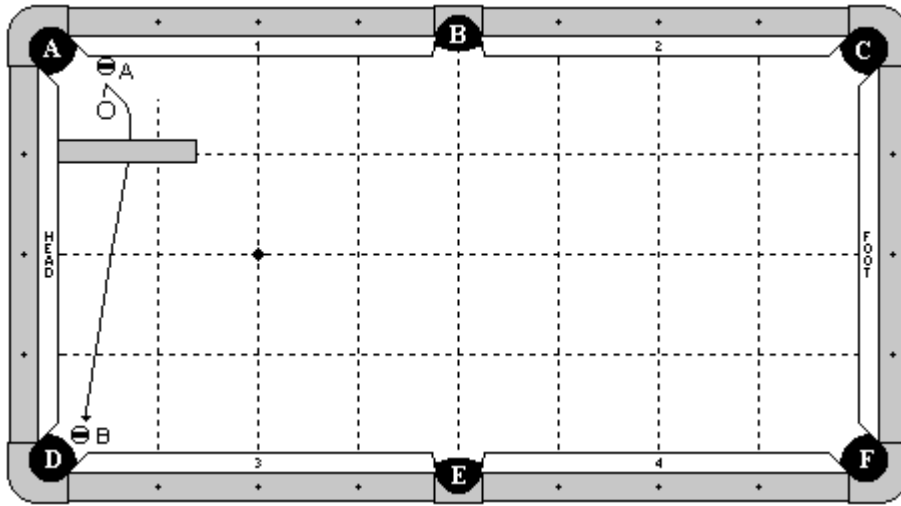

Category

Miscellaneous

Difficulty: 6

Cue Ball

In hand within the 1x1 diamond zone near pocket A.

Object Ball

'A' ball is in hand, frozen to the cushion, within the 1x1 zone. B ball is hanging near pocket D.

Props

A rack is standing upright on the 1st diamond line.

Objective

Shoot the cue ball into 'A' ball. The cue ball will jump back through the rack, and make B ball in pocket D.

Special Notes

The cue stick must go through the rack when shooting. The rack may be contacted, but not knocked over, by any means until all balls come to rest.

Shot 104

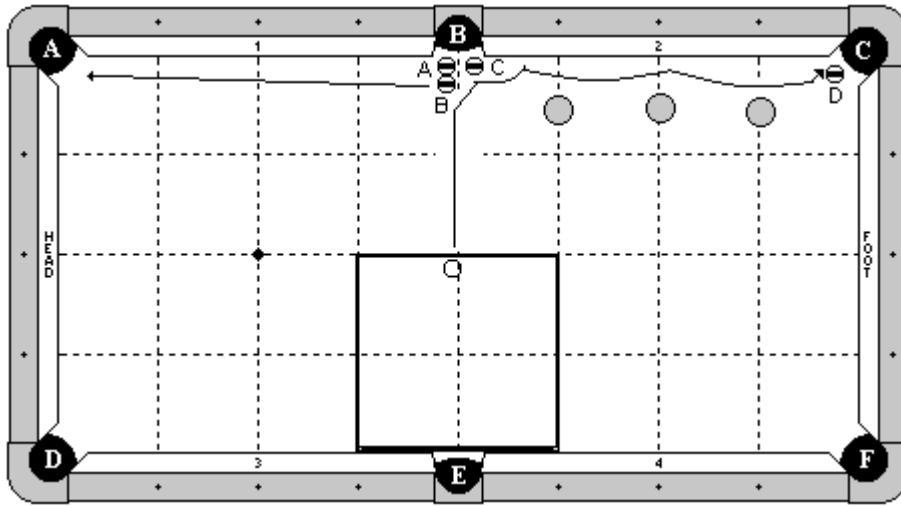

Category

Miscellaneous

Difficulty: 6

Cue Ball

In hand within the indicated zone.

Object Ball

A,B,C balls are in hand near pocket B as diagrammed. D ball is hanging near pocket C.

Props

Three bottles are in position as diagrammed. Each will be on a diamond line, and all will be $\frac{1}{2}$ diamond from the cushion.

Objective

Shoot the cue ball into 'B' ball. This will cause 'A' ball to go in pocket B, and B ball to go in pocket A. The cue ball will then hit the C ball and make it in pocket B. The cue ball will then force follow down the rail to make D ball.

Special Notes

The bottles may not be hit by any means until after all balls have been made. The cue ball must hit cushion # 2 at least 1 time before making D ball.

Shot 105

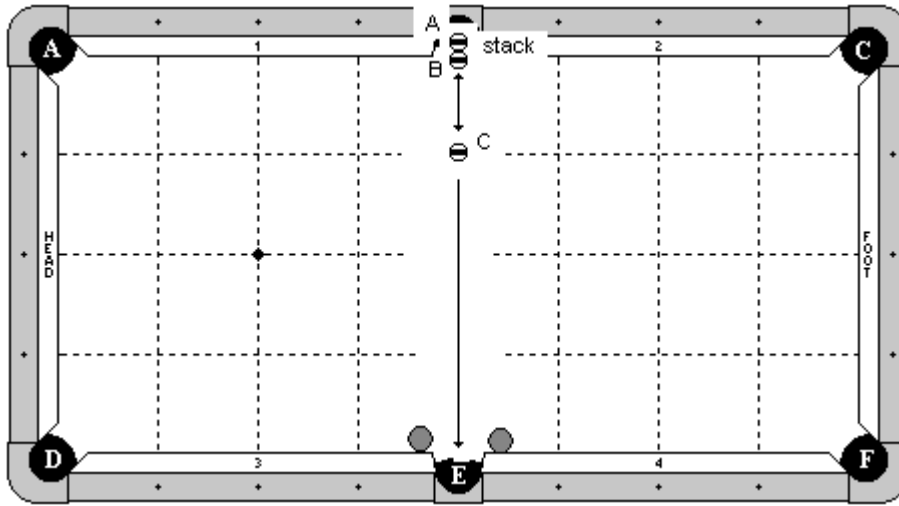

Category

Miscellaneous

Difficulty: 7

Cue Ball

None

Object Ball

'A' ball is balanced on a stacking ball, near pocket B. C ball is along the center line, and 1 diamond from pocket B.

Props

A special stacking ball is near pocket B. Two plastic champagne glasses (with an object ball in each) are frozen to the cushion near pocket E. Both have their edge even with the pocket point.

Objective

Hit the stacking ball into C ball, making it in pocket E. The stacking ball will draw back and make 'A' ball in pocket B.

Special Notes

The glasses may not be hit by any means.

Shot 106

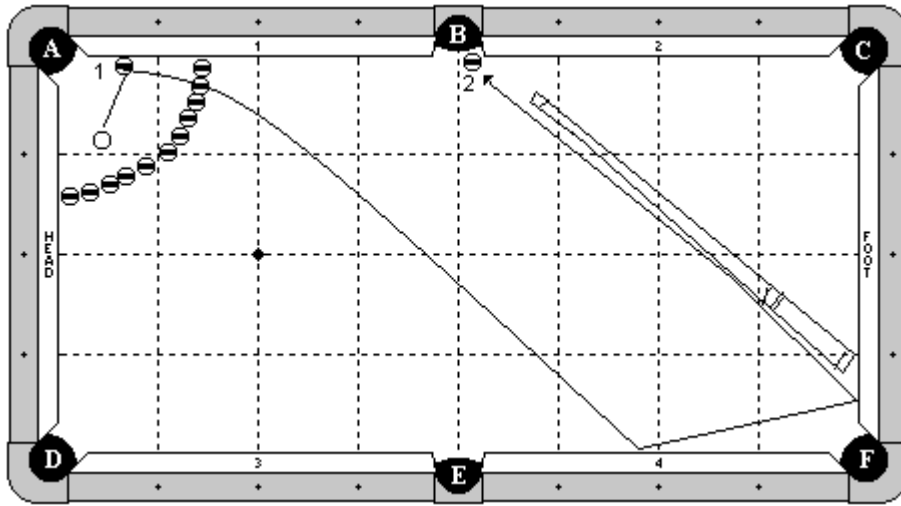

Category

Miscellaneous

Difficulty: 8

Cue Ball

In hand within the circle of balls.

Object Ball

Ball 1 is in hand, frozen to cushion 1 as diagrammed. Ball 2 is hanging at pocket B. Circle of blocking balls are as diagrammed, with the first and last ball each at $1\frac{1}{2}$ diamonds.

Props

A cue stick is on the table, with the butt end frozen to the foot cushion at the 1st diamond.

Objective

Shoot the cue ball to the 1 ball. The cue ball will jump over the blocking balls, then travel to rail 4, foot rail, touch the cue stick, and make the 2 ball in pocket B.

Special Notes

The cue ball does not have to touch the stick. The cue ball can touch the blocking balls.

Shot 107

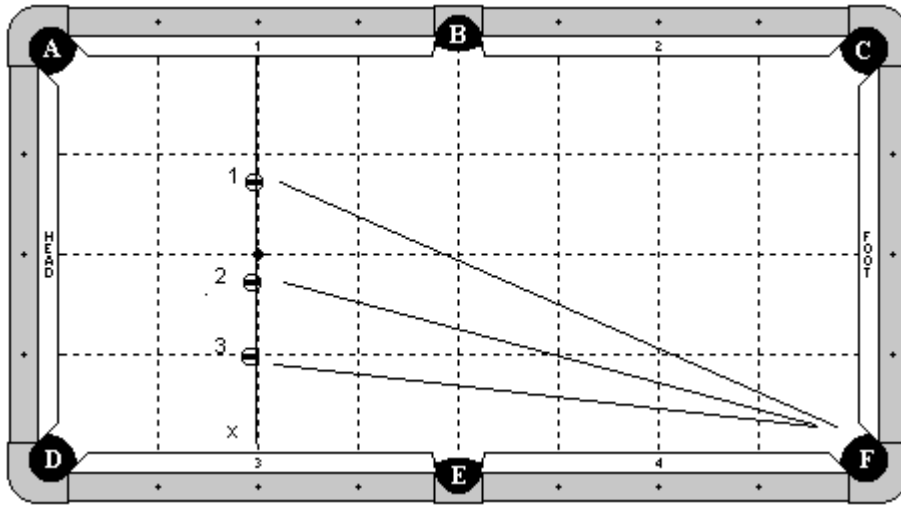

Category

Miscellaneous

Difficulty: 8

Cue Ball

None

Object Ball

Balls 1,2,3 are in hand on the head string.

Props

None

Objective

Shoot all three balls into pocket F. You must hit the balls in reverse numerical order (3,2,1), but they must be pocketed in numerical order (1,2,3).

Special Notes

The balls may contact each other while they are rolling.

Shot 108

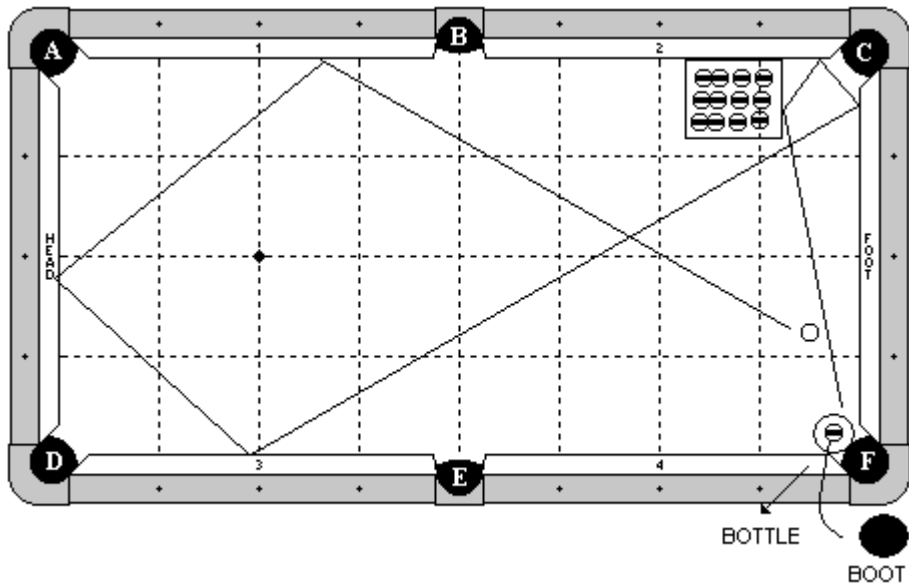

Category

Miscellaneous

Difficulty: 9

Cue Ball

In hand

Object Ball

An object ball is on a bottle near pocket F. 14 object balls are in a ball tray near pocket C.

Props

A tray of balls is frozen to cushion 2. A bottle is hanging at pocket F. Any bottle may be used provided that it is no shorter than 25cm. The bottle may be filled with any substance to give it weight. A boot is in hand on the floor. Any boot may be used provided it is no larger than a size 13.

Objective

Shoot the cue ball 5 cushions as diagrammed. It will then hit the tray, bounce over to hit the bottle, causing the bottle to fall and the object ball will fall directly into the boot.

Special Notes

The cue ball may contact an extra cushion near pocket F.

Shot 109

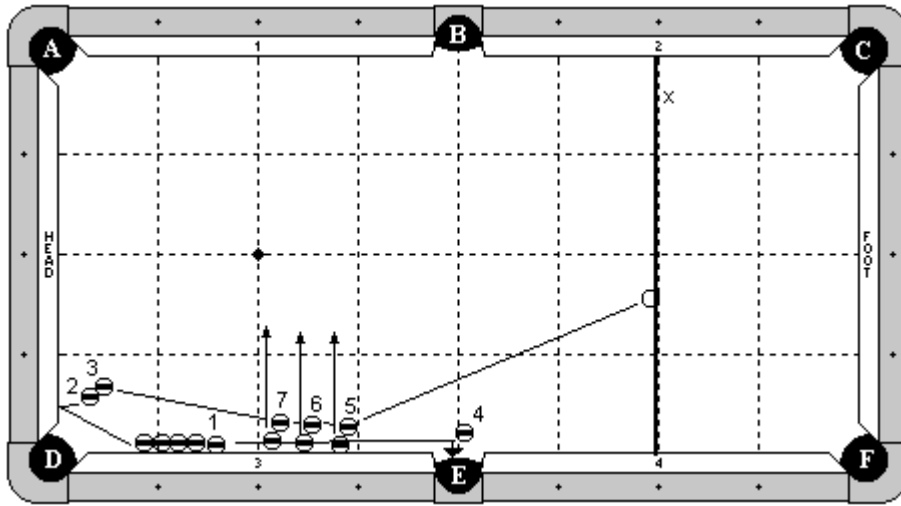

Category

Miscellaneous

Difficulty: 7

Cue Ball

In hand on the X line.

Object Ball

A row of 5 balls is frozen to each other and to cushion 3. 3 clusters of 2 balls each are as diagrammed, with one of the balls in each cluster frozen to the cushion. The 4 ball is hanging. The 2 and 3 balls are in hand as diagrammed.

Props

None

Objective

Shoot the cue ball into the 5 ball. The 5 ball will hit the 6 and the 6 will hit the 7, causing all 6 of those balls to scatter. The 7 will hit the 3 ball, which will cause the 2 ball to bank and hit the line of 5 balls, causing the 1 ball to travel up the rail, carom off the 4 ball and go into pocket E.

Special Notes

All of the balls must be hit as explained and diagrammed. Ball # 1 may not contact any ball except ball # 4.

Shot 110

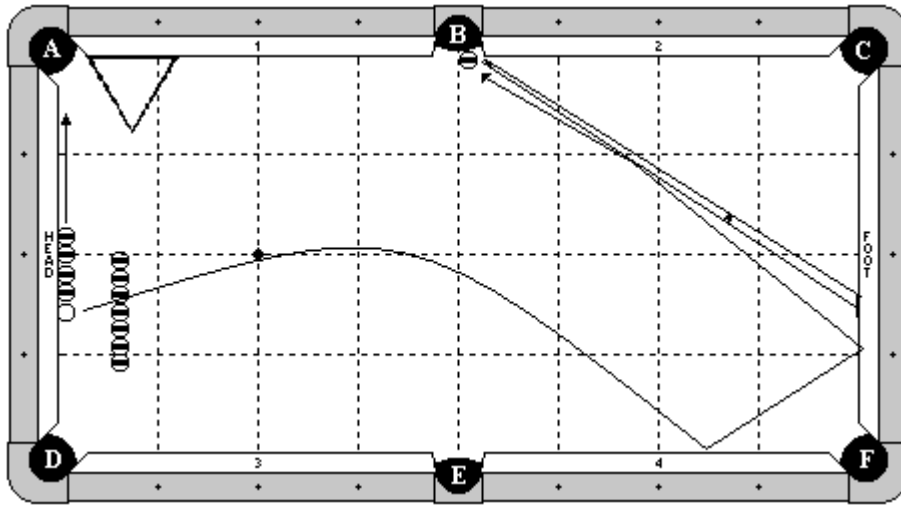

Category

Stroke

Difficulty: 9

Cue Ball

Frozen to the cushion and to the last ball in the row.

Object Ball

Row of 4 balls are frozen to each other and to the cushion. They may be adjusted along the cushion. Row of 7 blocking balls is in hand, but must be placed so the cue ball is about centered so it will have to jump over them. An object ball is hanging near pocket B.

Props

A cue stick is on the table, with the butt end frozen to the cushion at 1 ½ diamonds. A rack is on the cushion near pocket A.

Objective

Shoot the cue ball into the line of balls. All 4 balls must go in pocket A. The cue ball will jump over the line of blocking balls, follow the indicated path, and make the ball in pocket B.

Special Notes

The blocking balls may not be contacted by any means until all balls have been made. The cue ball does not need to contact the cue stick.

Shot 111

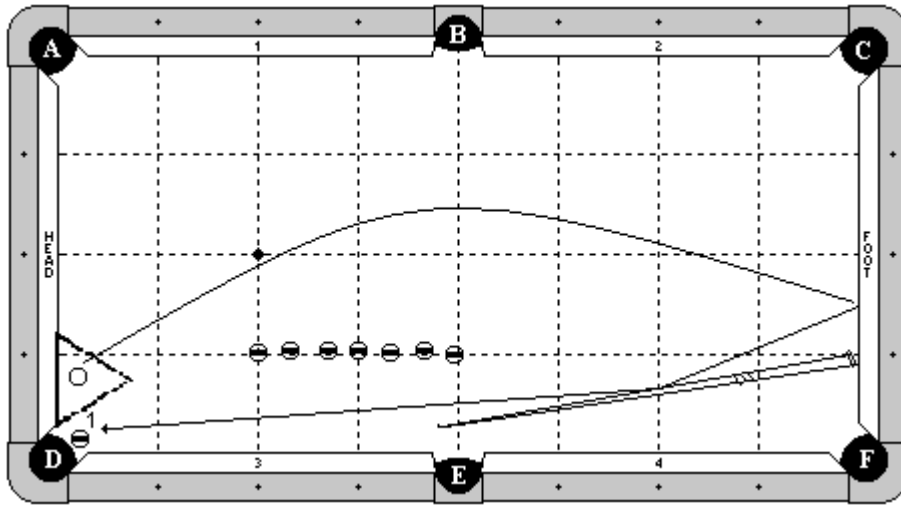

Category

Jump / Masse

Difficulty: 7

Cue Ball

In hand within the rack.

Object Ball

A line of blocking balls is on the 1st diamond line. Each of the blocker balls is propped up inside a plastic shot glass. The first ball is on the center line and the last ball is on the head string. The 1 ball is hanging near pocket D.

Props

A cue stick is on the table and in hand, with the butt end frozen to the cushion at the 1st diamond. A rack is frozen to the head cushion as diagrammed. Plastic shot glasses are under the line of blocker balls.

Objective

Jump the cue ball out of the rack. The cue ball will hit the foot cushion, then the stick, and make the 1 ball.

Special Notes

The blocking balls may not be contacted by any means. The cue ball does not need to contact the stick.

Shot 112

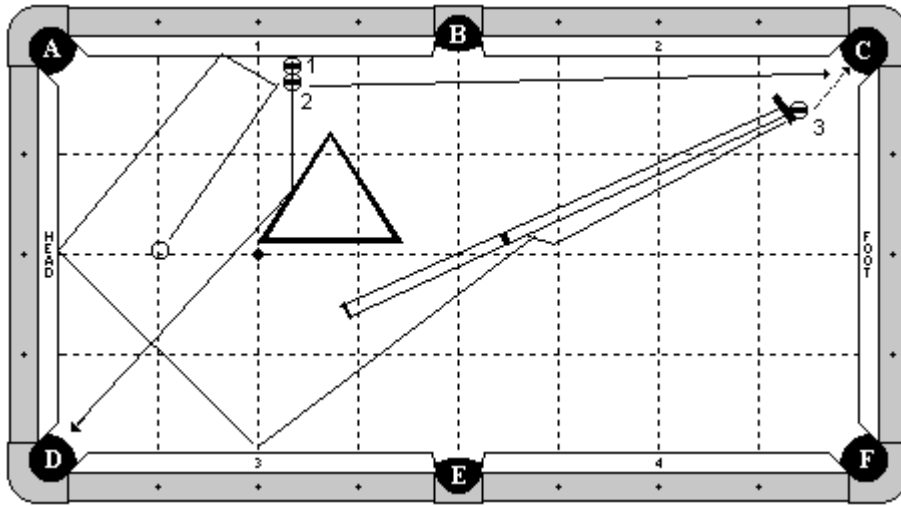

Category

Miscellaneous

Difficulty: 9

Cue Ball

In hand on the center line of the table.

Object Ball

The 1 ball is frozen to the cushion, and the 2 ball is frozen to the 1 ball. Both balls may be adjusted up and down the rail. The 3 ball is frozen to the bridge as diagrammed.

Props

A rack is in hand. A bridge is on the table in hand.

Objective

Shoot the cue ball to the 2 ball, making it in pocket C. The 1 ball will bank into the rack and go into pocket D. The cue ball will travel three rails, hit the bridge and eventually make the 3 ball in pocket C.

Special Notes

None

Shot 113

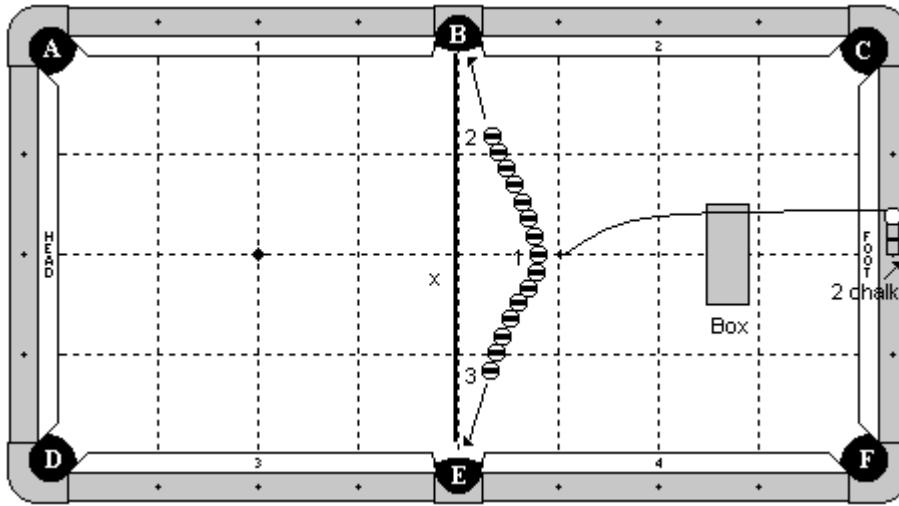

Category

Miscellaneous

Difficulty: 9

Cue Ball

On top of a stack of 2 chalk cubes on the foot rail top, centered.

Object Ball

Ball # 1 (center ball) is in hand on the long center line of the table, but is must be behind X line. 7 balls are on either side of the cue bal, all frozen in line. The line doesn't have to be straight.

Props

A standard pool ball box is standing upright and is in hand, but it must be centered. Two chalks are under the cue ball.

Objective

Jump the cue ball over the box and hit ball # 1. This will cause the two end balls (ball # 2 and 3) to go into the side pockets.

Special Notes

The box may not be touched by the cue ball until it hits the 1 ball. The 1 ball (center ball) must be hit first.

Shot 114

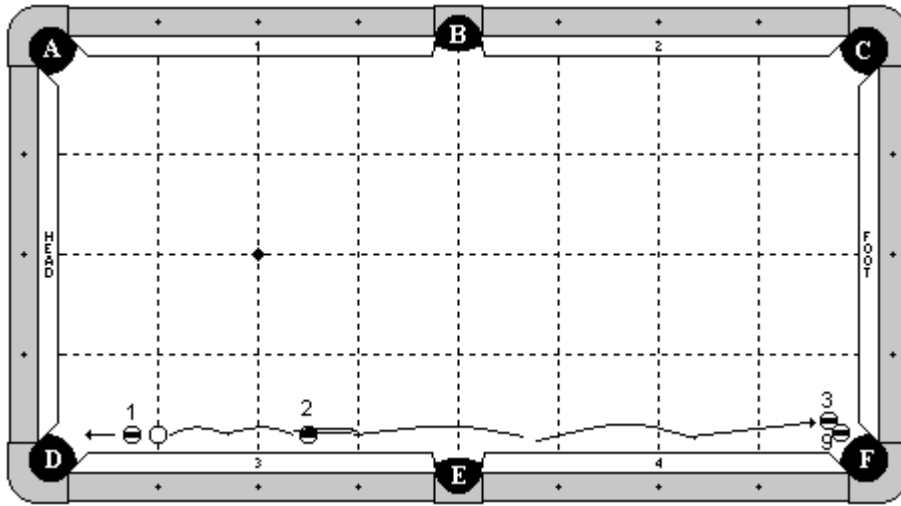

Category

Masse

Difficulty: 10

Cue Ball

Close to the cushion on the 1st diamond line.

Object Ball

The 1 ball is at least ½ inch from the cue ball. The 2 ball is ½ ball's width from the cushion at the 2 ½ diamond line. The 3-9 combination is hanging at pocket F.

Props

None

Objective

Masse the cue ball, making the 1 ball in pocket D. The cue ball will travel up the rail, hitting the 2 ball, causing it to roll out of the way, and then the cue ball will continue to masse up the rail, making the combination in pocket F.

Special Notes

The foot rail cannot be touched before hitting the combination. The 2 ball must be hit by the cue ball. The player must use a special cue ball with silicone spray on it.

Shot 115

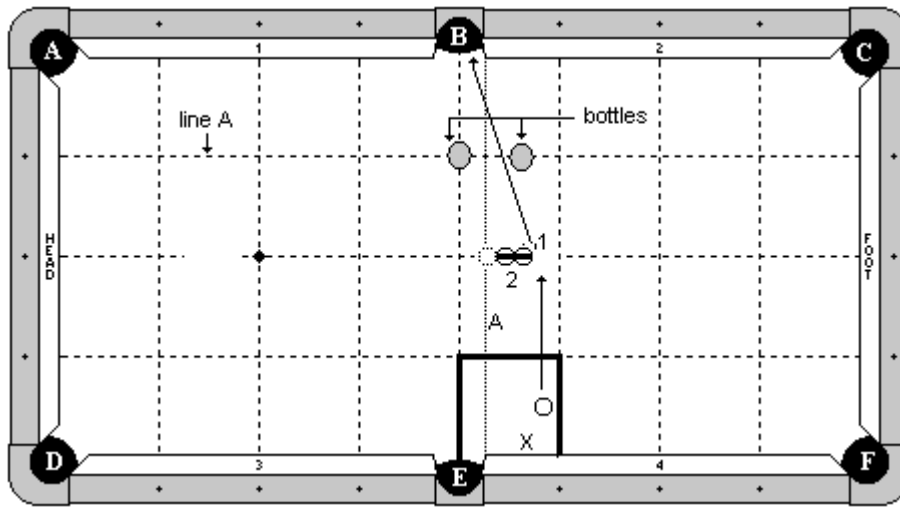

Category

Miscellaneous

Difficulty: 8

Cue Ball

In hand within the indicated zone.

Object Ball

Place three balls on the center line of the table (ghost ball, 2 ball, 1 ball) as diagrammed.

The ghost ball is centered on the line connecting the pocket points. All balls are frozen to each other. Once this setup is complete, remove the ghost ball.

Props

2 bottles are on the 1st diamond line with a 1 ½ ball's width gap. They may be adjusted along the 1st diamond line.

Objective

Shoot the cue ball into the 1 ball, pocketing the 1 ball in pocket B (through the bottles).

Special Notes

The 1 ball may be hit only once by the cue ball. Once the 1 ball starts rolling, it must go into the pocket without help by any other ball. The bottles may not be touched by any means until after the 1 ball is made.

Shot 116

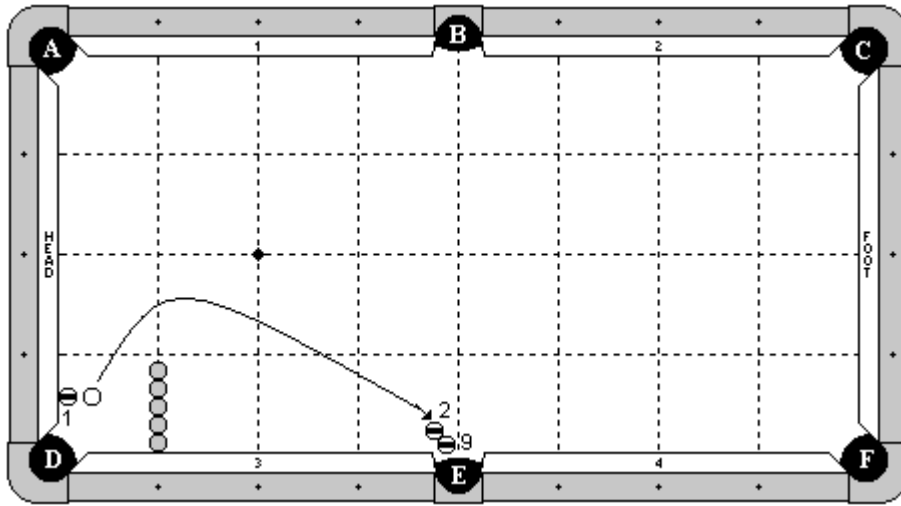

Category

Masse

Difficulty: 10

Cue Ball

2 centimeters from the 1 ball, straight out from the 1 ball (perpendicular to the head cushion).

Object Ball

1 ball is frozen to the cushion at $\frac{1}{2}$ diamond. The 2-9 combination is near pocket E.

Props

5 object balls, balanced on chocks, are frozen along the 1st diamond line as diagrammed.

Objective

Masse the cue ball into the 1 ball. The cue ball will bounce back, curve around the blocking balls, and make the combination.

Special Notes

The cue ball may not contact the head cushion until after the 9 ball is made (it may contact cushion 3). The blocking balls may not be contacted by the cue ball as it curves around them.

Shot 117

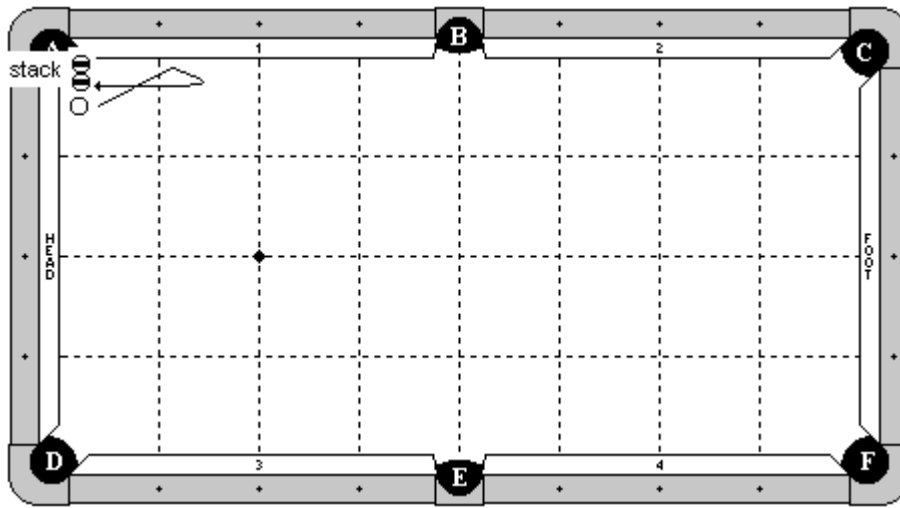

Category

Masse

Difficulty: 9

Cue Ball

In hand, but not frozen to the stacking ball.

Object Ball

An object ball is balanced on top of a stacking ball.

Props

A stacking ball is hanging near pocket A.

Objective

Masse the cue ball, hitting the bottom ball and making it in pocket A. The cue ball will travel up and down the rail as diagrammed. It will then come back and make the other object ball.

Special Notes

The cue ball must hit the cushion at least once before pocketing the second object ball.

Shot 118

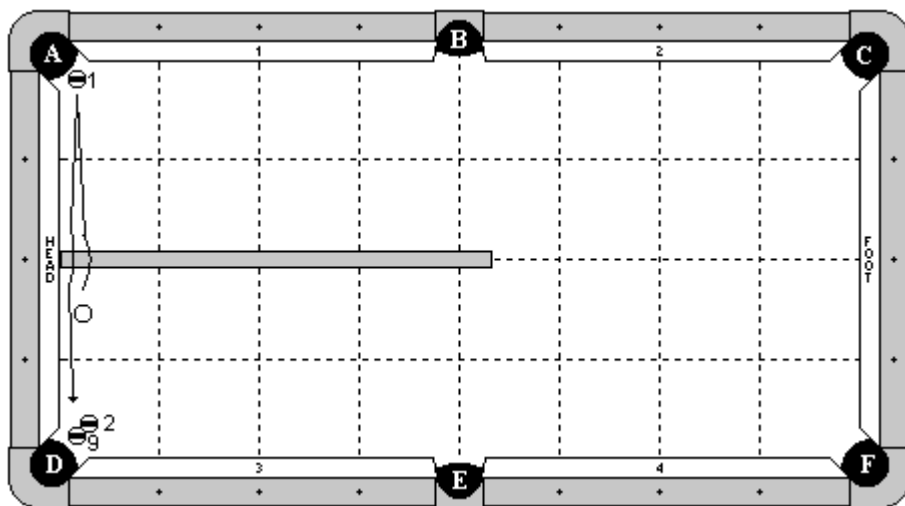

Category

Masse

Difficulty: 9

Cue Ball

In hand along the head rail, but no closer than 1 ball's width from the cue stick.

Object Ball

1 ball is in hand near pocket A. The 2-9 combination is hanging near pocket D.

Props

A standard cue (about 13mm tip) is placed on the table along the long center line, with the tip stuck under the center of the head cushion.

Objective

Masse the cue ball over the cue without touching it. Make the 1 ball and then come back, passing over the cue stick, and make the 2-9 combination.

Special Notes

None

Shot 119

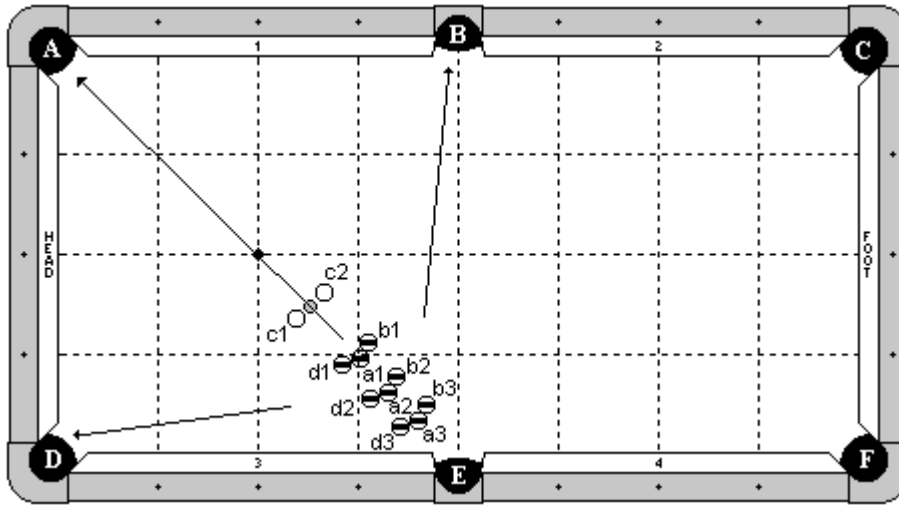

Category

Miscellaneous

Difficulty: 9

Cue Ball

Cue balls 1 and 2 have exactly 1 ball's width between them, and their back edge is exactly 3 ball's width from A1 ball. As long as they adhere to those requirements, they may be adjusted.

Object Ball

3 groups of balls (3 each) are as diagrammed. Each group of 3 has the 'D' ball frozen to the 'A' ball, which is frozen to the 'B' ball.

Props

A silver dollar is laying flat on the table, centered between the cue balls. Players may use a quarter or a half-dollar as well.

Objective

Shoot A1 ball, then A2 ball, then A3 ball. All balls will go in as pocket letter designates. The three 'A' balls will jump over the coin, through the cue balls, and go into pocket A.

Special Notes

The cue balls may not move by any means until after all 9 balls have been made. Players must use a free-hand (air) bridge, 2 handed. Players have a maximum of 9 seconds to hit all 3 balls. The coin may not move until the shot is complete.

Shot 120

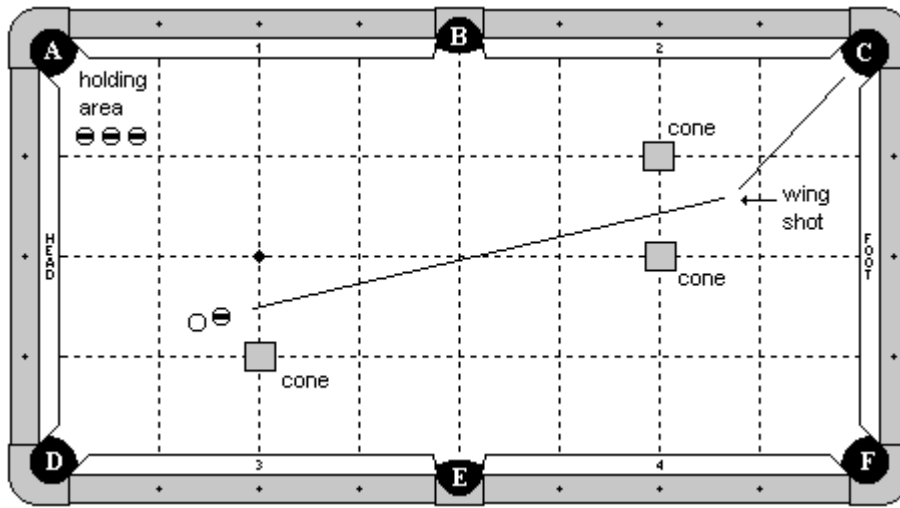

Category

Wing

Difficulty: 9

Cue Ball

Starts in your hand as in a standard wing shot.

Object Ball

Starts in your hand as in a standard wing shot. 3 additional balls are on the table.

Props

Three plastic or rubber cones are on the diamond intersection lines. Players may use bottles instead of cones.

Objective

Shot # 1: Roll the object ball and make a standard wing shot in pocket C.

Shot # 2: Roll the cue ball and make a reverse wing shot, caroming the object ball off the cue ball into pocket C.

Shot # 3: Repeat shot 1, making a standard wing shot.

Shot # 4: Repeat shot 2, making a reverse wing shot.

Special Notes

All balls must be rolled past the cones/bottles as diagrammed. No abort rolls. All cones/bottles may be touched but may not fall over by any means. If a cone/bottle is touched, it must remain where it moves to for the remainder of the shot, and the balls must still be rolled past them as diagrammed. All balls must come to a complete stop before shooting the next shot. When all balls stop rolling at the conclusion of the shot, all of the cones must be upright. All wing shots must be hit while the ball is still rolling.

Shot 121

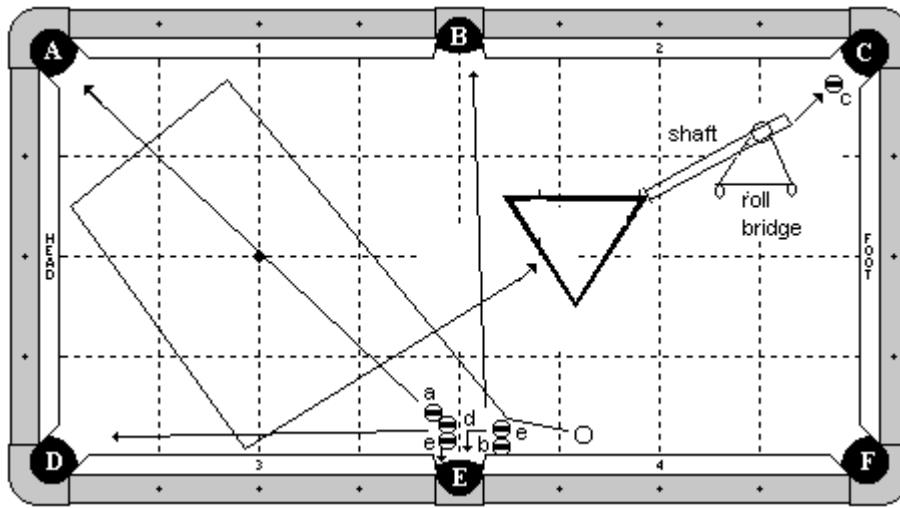

Category

Miscellaneous

Difficulty: 9

Cue Ball

In hand

Object Ball

5 balls are clustered near pocket E in the standard 'just showin off' shot formation. Players may adjust the balls. 'C' ball is on top of a piece of chalk (well up) and has its edge aligned with the pocket cut.

Props

A special rolling bridge on wheels is positioned as diagrammed. A shaft is on the table with the tip side sticking through the hole in the top of the rolling bridge. The tip is exactly 2 ball's width from the C ball. A rack is on the table and is frozen to the joint protector that is attached to the shaft. The shaft may be no longer than 29 inches. The joint protector may not be larger than 1 ½ inches diameter.

Objective

Shoot the cue ball, making all 5 object balls as in the standard 'just showin off' shot. The cue ball will travel 3 cushions, hit the rack, causing a chain reaction to roll the bridge on wheels and the shaft forward. The tip of the shaft will hit C ball, knock it off the chalk and into the pocket.

Special Notes

The overhang of the shaft through the rolling bridge may be a maximum of 4 inches. The rolling bridge is 3 ¾ inches wide with 2 wheels, 7/8 inches diameter. The sides are 3 inches long and the rubber hole at the top is ½ inches diameter, and 1 inch diameter on the outside. It is made out of metal. Player are free to use their own rolling bridge. If the company that makes this product changes the dimensions, players may still use their own prop without matching the dimensions given above.

Shot 122

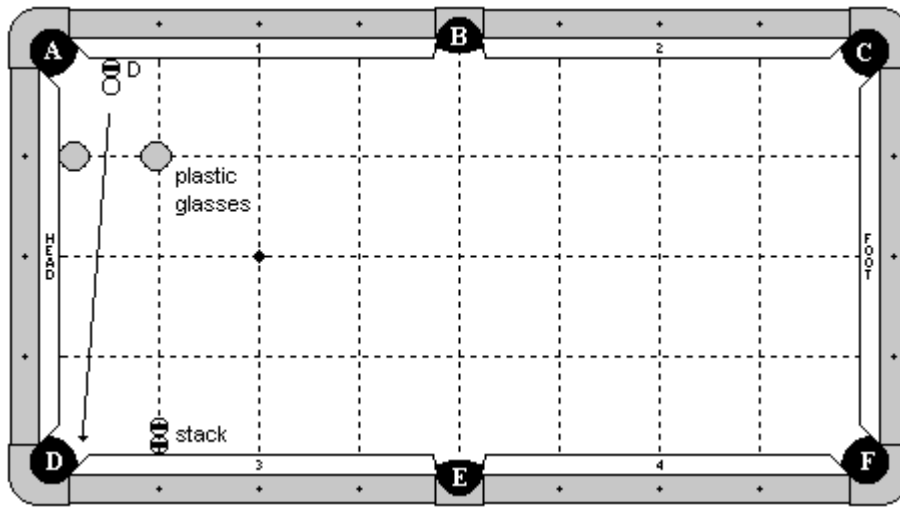

Category

Miscellaneous

Difficulty: 8

Cue Ball

In hand, frozen to D ball.

Object Ball

D ball is in hand, frozen to the cushion and the cue ball.

Props

Two plastic champagne glasses are on the 1st diamond line. The first is frozen to the cushion. The second is 3 ball's width (at the base) from the first glass. A stacking ball is on the 1st diamond, frozen to cushion 3, with an object ball on top of it. There is an object ball inside each glass.

Objective

Shoot the cue ball, banking D ball into pocket D. The cue ball and D ball must pass between the glasses.

Special Notes

The glasses may be hit, but not knocked over. The stack of 2 balls may not be touched or knocked over by any means until the shot is complete. The butt end of the player's cue stick may not be above the top of the upper edge of the 2 ball stack. Once the cue ball is struck, the butt may go above the ball (referee's decision is final). Multiple hits may occur between the cue ball and D ball.

Shot 123

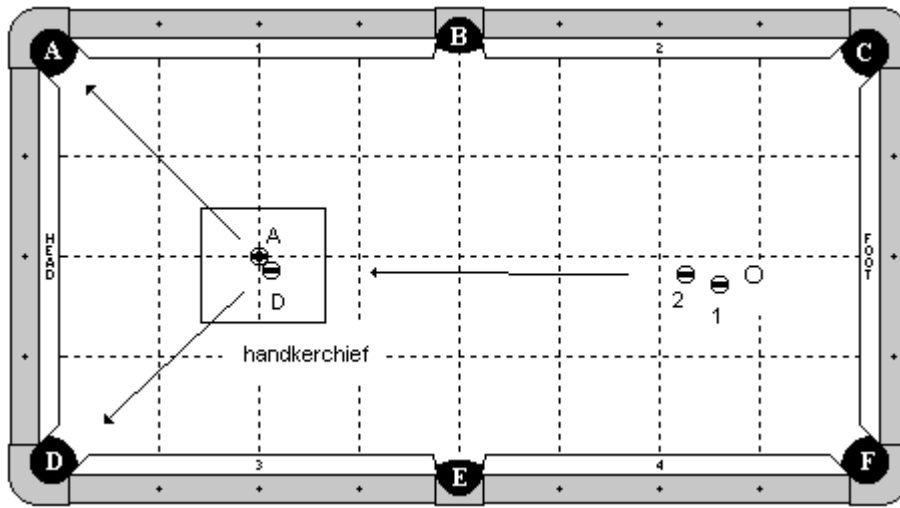

Category

Miscellaneous

Difficulty: 8

Cue Ball

In hand behind the foot string, exactly 4 ball's width from the 2 ball.

Object Ball

'A' ball is on the head spot. D ball is in hand frozen to the 'A' ball. The 2 ball is in hand behind the foot string, but must be 4 ball's width from the cue ball. The 1 ball is centered between the cue ball and 2 ball, and $\frac{1}{2}$ ball offset.

Props

An opaque handkerchief, no smaller than 21 inches on any side, is placed over the two object balls so the balls are approximately centered.

Objective

Shoot the cue ball into the 1 ball, causing those balls to split. The cue stick will follow through and hit the 2 ball on the handkerchief and into the D ball. A and D balls will go in corresponding pockets.

Special Notes

Player must use one continuous motion when shooting this shot. There may not be a pause in their stroke.

Shot 124

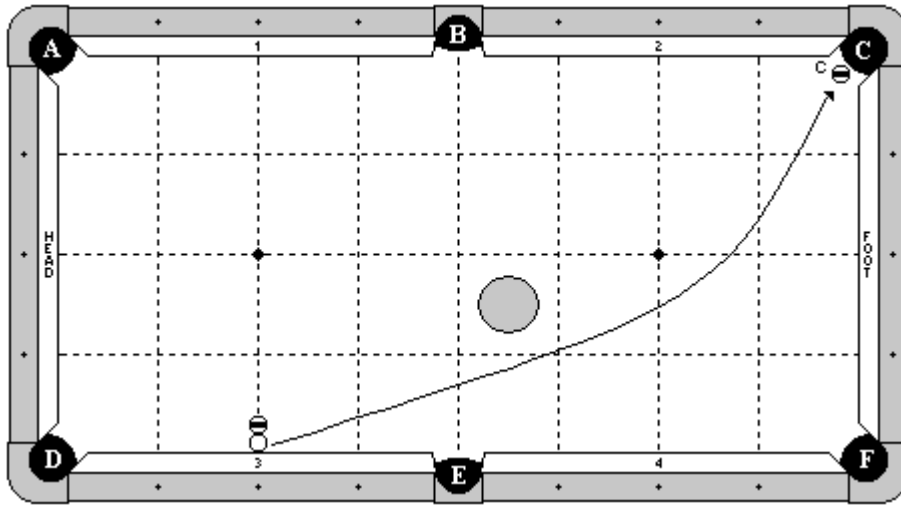

Category

Miscellaneous

Difficulty: 7

Cue Ball

Frozen to the cushion at the 2nd diamond.

Object Ball

A blocking ball is frozen to the cue ball along the 2nd diamond. C ball is hanging near pocket C.

Props

A piece of new chalk (well up) is placed in the center of the 1x1 zone, and a large Aramith ball is placed on top of it. The ball is 3 inches in diameter.

Objective

Shoot the cue ball into cushion 3. The cue ball will compress the rail and travel around the large ball, making C ball in pocket C.

Special Notes

The blocking ball may not be moved by any means until after C ball is made. The large ball may be contacted, but may not fall off the chalk, until after C ball is made.

Shot 125

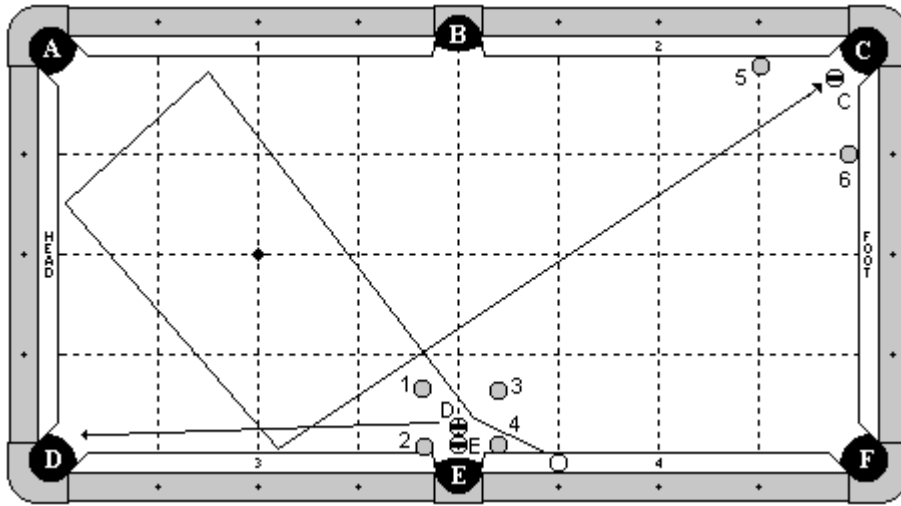

Category

Miscellaneous

Difficulty: 8

Cue Ball

In hand on top of cushion 4.

Object Ball

E and D balls are frozen and in hand near pocket E, but the back edge of E ball must be even with the pocket cut. C ball is hanging near pocket C.

Props

6 plastic champagne glasses, each with an object ball inside of it, are placed as diagrammed. Glasses 2 and 4 are wedged under the cushion, with the edge even with the pocket point. Glasses 1 and 3 are straight out and 2 ball's width from the other glasses (measured from the base). Glasses 5 and 6 are wedged up under the cushion at the 1st diamond.

Objective

Shoot the cue ball between glasses 3 and 4, into D ball. The cue ball will then go between glasses 1 and 3, 3 rails, and between glasses 5 and 6 to make C ball. D and E balls will go as pocket letter designates, with D ball going between glasses 1 and 2, and E ball going between glasses 2 and 4.

Special Notes

The glasses may not be hit or moved by any means until the cue ball has stopped rolling. The cue ball may hit an extra cushion near pocket C.

Shot 126

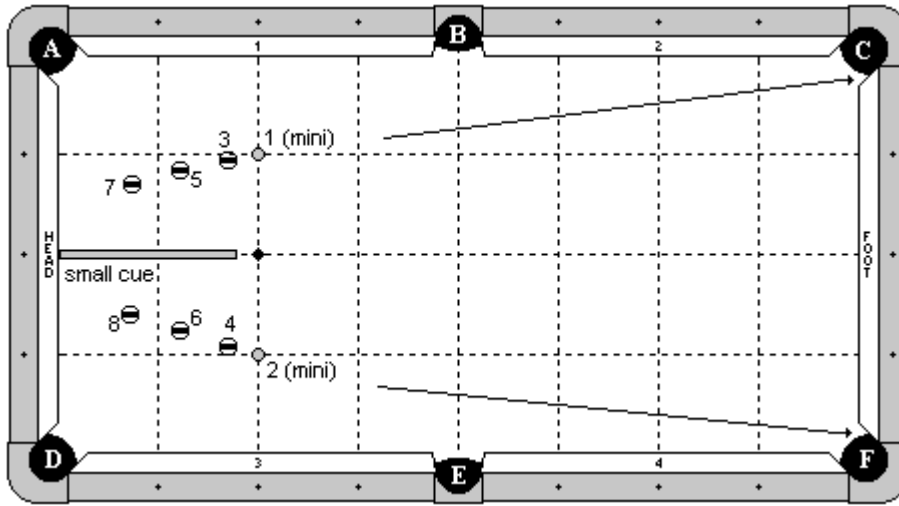

Category

Jump

Difficulty: 8

Cue Ball

None

Object Ball

3 ball is 1 ball's width from the mini pool ball. 5 ball is 2 ball's width from the 3 ball. 7 ball is 2 ball's width from the 5 ball. Balls 4,6,8 are setup in the mirror image.

Props

A mini 1 ball and 2 ball are on the head string, 1 diamond away from each cushion as diagrammed. A short mini cue is on the table along the head string, with the butt frozen to the cushion. Players may use any mini cue or jump cue.

Objective

Shoot all balls in reverse numerical order (8 through 1). The 7,5,3 will be jumped into pocket C, and the 8,6,4 will be jumped into pocket F. For the 2 and 1 balls, pickup the mini cue and shoot them straight into the pockets.

Special Notes

While shooting, no other ball may be disturbed by any means. When jumping, players must use a dart style stroke.

Shot 127

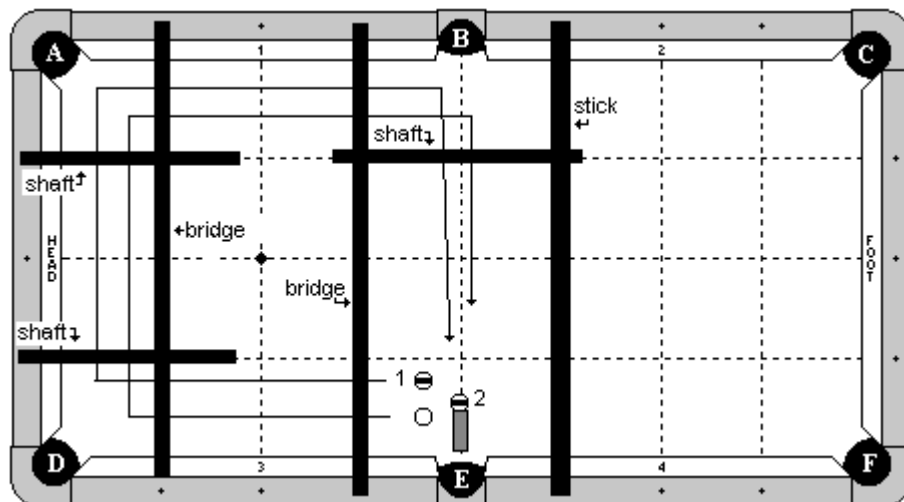

Category

Speed / Juggling

Difficulty: 10

Cue Ball

In hand within the 1x1 diamond zone to the left of pocket E.

Object Ball

1-ball in hand within the same zone as the cue ball. 2-ball on a coin wrapper near pocket E.

Props

A coin wrapper is under the 2 ball. A stick is on the rail tops on the 3rd diamond to the right of pocket E. 2 bridges are on the rails between pockets E and D. One bridge is at the 3rd diamond and the other is at 1 diamond. Both have their butt ends propped up by a piece of chalk. Two shafts are resting on the bridge and the head cushion, each at 1 diamond. A third shaft is on the bridge and stick, at 1 diamond. Small objects may be used to keep the shafts in place if necessary.

Objective

Shoot the 1 ball and then the cue ball towards pocket D. Reposition yourself and shoot them across towards pocket A. Reposition yourself and shoot them up table towards the side pocket. Reposition yourself and shoot them both towards pocket E. The 1 ball will go in pocket E (knocking the coin wrapper away and causing the 2 ball to fall), and the cue ball will make the 2 ball.

Special Notes

All hits must be done while the balls are moving (if the referee can't tell because it is too close, the shot is no good). Each time the player must hit the 1-ball before the cue ball, and the balls may never contact each other. Each time the player must hit the balls in their quadrant created by the rails and the suspended sticks. Near pocket D they must be hit before they hit the head rail. Near pocket A they must be hit before they hit cushion 1. Near pocket B they must be hit before they hit the stick. The balls may hit the rails they are traveling parallel to. This shot must be performed as diagrammed and described. This shot must be performed within 16 seconds. The first hit on the object ball will start the clock and the last hit on the cue ball will stop the clock. The sticks may not be contacted by any means (balls, player's cue, player's hand, or anything) until after the cue ball makes the 2 ball

Shot 128

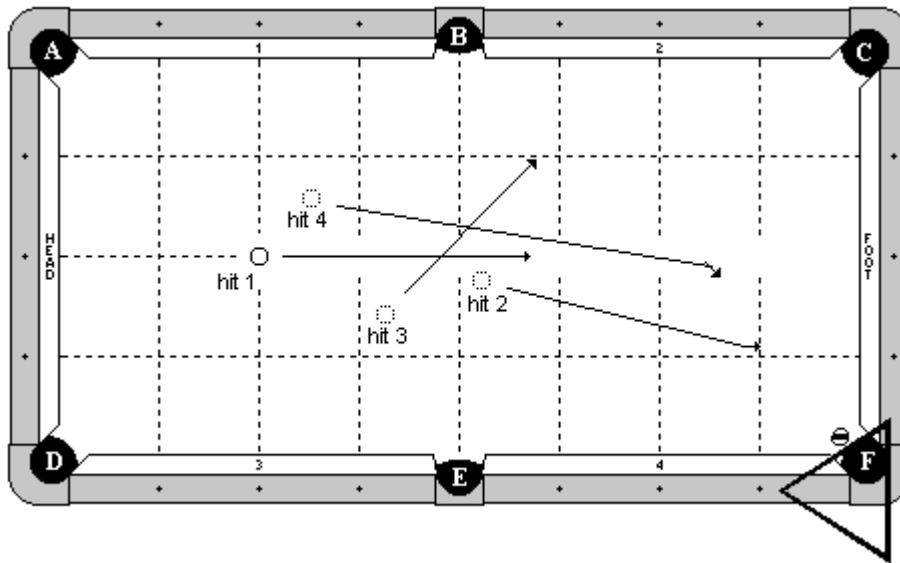

Category

Speed / Juggling

Difficulty: 10

Cue Ball

On the head spot.

Object Ball

Hanging near pocket F.

Props

A rack is on the rail top near pocket F and out of the way.

Objective

Shoot the cue ball 1 rail (foot cushion). Re-hit the cue ball 2 rails (foot, cushion 4). Re-hit the cue ball 3 rails (cushion 2, foot, cushion 4). Re-hit the cue ball 4 rails (foot, cushion 4, head, cushion 1). After re-hitting the cue ball for the last time (4 rails), walk over and pick up the rack, and place it down against the object ball. The cue ball will come around, hit the rack, and make the object ball.

Special Notes

The rails mentioned above are the only rails that may be hit and they must be the exact rails mentioned. For example, on the 3 rail shot, the cue ball must start with cushion 2, not cushion 1. The only exception to this rule is that the cue ball may contact an extra rail(s) near pocket F after it has hit the required 4 rails mentioned above. It is okay if the cue ball makes the object ball by going between the rack and the cushion. All hits on the cue ball must be while moving (close calls because the referee couldn't tell if it was moving will be no good). When positioning the rack, the object ball may be moved slightly, but it may not be made with the rack as your hand is positioning it. Your hand must be completely clear of the rack when the cue ball hits it (close calls will result in the shot being no good). The entire shot must be performed in 8 seconds. The first hit on the cue ball will start the clock. The last hit on the cue ball (sending it 4 rails) will stop the clock. Players may not switch hands while shooting this shot (if they start righty, they must continue righty). This shot must be performed as diagrammed and described.

Shot 129

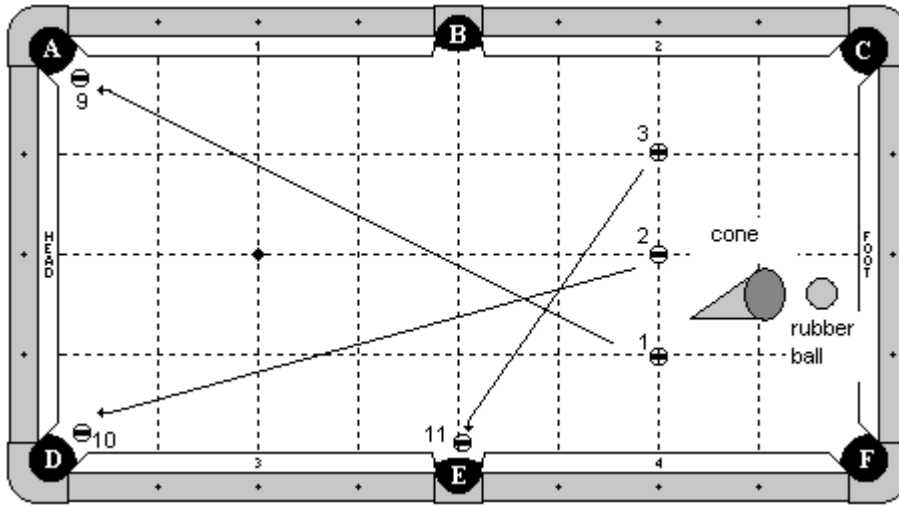

Category

Miscellaneous

Difficulty: 10

Cue Ball

None

Object Ball

The 1,2,3 balls are on the diamond intersection lines as diagrammed. The 9,10,11 are hanging near the pockets as diagrammed.

Props

A plastic cone is held by the player in one hand. Inside the cone is a rubber ball. Players are free to use their own cone and ball.

Objective

Squeeze the cone and turn it upside down. Loosen your grip and let the rubber ball fall and bounce. After it bounces, the player must hit the 1 ball 1-handed and make the 9 ball. Then the player must catch the ball in the cone. Repeat the same process and hit the 2 ball into the 10 ball, except this time the rubber ball must bounce twice before the player hits the 2 ball and catches the rubber ball. Repeat the same process and hit the 3 ball into the 11 ball, except this time the rubber ball must bounce 3 times before hitting the 3 ball and catching the rubber ball. This shot must be performed in 30 seconds or less. Time starts when the 1 ball is hit and time stops when the 3 ball is hit.

Special Notes

All hits on the 1,2,3 balls must be 1-handed. In all cases, the rubber ball must finish all of its required bounces BEFORE the 1,2,3 are hit. For example, on the 2 ball, the rubber ball must bounce twice, and then the player hits the 2 ball, and then the player catches the rubber ball in the cone. The player may not hit the 2 ball before the rubber ball has bounced twice, nor may the player hit the 2 ball after catching the rubber ball in the cone. The player may tap the cone with the cue stick in order to avoid the rubber ball getting stuck. The hand holding the cone must stay approximately level with their shoulder, but in no case may the hand go above the top of the player's head. The referee will be the

final judge. Fouls will only be called if the player is obviously raising his hand too high. Once object balls are hit, they may not interfere with the rest of the shot.

Shot 130

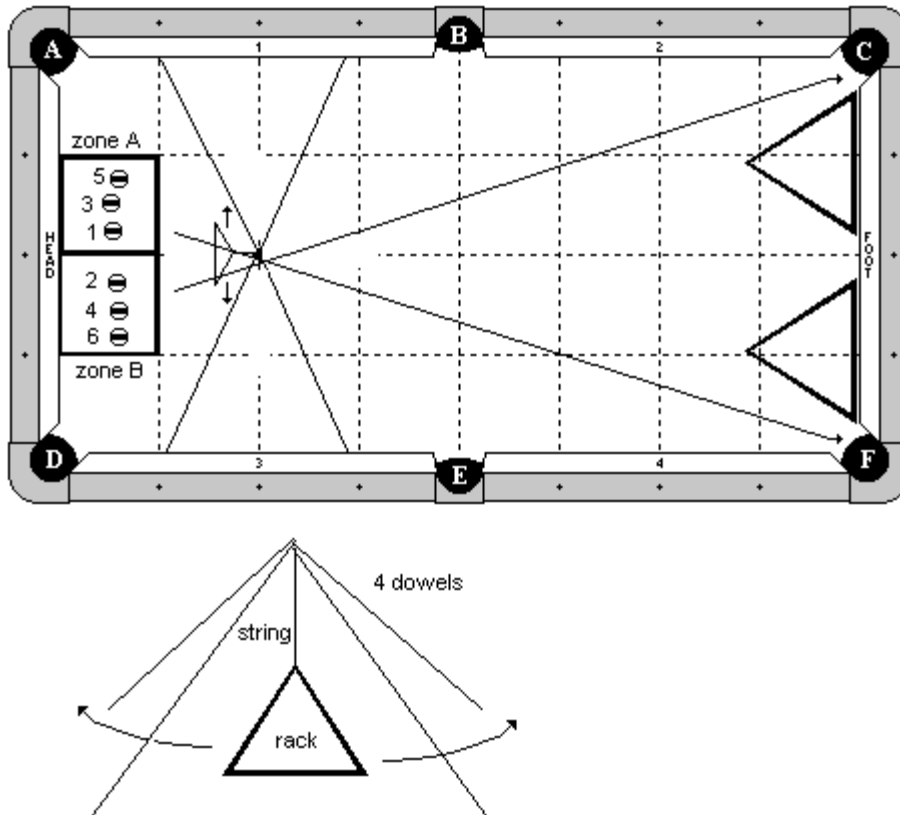

Category

Jump / Speed

Difficulty: 10

Cue Ball

None

Object Ball

The 1,3,5 are in hand in zone A. The 2,4,6 are in hand in zone B. The balls must be ordered as in the diagram, with the 1 and 2 balls closest to the center of the table, and the 5 and 6 furthest towards the outside.

Props

4 wooden dowels are propped up as diagrammed, forming a pyramid shape standing on the table. They are tied together with a string at the top that threads through holes drilled in each dowel. Another string will be wrapped through a normal rack and then wrapped around the top of the pyramid the suspend the rack. A domino (3/8 inches thick) and a chalk cube will be stacked on top of each other and used as a spacer to make sure the rack is high enough (the rack may not touch this spacer as it passes under it). The entire prop may be adjusted by the player, but the rack must hang within 1/2 diamond from the head string. Two additional racks are against the foot cushion as diagrammed, with optional weights inside them to support. The weights may be anything that does not interfere with the shot.

Objective

Player will pull the rack to the left so that the apex (center point where the string is looped around) is even with the side of the pyramid. Player will let go, causing it to swing back and forth. The rack will swing left to right (pass 1), right to left (pass 2), left to right (pass 3), and right to left (pass 4). It will continue swinging like this. On pass 4, the player will start jumping the balls in numerical order. The 1,3,5 will go into pocket F and the 2,4,6 will go into pocket C. The balls will all be jumped through the rack on every even pass. In other words, every time the rack goes from right to left, a ball must be jumped through it (except on pass 2 which is the first time it goes from right to left). Here is detailed explanation of when the balls will be jumped:

Pass 4: 1 ball

Pass 6: 2 ball

Pass 8: 3 ball

Pass 10: 4 ball

Pass 12: 5 ball

Pass 14: 6 ball

Special Notes

The swinging rack and the entire prop may not be touched by any means. Balls may touch the two racks down at the end of the table, but if they move, they must remain in their new position for the remainder of the shot. If the player decides to use weights inside the racks, those weights must be positioned in such a way that no object ball touches them and that they do not interfere with any part of the shot. Once the player lets go of the rack, the shot has started, and failure to complete the shot will result in no point. If a player fails to jump any object ball on its required pass of the rack, the shot is no good.

Shot 131

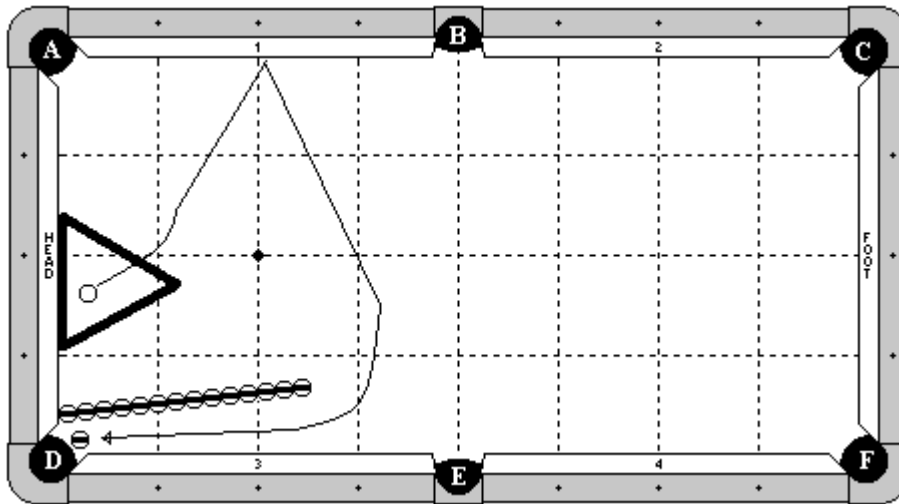

Category

Jump / Masse

Difficulty: 10

Cue Ball

In hand inside the rack.

Object Ball

An object ball is hanging near pocket D. A line of 14 blocking balls has the first ball frozen to the cushion with the edge at the pocket point. The other balls are frozen in a straight line, with the last ball no further out than 1 diamond off the long cushion.

Props

Rack frozen to the cushion, with the center of the rack not past the middle diamond.

Objective

Jump the cue ball out of the rack, along the indicated path, and make the object ball in pocket D.

Special Notes

The cue ball may hit the rack. The cue ball may hit any of the blocker balls, but the cue ball must make the object ball in pocket D. It may not be made by a combination because the blocker balls got in the way. The player must use silicone on the cue ball.

Shot 132

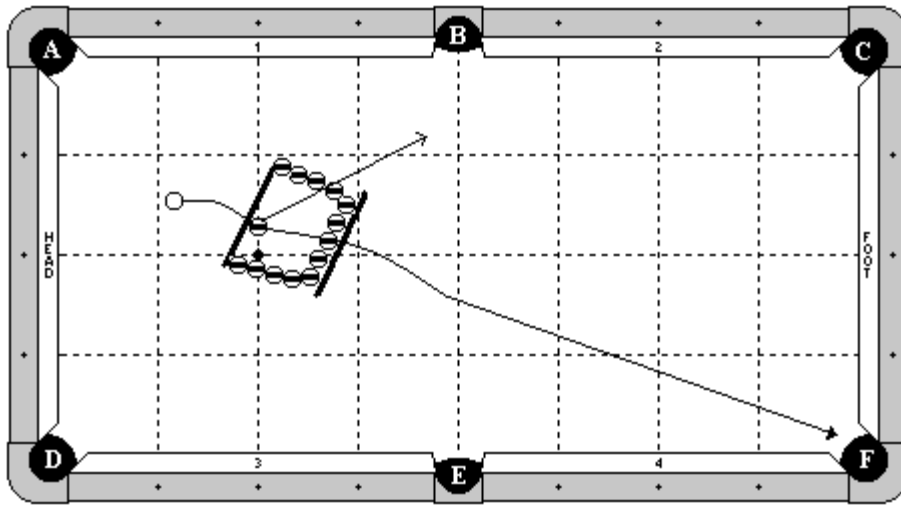

Category

Jump

Difficulty: 10

Cue Ball

In hand

Object Ball

Blocker balls as diagrammed, creating about a 5 ball gap between the racks, and about a 3 ball gap from left to right. An object ball is inside this setup as diagrammed. This entire setup is in hand.

Props

Two racks are standing upright as diagrammed.

Objective

Jump the cue ball through the first rack and into the object ball. The object ball will fly over the blocking balls and through the second rack, going into pocket F.

Special Notes

The racks and blocker balls may not be contacted by any means until after the object ball is made in pocket F.

Shot 133

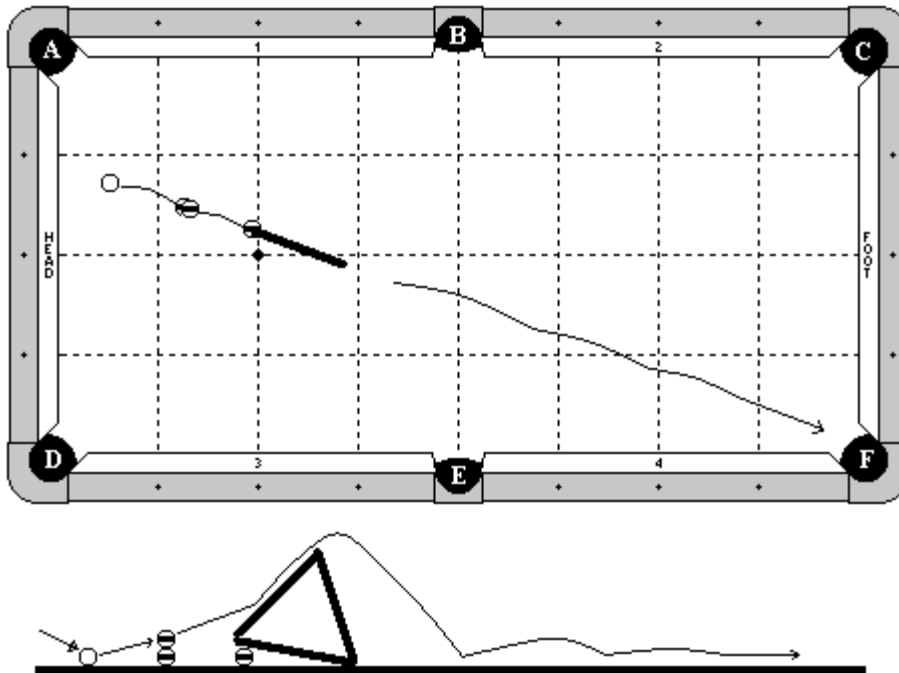

Category

Jump

Difficulty: 10

Cue Ball

In hand

Object Ball

1 ball is stacked on top of a special stacking ball. Another object ball is under the rack, propping it up as diagrammed.

Props

A rack is standing upright, balanced on top of an object ball. A special stacking ball is in hand. The rack is in hand, but part of the rack must cover the head string.

Objective

Jump the cue ball into the 1 ball (the top ball of the stack). The 1 ball will hit the rack, launch over it, and go into pocket F. The 1 ball must go over the apex of the rack. The referee will judge as to whether the ball went as high as the apex of the rack. If the 1 ball goes around the side of the rack, the shot is no good.

Special Notes

The cue ball, stacked balls and rack must be lined up towards pocket F.

Shot 134

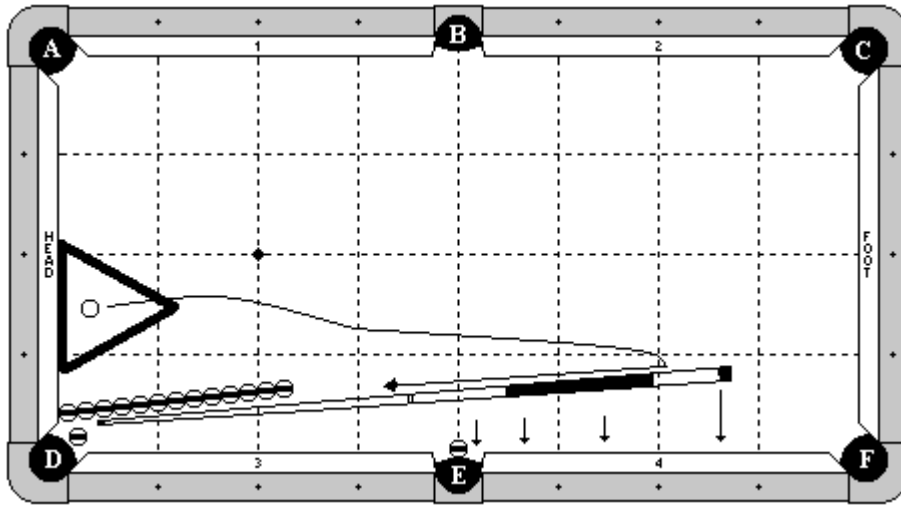

Category

Jump / Masse

Difficulty: 10

Cue Ball

In hand within the rack.

Object Ball

Two object balls are hanging near pockets E and D. A line of 13 blocker balls are diagrammed. The first ball is frozen to the cushion with the edge at the pocket point. The other balls are all frozen in a straight line, and may be adjusted provided that the last ball is no more than 1 diamond off the long rail.

Props

The rack is frozen to the cushion and adjustable, but the center of the rack may not go past the middle diamond. The cue stick is adjustable, but may not be more than $\frac{1}{2}$ ball's width away from the blocker balls.

Objective

Jump the cue ball out of the rack. The cue ball will hit the cue stick, causing it to roll towards the long rail and make the ball in pocket E. The cue ball will then masse back and make the object ball in pocket D.

Special Notes

The cue ball may hit the rack when jumping out of it. The cue ball may contact the blocker balls, but only on the way back towards pocket D. The cue ball must make the object ball in pocket D. It may not be made by a combination because the blocker balls got in the way. The player must use silicone on the cue ball.

Shot 135

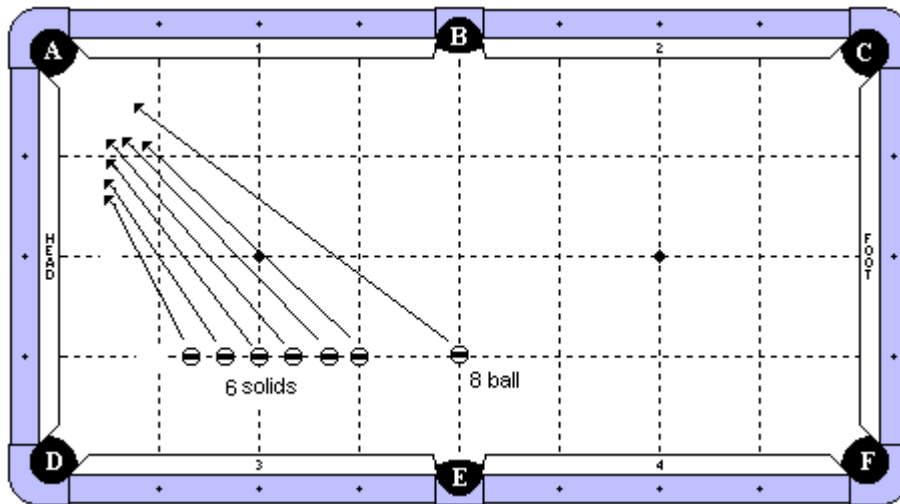

Category

Speed

Difficulty: 9

Cue Ball

None

Object Ball

The 8 ball is placed on the center line, 1 diamond segment away from pocket E. 6 object balls are placed along the 1st diamond line. All balls may be adjusted along this line, but the base of the balls must be between the 3rd diamond and the 1st diamond.

Props

None

Objective

Shoot the 8 ball towards pocket A. Quickly shoot the 6 balls into pocket A. All 6 balls must go in before the 8 ball.

Special Notes

None

Shot 136

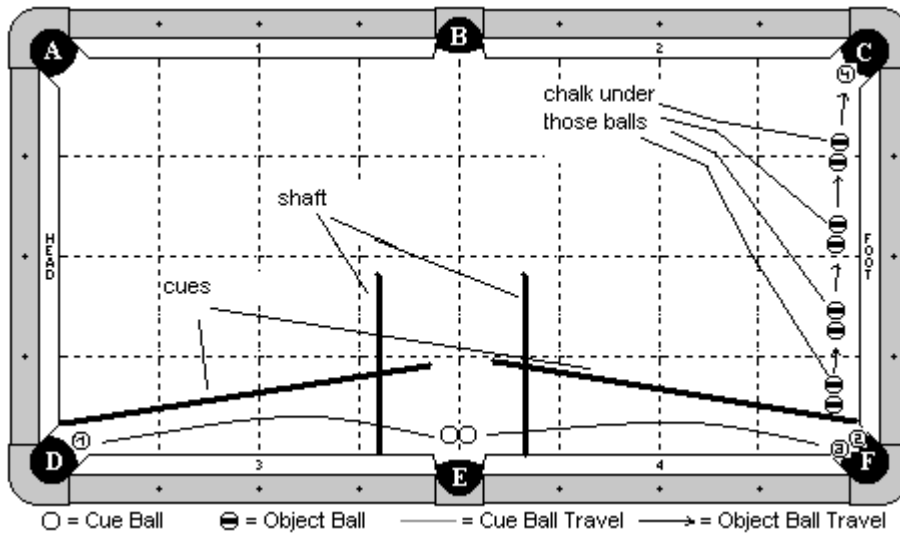

Category

Miscellaneous

Difficulty: 10

Cue Ball

Near pocket E. Cue balls are frozen.

Object Ball

1 ball near pocket D, 2 ball and 3 ball near pocket F, 4ball near pocket C.

Props

Two cues and shafts as diagrammed. The shafts are placed under the cues. Chalks under the balls as diagrammed.

Objective

Shoot between cue balls. One cue ball will jump over shaft and pocket 1 ball. Other cue ball will jump over 2nd shaft pocket 2 and 3 ball, make chain reaction and make 4 ball.

Special Notes

Cue balls can not touch shafts when jumping.

Shot 137

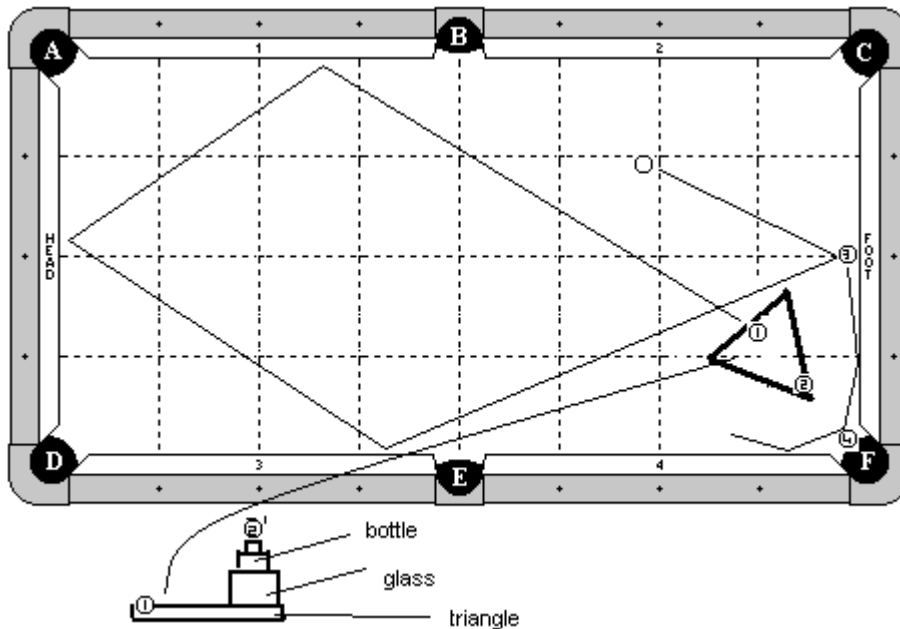

Category

Miscellaneous

Difficulty: 10

Cue Ball

In hand

Object Ball

3 ball frozen to the cushion. 4 ball near pocket F. 1 ball in the triangle. Chalk is placed under 1 ball. 2 ball is on the top of the bottle.

Props

Rack in hand. Chalk under the 1 ball. A glass and bottle are under the 2 ball as diagrammed.

Objective

Shoot cue ball into 3 ball. Cue ball will pocket 4 ball. 3 ball will hit 4 rails, hit triangle. 1 ball will fall of the chalk hit the glass. 2 ball will go to E pocket.

Special Notes

The 2 ball cannot touch the 4 ball. The cue ball may not hit the rack, until after the cue ball makes the 4 ball.

Shot 138

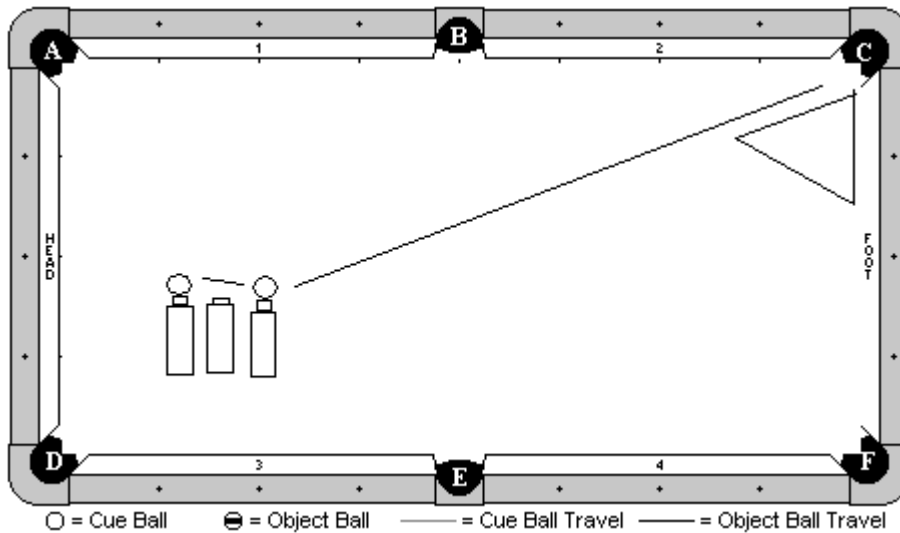

Category

Miscellaneous

Difficulty: 10

Cue Ball

On the top of the 1st bottle

Object Ball

On the top of the 3rd bottle

Props

Bottles in hand as diagrammed. Rack near pocket as diagrammed.

Objective

Shoot the cue ball into the object ball. The object ball will fly off the bottle and go into the pocket, optionally hitting the rack. The cue ball will remain balanced on the middle bottle.

Special Notes

Once the cue ball is hit, the referee will start a timer. The cue ball must spin for a minimum of 10 seconds. Once the timer reaches 10 seconds, the shot is over, but the cue ball must remain in motion (spinning) for those 10 seconds.

Shot 139

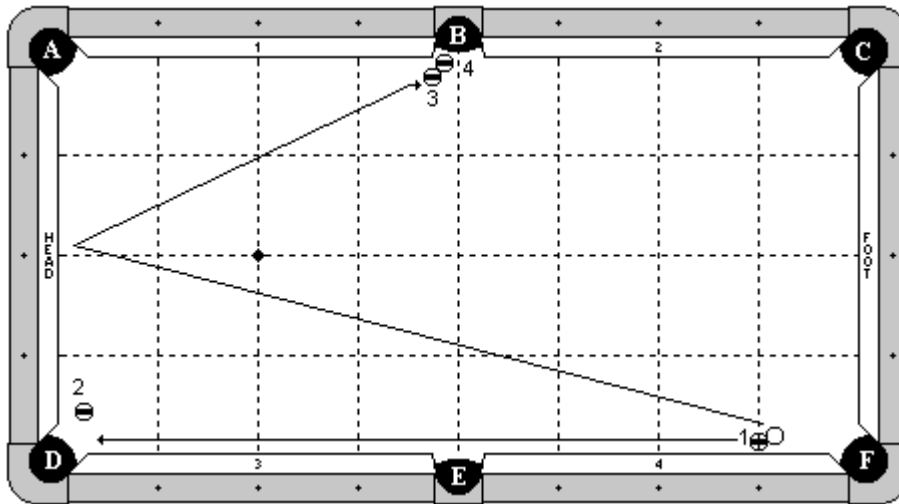

Category

Miscellaneous

Difficulty: 10

Cue Ball

On top of a chalk cube, frozen to the 1 ball and 1 inch off the cushion (the edge of the cue ball is 1 inch off the cushion).

Object Ball

1 ball frozen to the cushion at the 1st diamond. 2 ball is 1 ball's width off the head cushion and the edge is even with the pocket point. The 3 and 4 balls form a combination near pocket B.

Props

A chalk cube is under the cue ball.

Objective

Shoot the cue ball into the 1 ball. The 1 ball will go in pocket D. The cue ball will follow the indicated path and make the combination (4 ball) in pocket D.

Special Notes

The chalk cube may not fall over and it must remain in its original position until after the 1 and 4 balls have been made. The 2 ball may not be hit by any means until the 1 and 4 balls have been made. The cue ball may contact an extra cushion near pocket B.

Shot 140

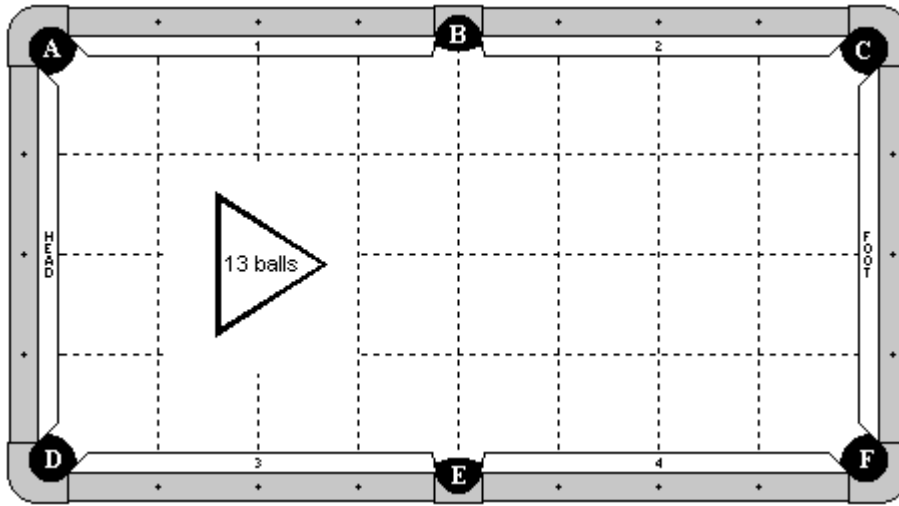

Category

Jump

Difficulty: 10

Cue Ball

None

Object Ball

13 object balls are inside a rack.

Props

A rack is in hand anywhere on the table. If you measure the inside distance from the point to the back edge, it is $10 \frac{5}{16}$ inches. The rack is $1 \frac{1}{4}$ inches tall. Players may use their own rack provided that it does not exceed these dimensions. I use a plastic Bush Beer rack.

Objective

Jump all 13 balls (one at a time) into any pocket(s). The player may shoot any ball into any pocket and does not need to shoot them all in the same pocket, nor does he have to go in any order or shoot a certain number in each pocket, or use all of the pockets. The player will continue shooting while balls are made and the shot will only count if all 13 balls have been made.

Special Notes

The rack / balls may be hit while jumping, causing them to move. However, if this happens, the rest of the shot must be performed from that position, unless the rack / balls are moved again while jumping. The player may not intentionally reposition any of the balls or the rack during the shot.

Shot 141

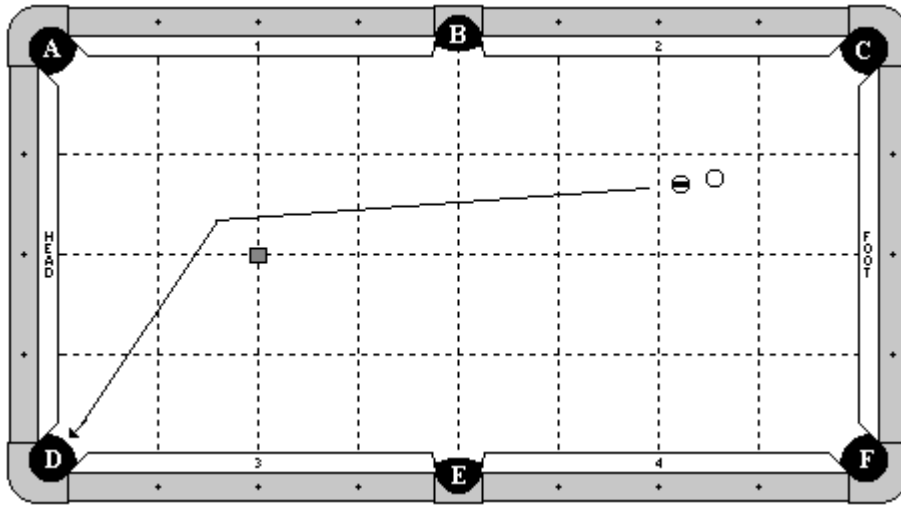

Category

Wing

Difficulty: 10

Cue Ball

Starts in your hand as in a standard wing shot.

Object Ball

Starts in your hand as in a standard wing shot.

Props

A chalk cube is on the head spot as in a standard wing shot from the Artistic Pool program.

Objective

Roll the object ball down the table, position the cue ball behind the head string, and execute a standard wing shot, making the object ball in pocket D. Before the player shoots the cue ball to make the wing shot, the player must turn their head completely away so he cannot see any of the balls.

Special Notes

The referee will be the final judge on all aspects of this shot. As in a standard wing shot from the Artistic Pool program, the object ball must pass between the chalk and the head cushion on its way to pocket D, and the chalk may not be hit by the object ball.

Shot 142

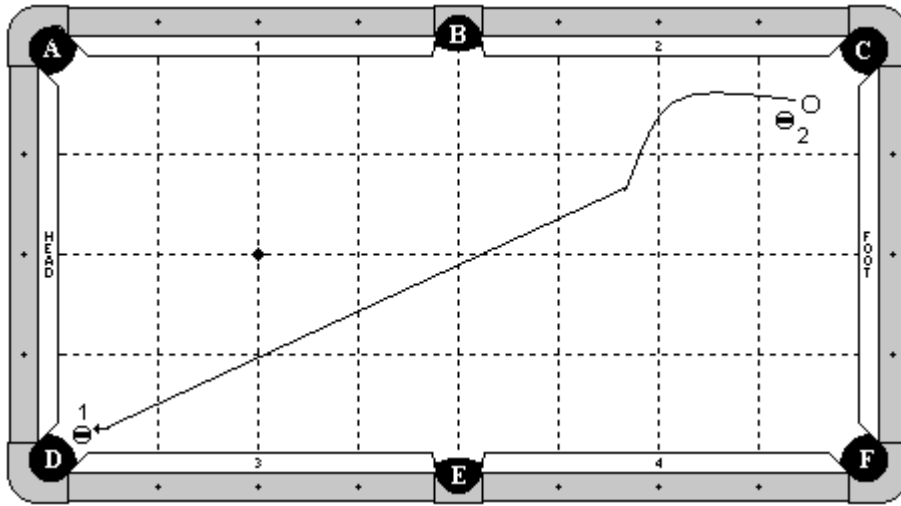

Category

Jump

Difficulty: 9

Cue Ball

In hand within the 1x1 diamond zone near pocket C, and exactly 1 chalk's width from the 2 ball.

Object Ball

In hand within the 1x1 zone near pocket C, and exactly 1 chalk's width from the cue ball. The 1 ball is hanging near pocket D. All 3 balls must be in a straight line.

Props

None

Objective

Jump the cue ball over the 2 ball and make the 1 ball.

Special Notes

The 2 ball may not be touched by any means until after the 1 ball is made.

Shot 143

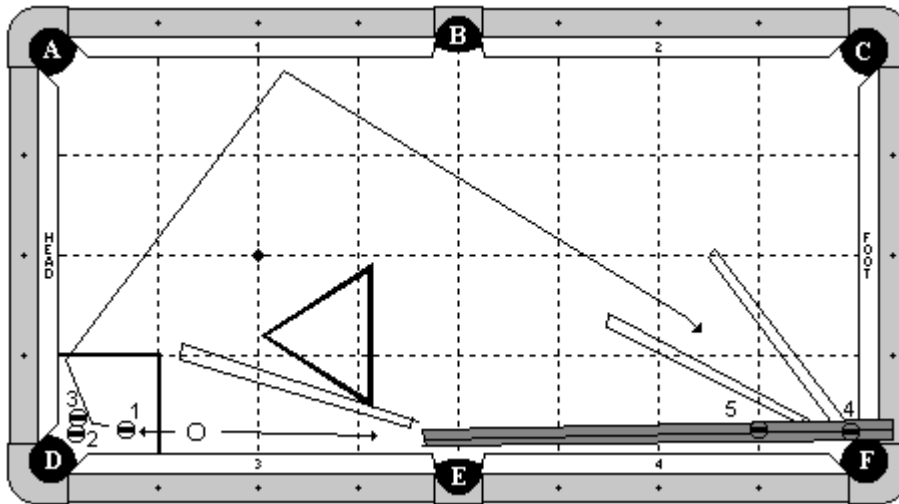

Category

Stroke

Difficulty: 10

Cue Ball

In hand behind the 1st diamond line from pocket D.

Object Ball

The 3 ball is balanced on top of a the 2 ball, which is a special stacking ball. The 1 ball is in hand within the 1x1 zone. The 5 ball is balanced on top of the two cues at the 1st diamond. The 4 ball is balanced near the end of the 2 cues and is adjustable. A piece of tape (no more than 1 inch wide) is attached to the 4 ball and hanging down into the pocket, and attached to the slate or wherever it is possible depending on the table.

Props

Two normal length cues are laying on the table as diagrammed, with their butt ends on top of the short rail, and propped up on chalk. These are special cues that are attached. Players may use their own cues and attach them in any manner. Another two normal length cues are in hand with their shaft ends inside pocket F. A shaft is in hand to be used as a guide for the cue ball and a rack is against that shaft for support.

Objective

Shoot the cue ball into the 1 ball. The 1 ball will hit the 2 ball (stacking ball) and make it in pocket D, causing the 3 ball to fall down and stay near the pocket. The 1 ball will bank off of the head cushion and cushion 1, into the opening created by the 2 cues, and go into pocket F, also causing the 4 ball to fall into pocket F. The cue ball will draw up the 2 cues, hitting the 5 ball, causing it to dislodge. The cue ball will roll down the cues, make the 3 ball and get out of the way, allowing the 5 ball to also roll down the cues and go into pocket D.

Special Notes

You must use a draw stroke, not a masse stroke. I will use special flashing balls for the 1,3,4,5 balls, but the player may use normal object balls if they want. The ramp cues are adjustable, provided that the 5 ball is at the 1st diamond. Players may use a small piece of paper (or anything) to keep the 4 and 5 in place. The cue ball may not scratch in pocket D.

Shot 144

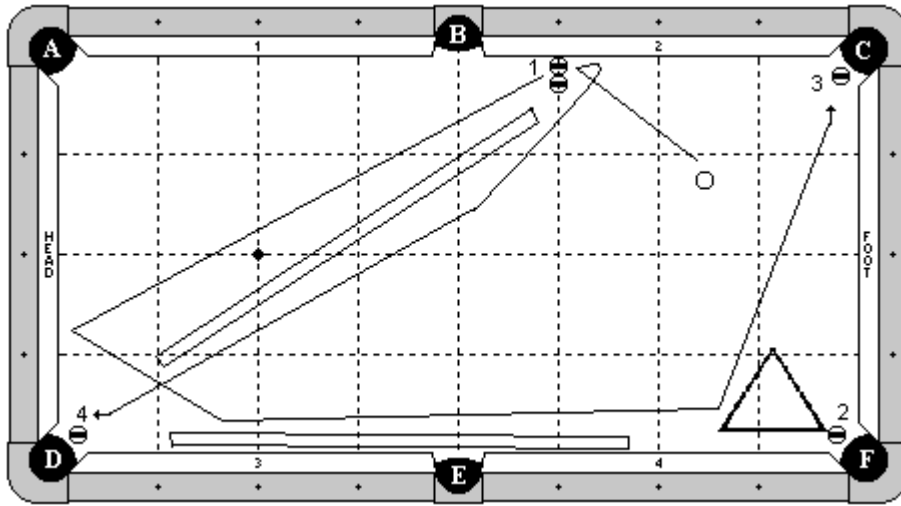

Category

Stroke

Difficulty: 10

Cue Ball

In hand behind the foot string.

Object Ball

1 ball is frozen to the cushion at the 3rd diamond. A blocking ball is frozen to the 1 ball, also along the 3rd diamond. The 2,3,4 balls are all hanging near their respective pockets as diagrammed.

Props

Two cues are on the table as diagrammed. One cue is against the long cushion and the other is aligned from the blocking ball to pocket D. A rack is in hand as diagrammed, frozen to the 2 ball.

Objective

Shoot the cue ball into the 1 ball. The 1 ball will travel 2 cushions as diagrammed, hit the cue against the long cushion, come down and hit the rack, making the 2 ball, then travel off the rack and make the 3 ball. The cue ball will curve around the blocking ball, hit the other cue stick, and make the 4 ball.

Special Notes

The cue ball doesn't have to hit the diagonal cue stick. It may go directly into the 4 ball. The blocking ball may not be touched by any means until after all balls have been made. The cue ball may not contact the stick along the cushion until the 4 ball is made.

Shot 145

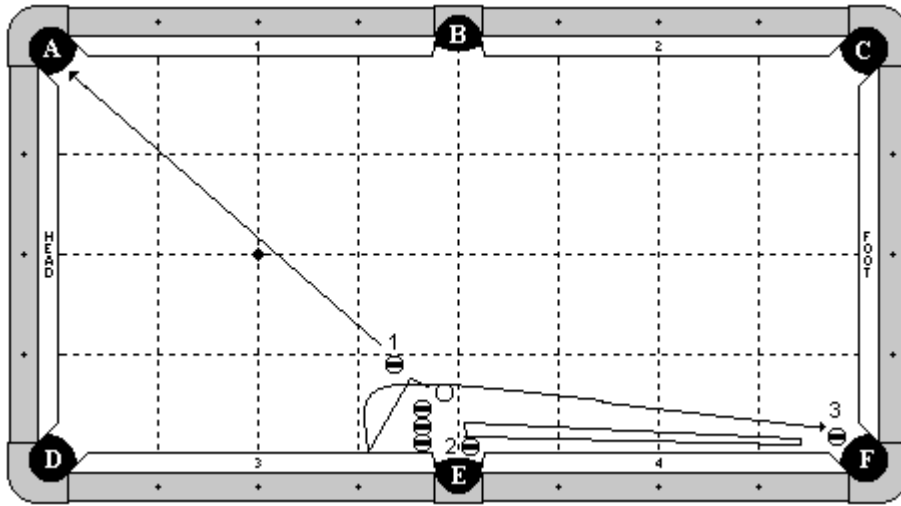

Category

Stroke

Difficulty: 10

Cue Ball

In hand, to the right of the 3 blocking balls (measured by the edge).

Object Ball

The 1 ball is in hand to the left of the 3 blocking balls (measured by the edge). The 2 ball is hanging near pocket E, and the 3 ball is hanging near pocket F. 3 blocking balls are frozen in line straight out from the rail, with their right edge all even with the pocket point.

Props

A masse cue is as diagrammed, with the butt end frozen to the 2 ball and the shaft end near pocket F.

Objective

Shoot the cue ball into the 1 ball, making it in pocket A. The cue ball will hit the long cushion, draw around the 3 blocking balls, hit the cue stick, and roll down making the 3 ball. When the cue ball hits the cue stick, the stick will make the 2 ball.

Special Notes

The blocking balls may not be touched by any means until after all balls have been made. A cue ball with silicone spray will be used for this shot.

Shot 146

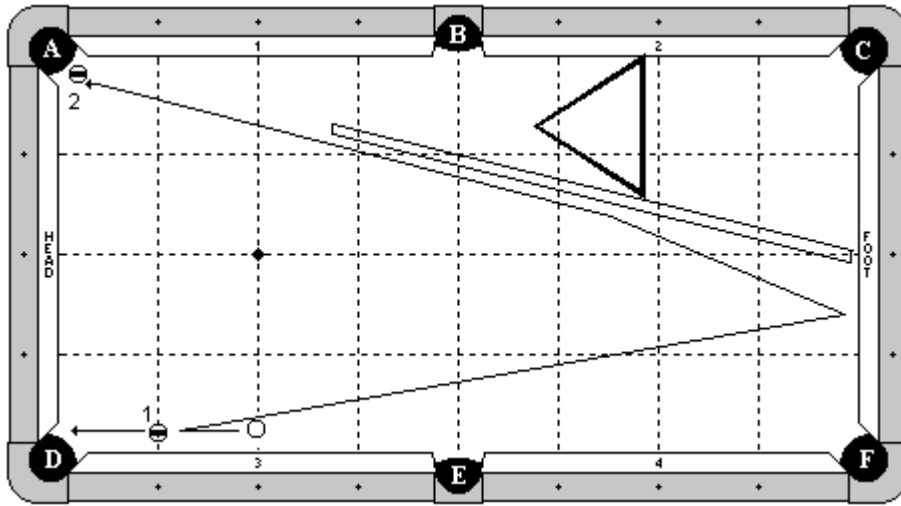

Category

Stroke

Difficulty: 10

Cue Ball

In hand, at least 1 diamond away from the 1 ball (measured by the base of the ball).

Object Ball

1 ball is along the 1st diamond, no more than 1 ball's width off the cushion. The 2 ball is hanging near pocket A.

Props

A cue stick (normal or short) is aligned from the 2nd diamond to pocket A. A rack may be used to stabilize the cue stick.

Objective

Shoot the cue ball into the 1 ball, making it in pocket D. The cue ball will draw back, hit the foot cushion, hit the cue stick, and make the 2 ball in pocket A.

Special Notes

The player must use a draw stroke, not a masse stroke. The cue ball does not have to hit the cue stick.

Shot 147

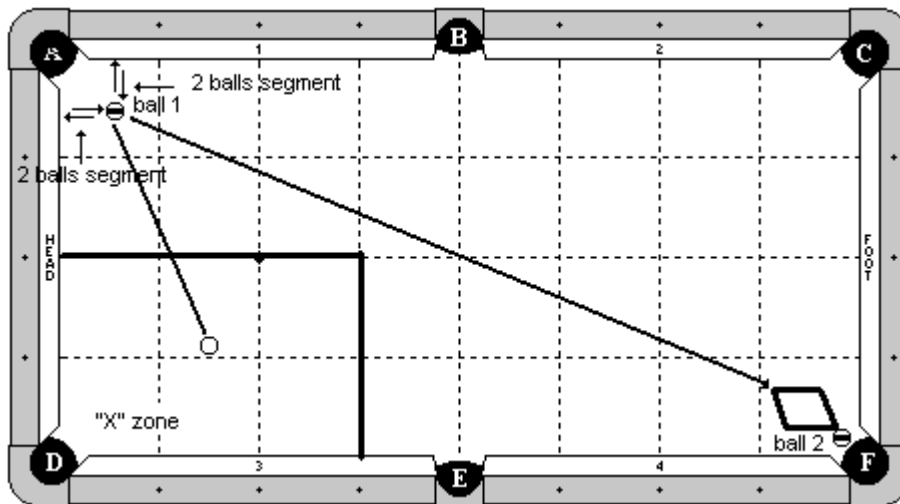

Category

Miscellaneous

Difficulty: 10

Cue Ball

In hand within 'X' zone.

Object Ball

1 ball is 2 ball's width from cushion 1 and 2 ball's width from the head cushion. 2 ball is hanging near pocket F.

Props

9 ball rack is frozen to 2 ball as diagrammed.

Objective

Shoot the cue ball into the 1 ball. The 1 ball will hit cushion 1 and the cue ball will hit the head cushion. As the cue ball and 1 ball come back off their cushions, the cue ball will hit the 1 ball again, causing it to travel down the table as diagrammed, hit the 9 ball rack, and make the 2 ball.

Special Notes

The cue ball may not contact cushion 1 before hitting the 1 ball for the second time. The 1 ball may contact only the foot cushion and cushion 4 before hitting the rack.

Shot 148

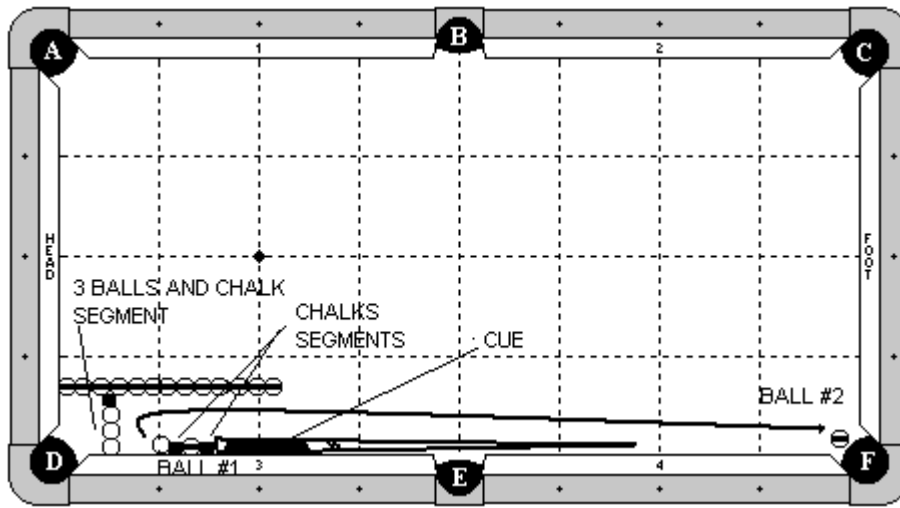

Category

Masse

Difficulty: 10

Cue Ball

Frozen to cushion 3 at the 1st diamond as diagrammed.

Object Ball

1 ball is frozen to cushion 3 and 1 chalk's distance from the cue ball. 2 ball is hanging near pocket F. A row of 13 balls is placed exactly 3 ball's width + 1 chalk's width from cushion 3. The first ball in this line is frozen to the head cushion and all of the balls are frozen in a straight line after that. Three spacer balls and a piece of chalk are drawn into the diagram to indicate this gap (these balls and chalk are not on the table when shooting the shot).

Props

A cue stick is on the table as diagrammed. The butt end of the stick starts 1 chalk's width from the 1 ball.

Objective

Masse the cue ball along the indicated path, making the 2 ball in pocket F.

Special Notes

The cue ball may not touch the 1 ball nor any of the 13 balls in line until after the 2 ball is made. The cue ball may contact the cue stick.

Shot 149

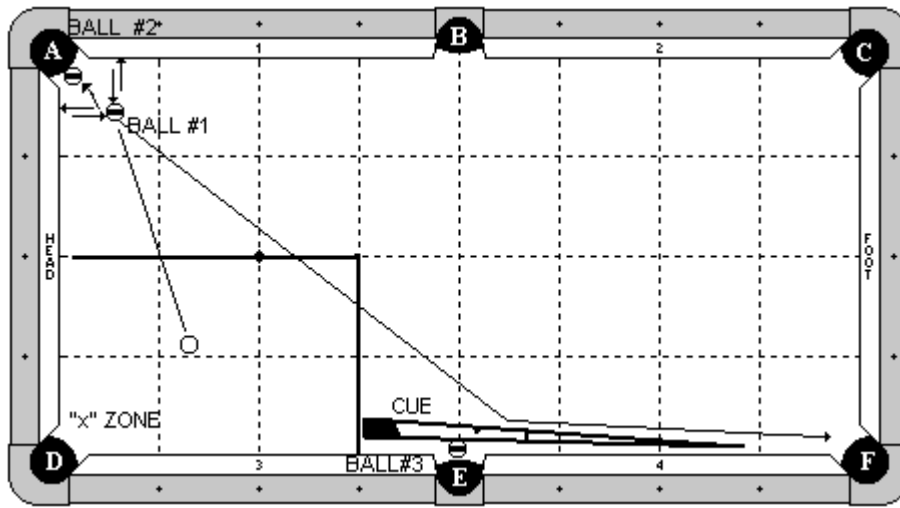

Category

Miscellaneous

Difficulty: 10

Cue Ball

In hand within the 'X' zone.

Object Ball

1 ball is two ball's width from cushion 1 and two ball's width from the head cushion as diagrammed. The 2 ball is hanging near pocket A, and the 3 ball is hanging near pocket E.

Props

A cue stick is in hand, frozen to the 3 ball, as diagrammed.

Objective

Shoot the cue ball into the 1 ball. The 1 ball will hit cushion 1 and the cue ball will hit the head cushion. As the balls come back from their cushions, the cue ball will hit the 1 ball again, causing it to travel along the indicated path, hitting the cue stick which will make the 3 ball, and then travel down the cue and go into pocket F. After the cue ball hits the 1 ball for the second time, it will then travel into the 2 ball, making it in pocket A.

Special Notes

The cue ball may only contact the head cushion until it hits the 1 ball for the second time. The cue ball may hit an extra cushion after hitting the 1 ball a second time, before it makes the 2 ball.

Shot 150

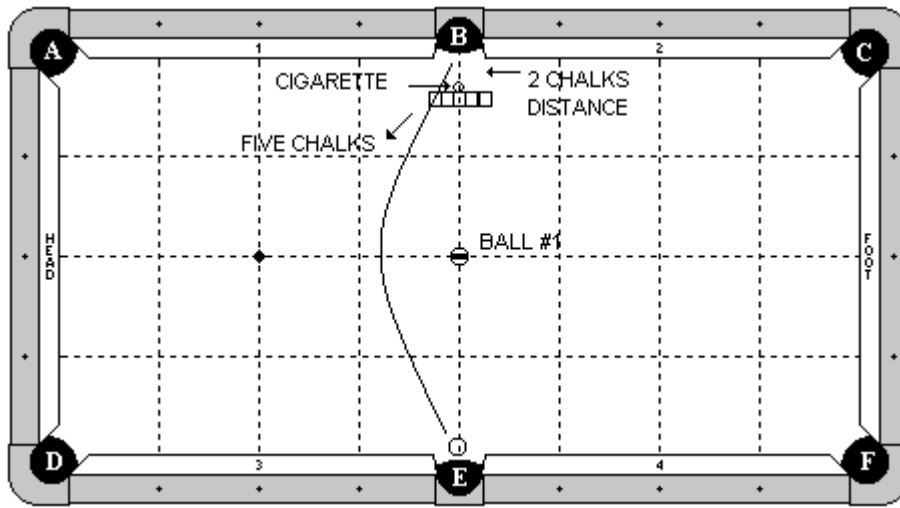

Category

Jump

Difficulty: 10

Cue Ball

Hanging near pocket E as diagrammed.

Object Ball

1 ball is on the center spot of the table.

Props

A line of five pieces of chalk are placed exactly two chalk's width from the edge of pocket B. All chalks are frozen to each other in line as diagrammed. A cigarette is standing up on the table, frozen to the center chalk as diagrammed.

Objective

Jump the cue ball over the 1 ball and over the chalks. The cue ball will knock down the cigarette and go into pocket B.

Special Notes

The cue ball may not contact the 1 ball nor the chalks by any means.

Shot 151

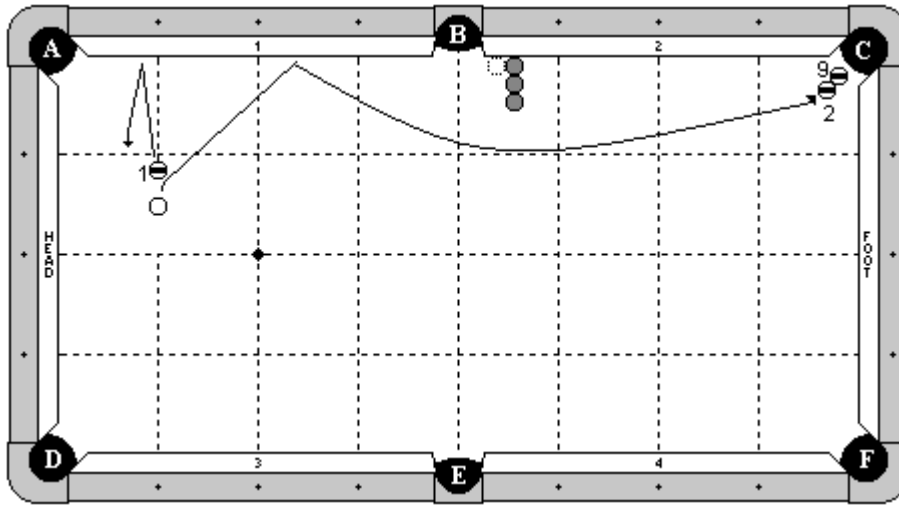

Category

Stroke

Difficulty: 10

Cue Ball

1 diamond off the head cushion, and 1 ½ diamonds off cushion 1.

Object Ball

1 ball is on the 1st diamond line, exactly 1 ball's width from the cue ball. The 2 and 9 balls form a combination near pocket C.

Props

Three bottles, no smaller in diameter than a ball's width, are as diagrammed. The first bottle is frozen to the cushion and 1 ball's width from the pocket point. The line of bottles are frozen and straight out from the cushion.

Objective

Force follow the cue ball to the 1 ball, the to the long rail. It will then curve around the bottles, and make the 9 ball.

Special Notes

The player must use silicone on the cue ball for this shot. The cue ball may not contact the bottles until after the 9 ball is made.

Shot 152

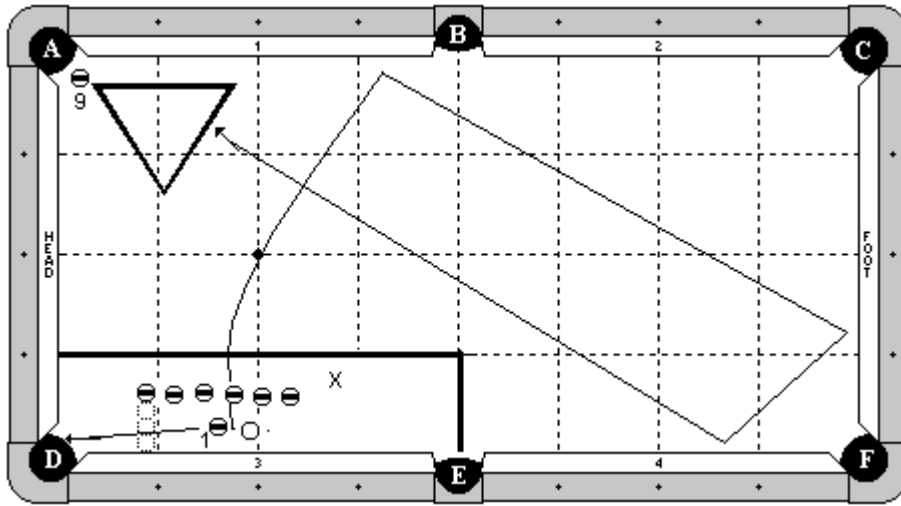

Category

Jump / Masse

Difficulty: 10

Cue Ball

In hand within zone X

Object Ball

1 ball no more than 1 inch from cue ball. 9 ball near pocket A. 6 blocker balls, exactly 3 ball's width from cushion 3.

Props

Rack frozen to 9 ball.

Objective

Shoot cue ball into 1 ball, causing it to go into pocket D. The cue ball will jump over the line of balls without touching them, hit cushions 1, foot, and 4, and then hit the rack and make the 9 ball.

Special Notes

Shot 153

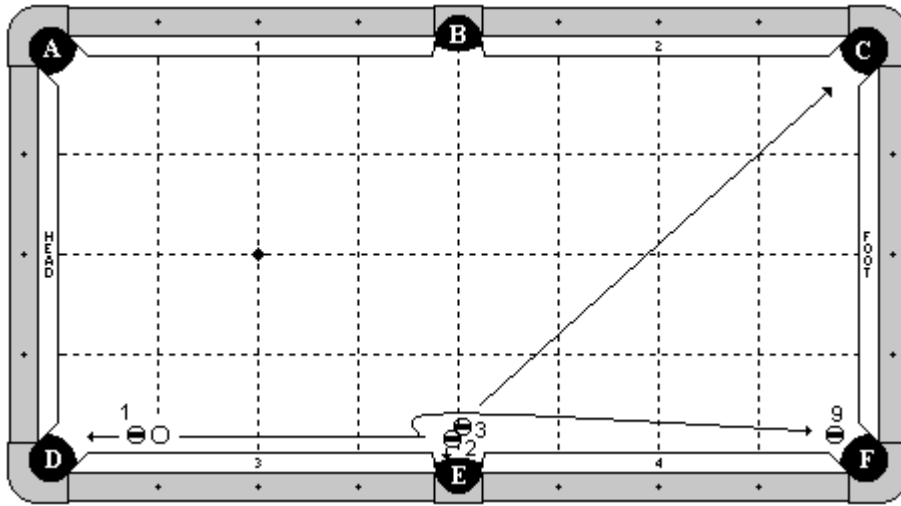

Category

Masse

Difficulty: 10

Cue Ball

In hand along the 1st diamond.

Object Ball

1 ball is no less than ¼ inch from the cue ball. 2 and 3 balls in hand near pocket E. 9 ball hanging near pocket F.

Props

None

Objective

Masse the cue ball to make the 1 ball in pocket D. The cue ball will spin back to make the 2 ball in pocket E and the 3 ball in pocket C. The cue ball will keep spinning towards the 9 ball, making it in pocket F.

Special Notes

The players must use silicone on the cue ball.

Shot 154

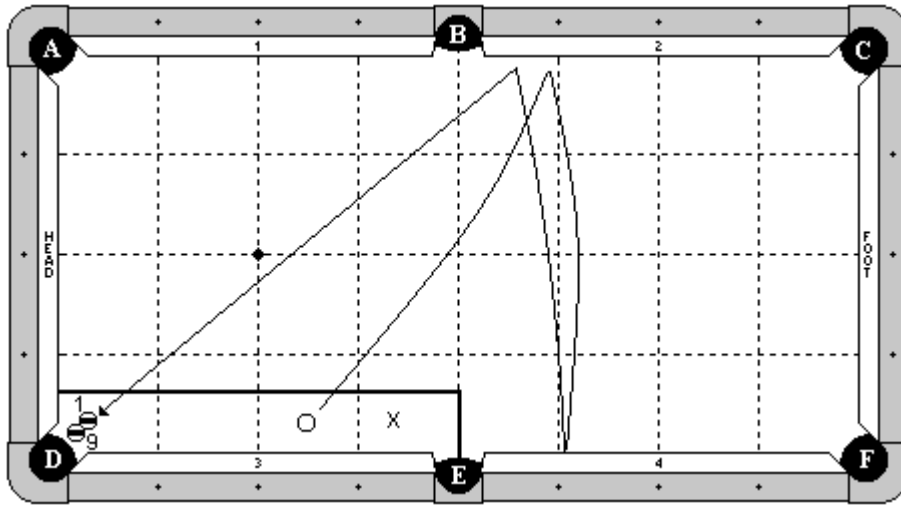

Category

Masse

Difficulty: 10

Cue Ball

In hand within zone X.

Object Ball

1-9 combination near pocket D.

Props

None

Objective

Masse the cue ball. It will hit cushion 2, then cushion 4, then cushion 2 again. It will then spin back, hitting the 1 ball and making the 9 ball.

Special Notes

The cue ball may catch an extra cushion near pocket D (head or 3). The players must use silicone on the cue ball.

Shot 155

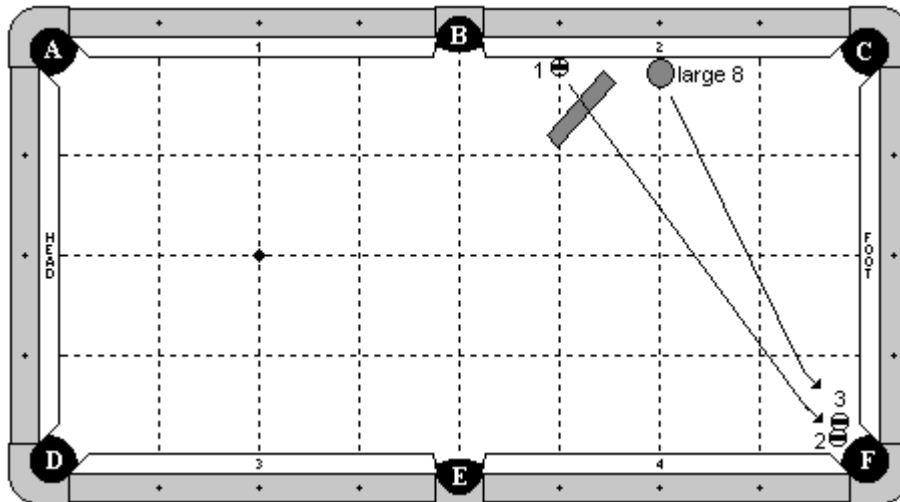

Category

Speed / Jump

Difficulty: 9

Cue Ball

None

Object Ball

1 ball frozen to cushion 2 at the 3rd diamond. Large 8 ball (3 inch diameter) frozen to cushion 2 at the 2nd diamond. A special stacking ball (2 ball) is hanging near pocket F. The 3 ball is balanced on top of the 2 ball.

Props

Special stacking ball and large 8 ball as described above. A rack is standing upright as diagrammed and must be at least 1 inch off cushion 2.

Objective

Shoot the large 8 ball towards pocket F. Quickly jump the 1 ball through the rack and make the 2 ball in pocket F. The 1 ball will get out of the way. The large 8 ball will then make the 3 ball in pocket F.

Special Notes

The rack may be hit, but it may not fall over by any means until after the shot is over. The large 8 ball must make the 3 ball without any interference by the 2 ball or 1 ball.

Shot 156

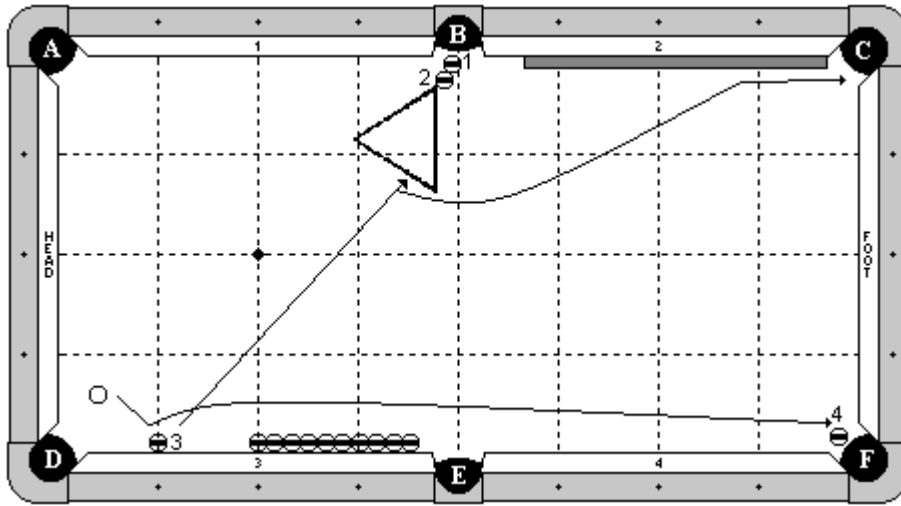

Category

Miscellaneous

Difficulty: 10

Cue Ball

In hand

Object Ball

1 and 2 balls form a combination near pocket B (both balls are frozen to each other). 3 ball is frozen to the cushion at the 1st diamond. 4 ball is hanging near pocket F. 10 blocker balls are propped up inside small medicine or Dixie cups as diagrammed.

Props

A rack is in hand with the apex frozen to the 2 ball as diagrammed. A cue (in part or whole) is along cushion 2. 10 small Dixie cups are under the 10 blocker balls. The cups are frozen to the cushion and the tops are 1 3/4 inch and the bottoms are 1 1/8 inch.

Objective

Shoot the cue ball into the 3 ball. The cue ball will follow around the blocket balls without hitting them and make the 4 ball. The 3 ball will bank into the rack, making both the 1 and 2 balls. The 3 ball will then go into pocket C as diagrammed.

Special Notes

The row of blocking balls may not be hit by any means until after all balls have been made. The 3 ball may hit the cue stick on the way to pocket C, but this is not required.

Shot 157

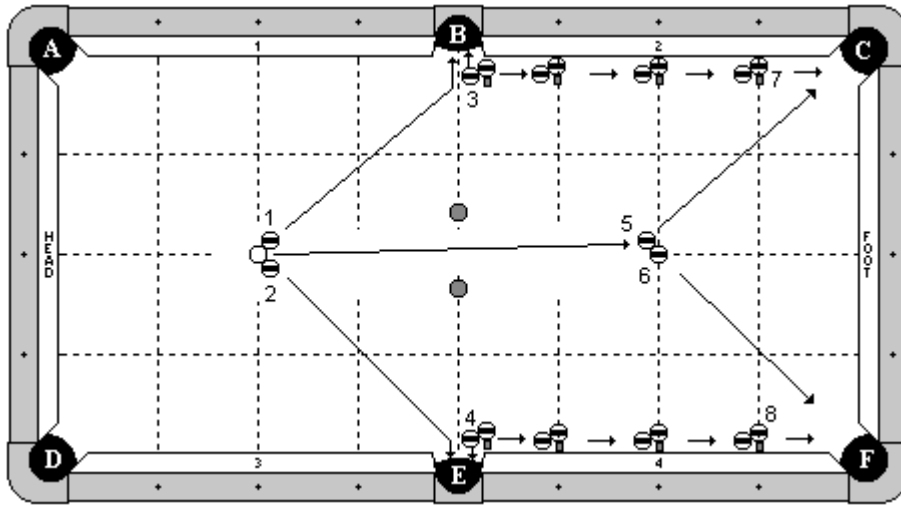

Category

Miscellaneous

Difficulty: 9

Cue Ball

In hand, frozen to the 1 and 2 balls.

Object Ball

1 and 2 balls in hand frozen to the cue ball. 3 and 4 balls in hand, frozen as diagrammed and frozen to the ball on the chalk that is next to it. 5 and 6 balls frozen to each other, with the 6 ball on the foot spot. 7 and 8 balls on top of chalks. Other balls complete the chain reaction, with every other ball on top of a piece of chalk, as diagrammed.

Props

Chalk cubes (player may place them however they want) are under every other ball in each line as diagrammed. Two plastic champagne glasses, with an object ball in each, are in hand along the center line of the table, but may be no more than 3 ball's width apart (measured at the base).

Objective

Shoot the cue ball towards the 5 and 6 balls. The 1 and 3 will go into pocket B. The 2 and 4 will go into pocket E. The 5 and 6 will go in pockets C and F respectively. The chain reaction will start the balls falling, eventually making both the 7 and 8 balls in pockets C and F.

Special Notes

The cue ball may not hit any ball other than those already described until after the 1,2,3,4,5,6,7,8 balls have been made. The cue ball must be shot between the glasses.

Shot 158

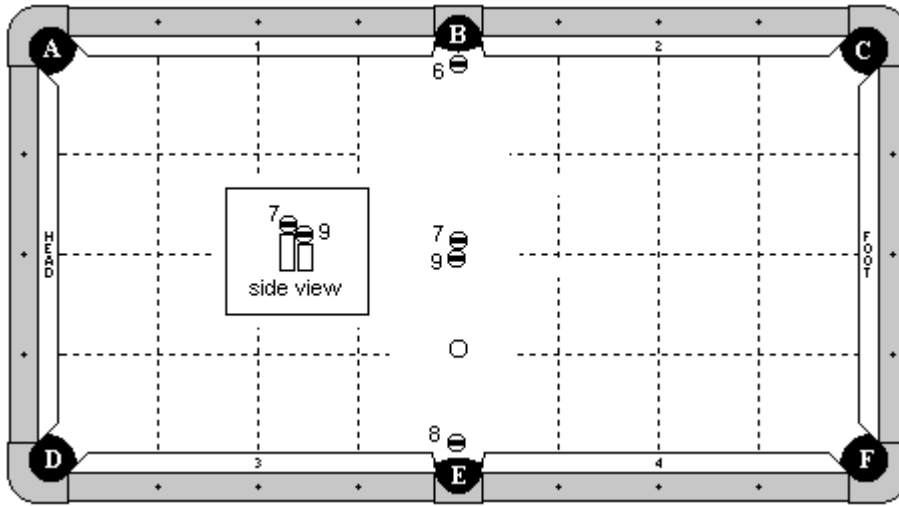

Category

Miscellaneous

Difficulty: 9

Cue Ball

In hand between the 8 and 9 balls.

Object Ball

6 ball hanging near pocket B. 7 ball on top of a long coin wrapper. 8 ball hanging near pocket E. 9 ball on top of a short coin wrapper. Both 7 and 9 balls are along the center (B-E) line.

Props

Coin wrappers as already described. Players may bring their own coin wrappers and cut them to length as needed.

Objective

Shoot the cue ball under the 7 & 9 balls, making the 6 ball in pocket B. The cue ball will get out of the way. The 7 and 9 balls will fall and split apart, with the 7 ball going into pocket B and the 9 ball to go into pocket E. As the 9 ball is rolling towards pocket E, jump the 8 ball over the rolling 9 ball, making the 8 ball in pocket B.

Special Notes

The 8 ball must be made in pocket B after the 7 ball is made. The 8 ball may not hit the 9 ball when jumping over it. The 8 ball must be made in pocket B before the 9 ball is made in pocket E. All balls must go in their pockets in numerical order. The decision by the referee is final. The cue ball may not scratch in pocket B. The 7,8,9 balls may not hit the cue ball by any means.

Shot 159

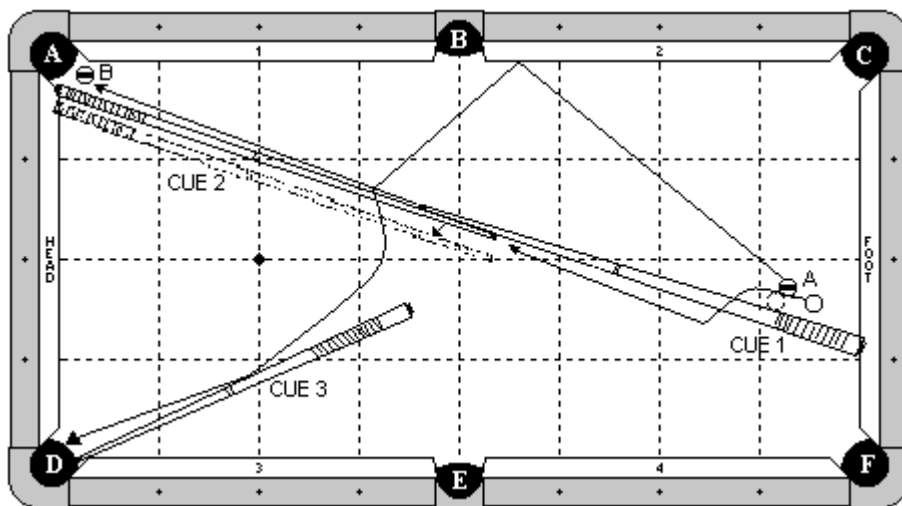

Category

Stroke

Difficulty: 10

Cue Ball

In hand, but no more than 2 ball's width from the foot cushion.

Object Ball

'A' ball is in hand, but no more than 1 chalk's width from the cue ball. 'B' ball is hanging near pocket 'A'. Three cue sticks are on the table. Cue stick # 1 has the butt end against the foot cushion at the 1st diamond. Cue stick # 2 has the butt end against the head cushion. Both cue stick # 1 and # 2 meet at the tip end and the sticks are both lined up so there is no gap between the sticks where they meet. Cue stick # 3 has the tip end wedged into pocket 'D' and it adjustable.

Props

Sticks, as diagrammed.

Objective

Shoot the cue ball into 'A' ball. 'A' ball will bank off cushion 2, hit and jump over the sticks (separating them), hit cue stick # 3 (optional), and go into pocket 'D'. The cue ball will jump over cue stick # 1, follow between the gap that now exists between the two cue sticks, and make 'B' ball in pocket 'A'.

Special Notes

The cue ball may hit cue stick # 1 when jumping over it. The cue ball must make 'B' ball. It may not be hit in by the cue stick.

Shot 160

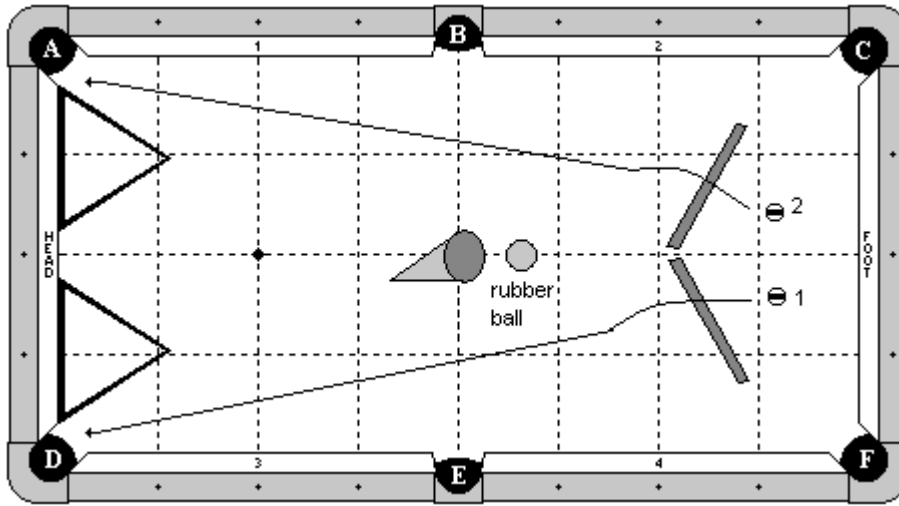

Category

Miscellaneous

Difficulty: 10

Cue Ball

None

Object Ball

Balls 1 and 2 are in hand, behind the wooden sticks. The path from the balls to their respective pockets must be towards the center of the wooden sticks and be completely blocked.

Props

Two wooden sticks, each $\frac{3}{4}$ inch tall, are in hand behind the foot string. Two racks are in hand, frozen to the head cushion. A plastic cone is held by the player in one hand. Inside the cone is a rubber ball. Players are free to use their own cone and ball.

Objective

Squeeze the cone and turn it upside down. Loosen your grip and let the rubber ball fall and bounce. After it bounces, the player must hit the 1 ball 1-handed, jump over the wooden stick, and go into pocket D. Then the player must catch the ball in the cone. Repeat the same process and jump the 2 ball into pocket A, except this time the rubber ball must bounce twice before the player hits the 2 ball and catches the rubber ball.

Special Notes

All hits on the 1 and 2 balls must be 1-handed and jacked up. In all cases, the rubber ball must finish all of its required bounces BEFORE the 1 and 2 are hit. For example, on the 2 ball, the rubber ball must bounce twice, and then the player hits the 2 ball, and then the player catches the rubber ball in the cone. The player may not hit the 2 ball before the rubber ball has bounced twice, nor may the player hit the 2 ball after catching the rubber ball in the cone. The player may tap the cone with the cue stick in order to avoid the rubber ball getting stuck. The hand holding the cone must stay approximately level with their shoulder, but in no case may the hand go above the top of the player's head. The referee will be the final judge. Fouls will only be called if the player is obviously raising his hand too high. The wooden sticks may not be touched by any means. The shot will be considered started once the rubber ball falls from the cone.

Shot 161

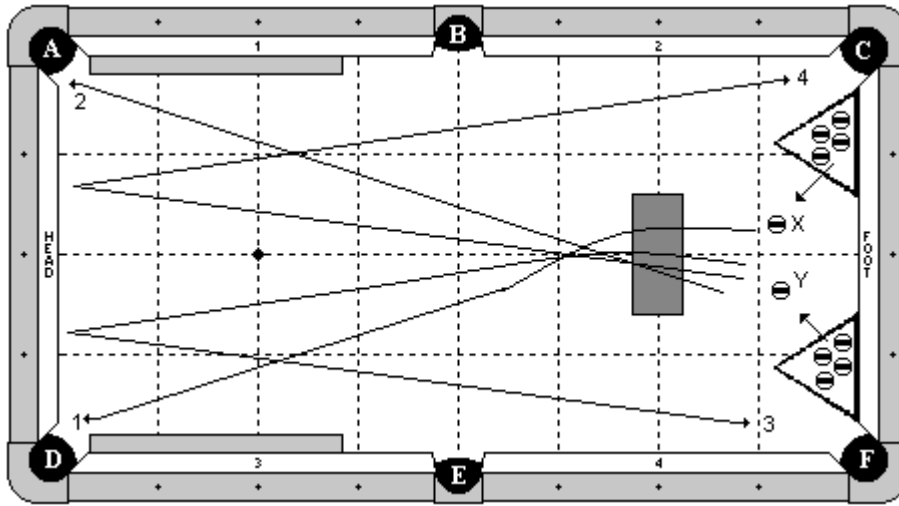

Category

Jump / Speed

Difficulty: 10

Cue Ball

None

Object Ball

4 object balls are in hand inside each rack. Balls in position X and Y are not on the table when the shot starts. Balls from inside the racks are moved into these two positions during the shot.

Props

Two racks are frozen to the foot cushion. Two cue stick butts are frozen to the long rails as diagrammed. A spinning rack is along the second diamond, centered on the foot spot. The rack is attached to the base with a magnet. The height of the rack that must be jumped over is approximately $2\frac{3}{4}$ inches. The rack spins at a rate between 10 and 25 RPMs. Players are free to use their own prop, provided it does not spin slower than 10 RPMs.

Objective

Take a ball out of one of the racks and place it anywhere behind the spinning rack (indicated by approximate positions X or Y). Jump that ball through the rack and into pocket D. Repeat and jump into pocket A. Repeat and jump / bank into pocket F. Repeat and jump / bank into pocket C. Repeat the entire process with the next 4 balls. The balls must go into the pockets in the following order: D, A, F, C, D, A, F, C. Because the rack spins in only one direction, there is no mirror image available to the players.

Special Notes

It is okay to disturb the balls / racks while removing the balls with your hand. The spinning rack or base may not be hit by any means. It is okay for any ball to hit the sticks positioned against the rails or the racks. The first jump can be done at any time. After the first jump, each $\frac{1}{2}$ revolution another ball must be jumped. In other words, if the opening of the rack on either side goes by without a ball being jumped through, the shot is no good. The balls from the left rack (near pocket F) must all be taken and jumped first, then the balls from the right rack (near pocket C).

Shot 162

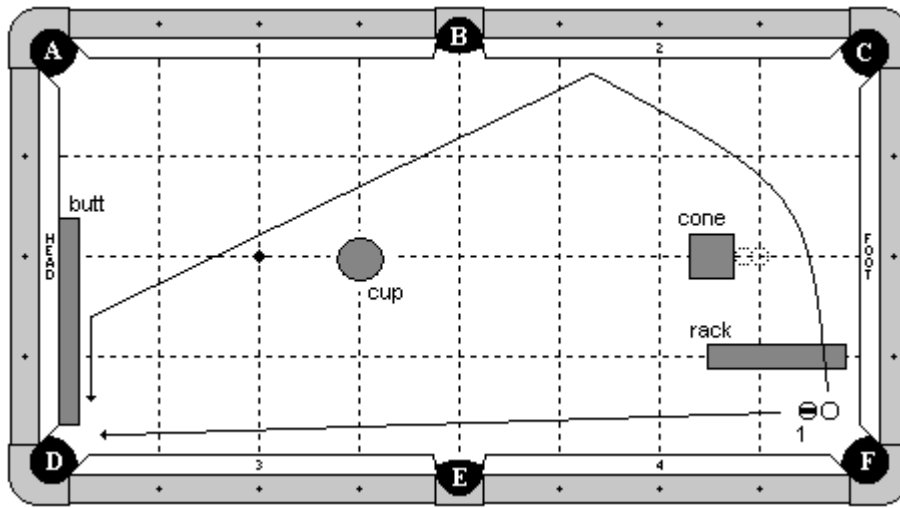

Category

Stroke

Difficulty: 10

Cue Ball

In hand within the 1x1 box zone, but must be a minimum of 2 balls width off the short rail.

Object Ball

In hand within the 1x1 box zone. The gap between the cue ball and object ball may be no more than the thickness of 1 domino (about 3/8 inch).

Props

The rack is standing upright, balancing on top of 4 dominos under each edge. Each domino has a thickness of about 3/8 inch. The rack is along the 1st diamond line and may be no more than 1 chalk's width off the cushion. A cue stick butt is frozen to the head cushion as diagrammed, but may be adjusted along the cushion. A plastic cone is standing on the long center line of the table, with its edge exactly 2 ball's width from the 1st diamond (the first spacer ball is centered on the 1st diamond).

Objective

Shoot the cue ball, causing the 1 ball to go into pocket D. The cue ball will jump through the rack, spin forward along the indicated line, going around the cones/cups as diagrammed, and go into pocket D, possibly with the help of the cue stick.

Special Notes

The cones/cups may not be touched by any means. It is okay to contact the rack, but it may not fall over. The 1 ball may not contact the stick. Players must shoot this shot with a full length cue. Players are free to use any plastic cone, cup, bottle, or any other objects they wish in place of the cone & cup diagrammed, provided that they are at least as wide as a standard 12 ounce cup or bottle.

Shot 163

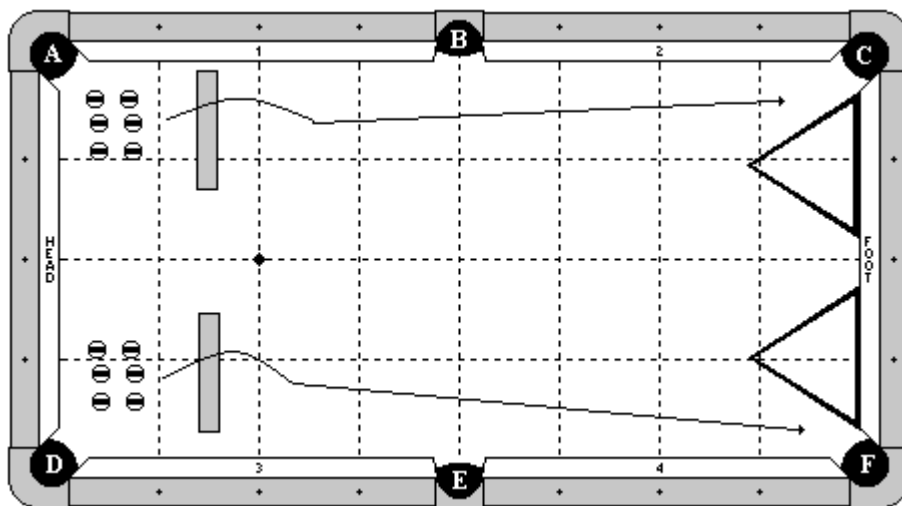

Category

Jump / Speed

Difficulty: 10

Cue Ball

None

Object Ball

2 rows of 3 object balls are placed behind each barrier as diagrammed. The object balls are in hand behind the 1st diamond line, but they must be positioned in such a way that they are totally behind the barrier. They must be configured approximately as shown.

Props

Two barriers are placed on the table at the 1 1/2 diamond line. They are 1/2 inch tall. Two racks are placed against the foot rail as shown, and may be braced with any object to keep them in place, provided that object doesn't interfere with the shot.

Objective

Holding 3 cue sticks at the same time, jump the first row of 3 object balls into pocket C. Then jump the second row into pocket C. Repeat with the other 6 balls into pocket F.

Special Notes

Three jump cues are used and they may not be held together by anything other than the player's hand. Each time the player jumps 3 object balls, all three hits must be approximately at the same time and in 1 forward motion stroke with all three jump cues. After jumping one set of 3 balls, if the player accidentally moves one or more of the other three balls, they may readjust them. The barriers may not be hit by any means. Once the shot starts, the player may not manually readjust the racks. There is a 20 second timer on this shot, which will start when the player jumps the first set of 3 balls, and ends when the player jumps (hits) the last set of 3 balls. CHANGED BY BILLIARDS INTERNATIONAL: 24 SECONDS WILL BE ALLOTTED FOR THIS SHOT.

Shot 164

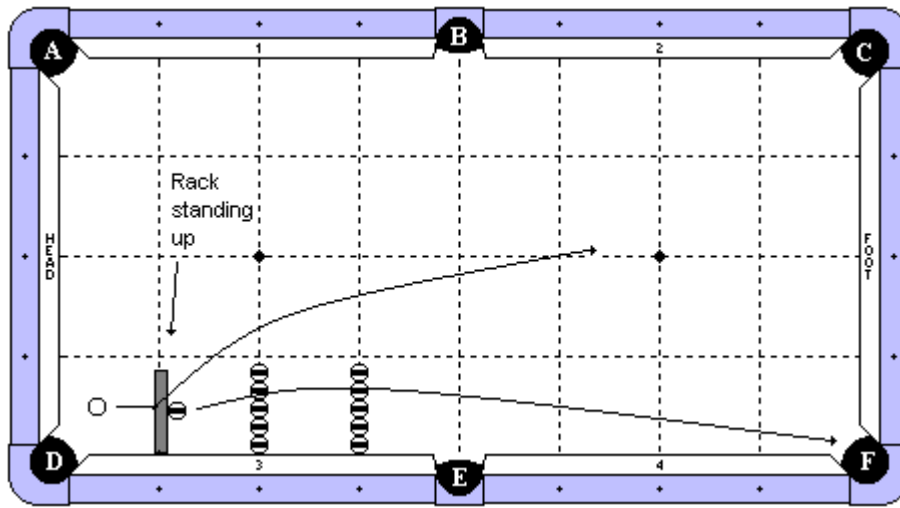

Category

Jump

Difficulty: 10

Cue Ball

In hand behind the rack.

Object Ball

An object ball is placed frozen to the rack and approximately centered as diagrammed. Two rows of 5 object balls are placed on the 2nd and 3rd diamond. They are frozen and straight in line, with the first ball frozen to the cushion..

Props

A rack is standing upright at the 1st diamond, frozen to the cushion.

Objective

Jump the cue ball through the rack and into the object ball, causing the object ball to fly over the two rows of barrier balls and into pocket F.

Special Notes

The barrier balls and the rack may not be contacted by any means until after the object ball goes into pocket F. The cue ball cannot fly off the table.

Shot 165

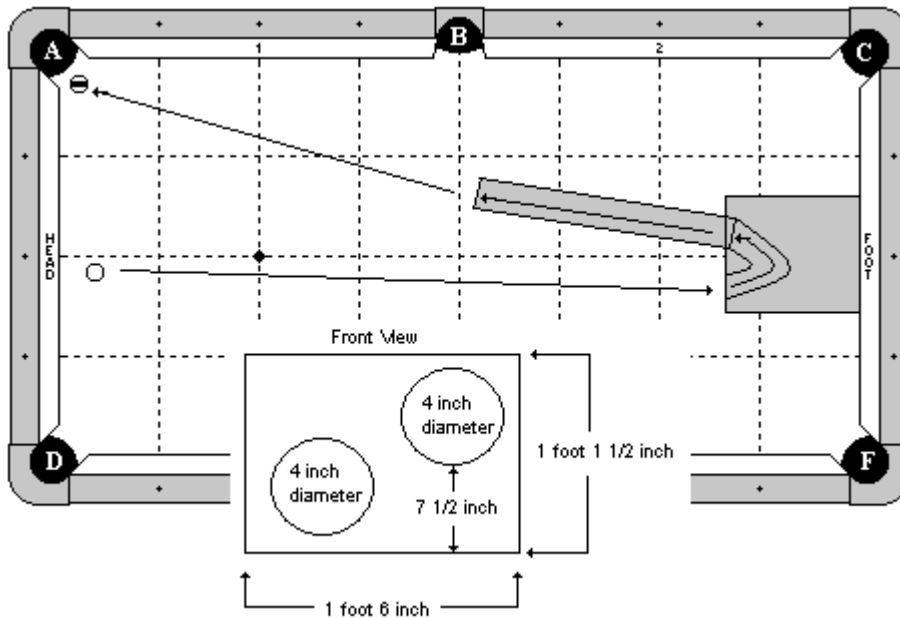

Category

Jump

Difficulty: 10

Cue Ball

In hand.

Object Ball

Hanging near pocket A.

Props

A box whose dimensions are provided is in hand against the foot cushion. The box is about 8 inches deep. The front of the box has two holes cut out, and there is a flexible tube connecting the two holes. A tube approximately 33 inches long (standard shipping tube) is placed inside the lower hole and pointed towards pocket A.

Objective

Jump the cue ball into the top hole. The cue ball will then come out of the lower hole, go through the long tube, and make the object ball in pocket A.

Special Notes

The player's bridge hand must be touching the head rail, and no part of the body (except the bridge hand) can touch the table. **CHANGED BY BILLIARDS INTERNATIONAL: PLAYER MAY JUMP HOWEVER THEY WANT, PROVIDED THAT THEIR BRIDGE HAND IS TOUCHING THE TABLE.**

Shot 166

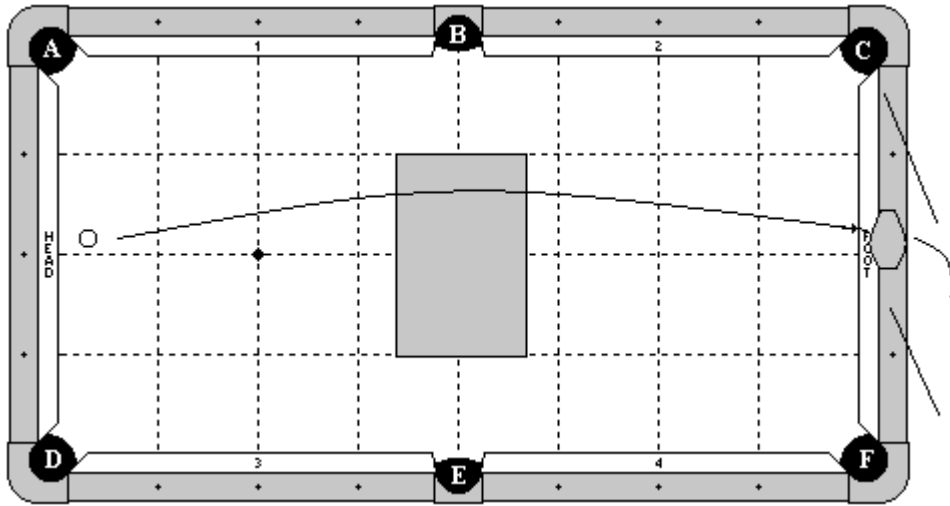

Category

Jump

Difficulty: 10

Cue Ball

In hand

Object Ball

None

Props

A 6 ½ inch x 3 ½ inch (approx) football is on a 1 ½ inch (approx) high tee. The tee is on the rail top. Two sticks are leaning against the table at each 1st diamond as diagrammed. The sticks may be braced with anything to keep them upright. The player is free to use anything as uprights, or not use the uprights at all. They are simply for show. A barrier 9 ½ inches high is placed in the center of the table and is in hand between the 3rd diamonds. Players are free to use anything as a barrier, provided it is 9 ½ inches tall.

Objective

Jump the cue ball over the barrier, into the football on the fly, and knock the football off the table.

Special Notes

The player's bridge hand must be touching the head rail, and no part of the body (except the bridge hand) can touch the table. CHANGED BY BILLIARDS INTERNATIONAL: PLAYER MAY JUMP HOWEVER THEY WANT, PROVIDED THAT THEIR BRIDGE HAND IS TOUCHING THE TABLE.

Shot 167

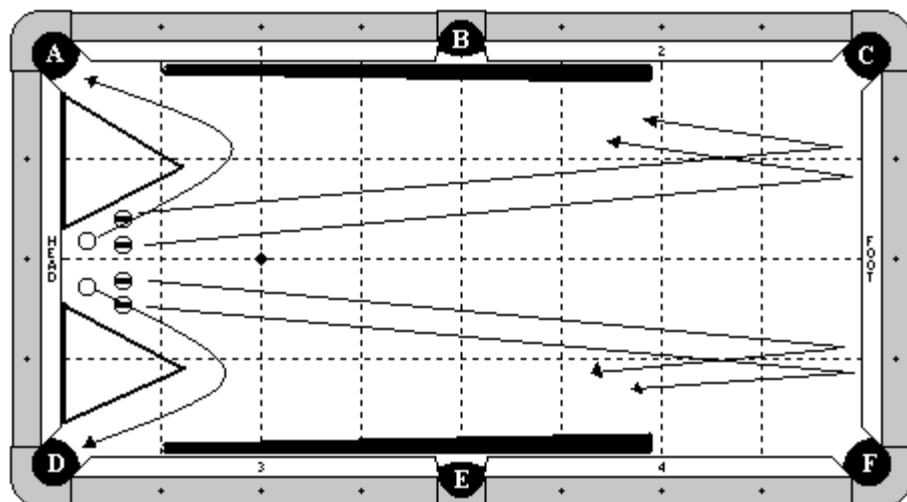

Category

Masse / Speed

Difficulty: 10

Cue Ball

Two cue balls are in hand between the racks but must be no more than one ball's width away from the head rail.

Object Ball

Two object balls are in front of each cue ball and no more than two balls' width away from each respective cue ball.

Props

Two racks placed as diagrammed. Two cues are placed along or near each long rail and are freely adjustable.

Objective

Shoot two numbered balls one after the other intending them to kick the foot rail and rebound to be pocketed in D with or without the help of the cue stick and/or rack. Before either numbered ball is pocketed, masse the first cue ball around the rack and into D. Quickly move to shoot the third and fourth numbered balls in the same manner to kick off of the foot rail and into pocket A. The third numbered ball must be struck before the second pocketed numbered ball falls in pocket D. Masse the second cue ball into pocket A before the third and fourth numbered balls fall in pocket A.

Special Notes

The numbered balls and the respective cue balls may contact one another but must go in the designated pocket in the specified order. The cue ball may not hit a rail other than the long rail near its pocket. The numbered balls may not hit a rail other than the foot rail and their respective long rail. The cue sticks, long rails, and racks need not be touched.

Shot 168

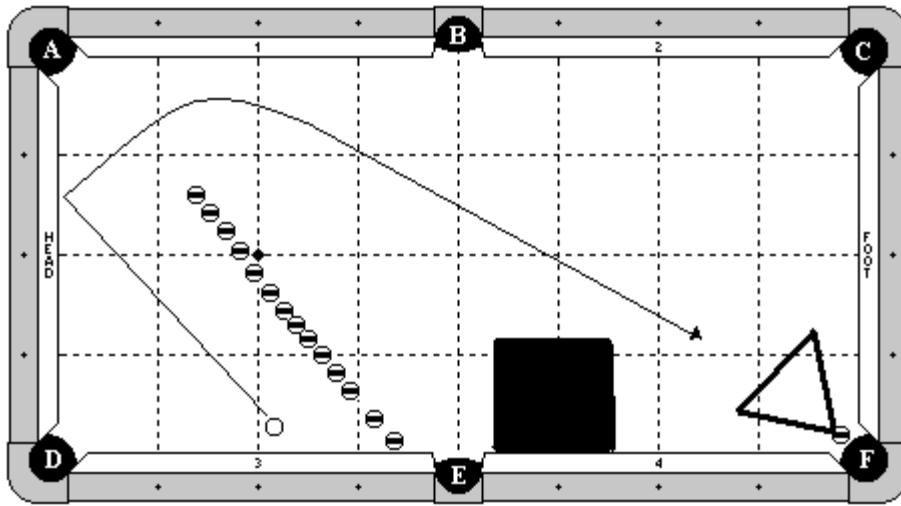

Category

Masse

Difficulty: 10

Cue Ball

In hand, beyond the head string but behind the wall of balls and no more than three balls' width away from the rail.

Object Ball

Fourteen object balls are placed in line starting at the half-diamond mark short of the side pocket and aimed at pocket A. They are frozen in line. Another object ball, to be pocketed is placed near pocket F.

Props

A rack is in hand and frozen to the object ball to be pocketed near F. An object is placed as diagrammed obstructing the cue ball's ability to come in short and hit the long rail near the side pocket. The obstruction can be anything that measures about 16 inches wide and sticks out from the long rail about 16 inches. This measurement may vary by 4 inches either way. Players may use their own prop and there is no other limitation as to what it may be.

Objective

Masse the cue ball off of the head rail and around the wall of balls and obstruction. The cue ball will then bend its path to strike the rack and pocket the object ball. The rack must pocket the object ball. The obstruction and wall of balls may not be contacted until the object ball is made.

Special Notes

The long rail on the top of the diagrammed table may not be touched by any means. The lower long rail may be touched so long as the rack is struck which pockets the object ball.

Shot 169

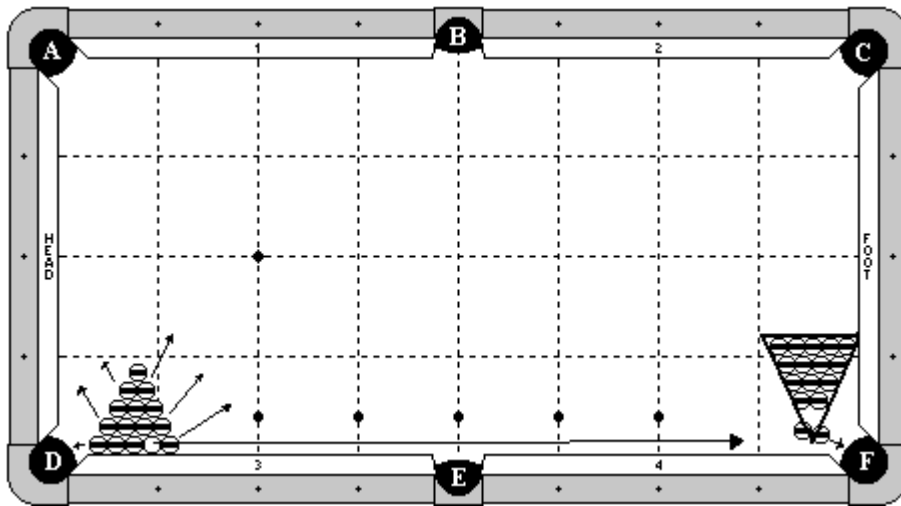

Category

Masse

Difficulty: 10

Cue Ball

As diagrammed, the fourth ball from the pocket point of D.

Object Ball

Fourteen object balls are frozen in a racked position along with the cue ball. Fourteen more are within a rack near pocket F as diagrammed. Two object balls are frozen to one another under the propped up rack, near pocket F

Props

Five pins or empty bottles are as diagrammed at each diamond interval starting on the headstring, exactly two balls' width from the long rail. A rack is placed around the fourteen balls near pocket F with the corner of the rack frozen to the foot rail. The rack is propped up on top of the two frozen balls nearest pocket F.

Objective

Masse the cue ball, making at least one ball in pocket D. The ball to the right of the cue ball will get out of the way and the cue ball will spin down the long rail to make a combination and pocket the ball nearest F. The object ball frozen to the ball nearest F, upon which the rack is propped, will fall into the empty head ball spot and the rack will fall into place, around the now full rack of 15 balls.

Special Notes

The cue ball may hit the pins but it may not cause them to fall. The object balls from the full rack near D may strike and knock over pins.

Shot 170

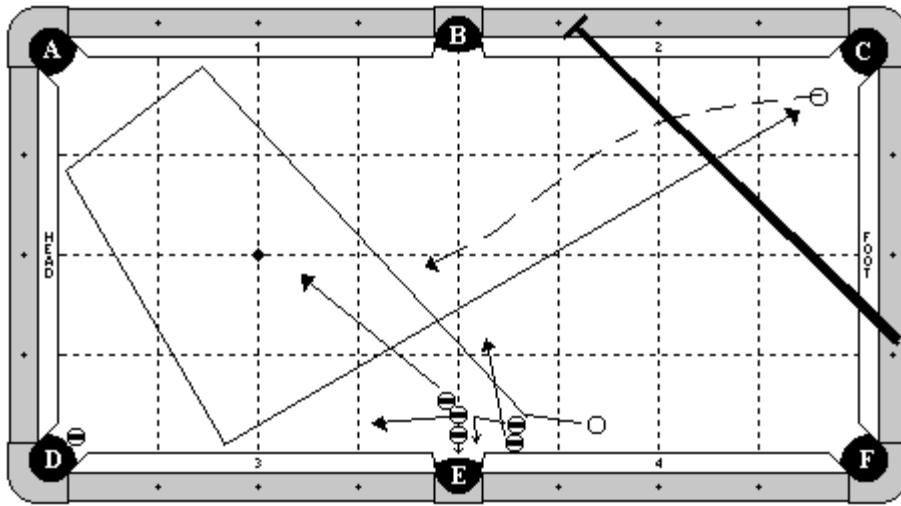

Category

Jump

Difficulty: 10

Cue Ball

As diagrammed, adjustable.

Object Ball

An object ball is in hand near pocket D. Five object balls are positioned near pocket E in the traditional “Just Showin’ Off” fashion and adjustable.

Props

A bridge is laid across the table resting on the foot and long rails as diagrammed and adjustable.

Objective

Shoot the cue ball into the first ball of the cluster. That ball will bank the second ball to B then drive into the cluster of three and ultimately be pocketed in E. The ball nearest E will be pocketed in E. The far ball will be pocketed in A. The middle ball of the pack, typically pocketed in D, will travel to pocket the ball sitting in front of D, then remain there momentarily. The cue ball will travel three rails without colliding with any other balls and pass under the bridge. Once it passes under the bridge, the cue ball must be jumped over the bridge to pocket the ball now at rest in front of pocket D.

Special Notes

The cue ball may contact the long rail or short rail near pocket C so long as it is still in motion when it is struck and jumped over the bridge. The bridge may be contacted by the jumped cue ball. In the event that the middle object ball pockets the ball near D then follows it in, the cue ball may be jumped over the bridge and scratch in pocket D. This will be deemed a successfully completed shot. Players must use two cues for this shot, one for each stroke, holding one at a time.

Shot 171

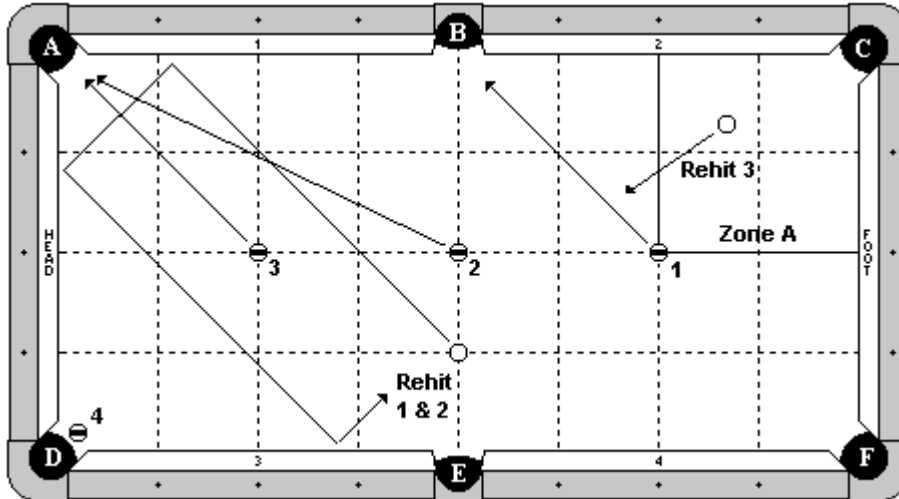

Category

Juggling / Speed

Difficulty: 10

Cue Ball

Intersection of center and first diamond line

Object Ball

Object ball 1 on foot spot. Object ball 2 center table. Object ball 3 on head spot. Object ball 4 hanging near pocket D

Props

None

Objective

Shoot cue ball three rails around ball 3 using cushions 1, head and 3. Shoot 1 into pocket B. Re-hit cue three rails around ball 3 using cushions 1, head and 3. Shoot 2 into pocket A. Re-hit cue three rails around ball 3 using cushions 1, head and 3. Shoot 3 into pocket A. Shoot cue into 4 ball pocketing 4 in D.

Special Notes

The 3rd re-hit must be shot from 2x2 Zone A. Cue must not stop until after 4 ball is pocketed. All shots must be shot one handed jacked.

Shot 172

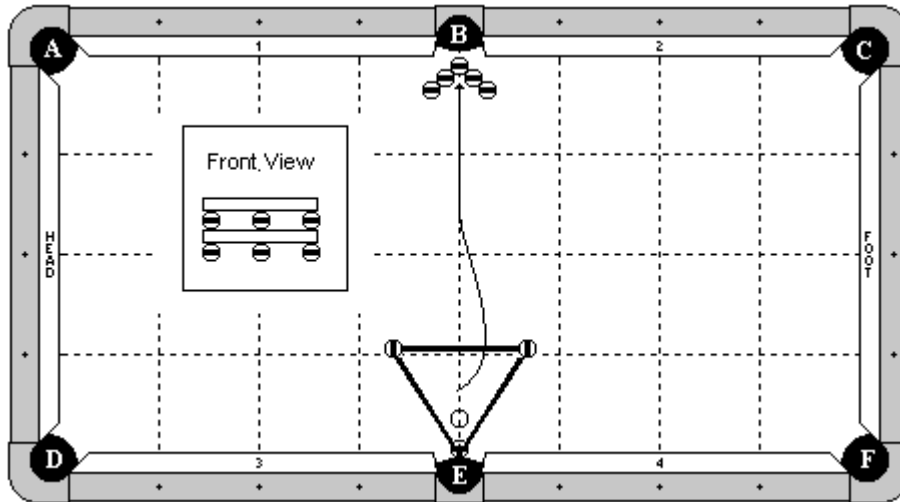

Category

Jump

Difficulty: 10

Cue Ball

Inside rack

Object Ball

Hanging near pocket B in the apex position of a “V” formation involving 4 “helper” balls.

Props

Three balls are placed in a triangle with a rack propped on top of them supported at the corners. Three more balls are placed on each corner of the rack. Another rack is placed on top. The tower of balls and racks are position with one corner near pocket E and centered along BE line.

Objective

Jump cue over the top of the racks and pocket object ball in pocket B.

Special Notes

The cue ball may not touch the racks or object balls used to stack the racks. Must be shot free-handed with both feet touching floor.

Shot 173

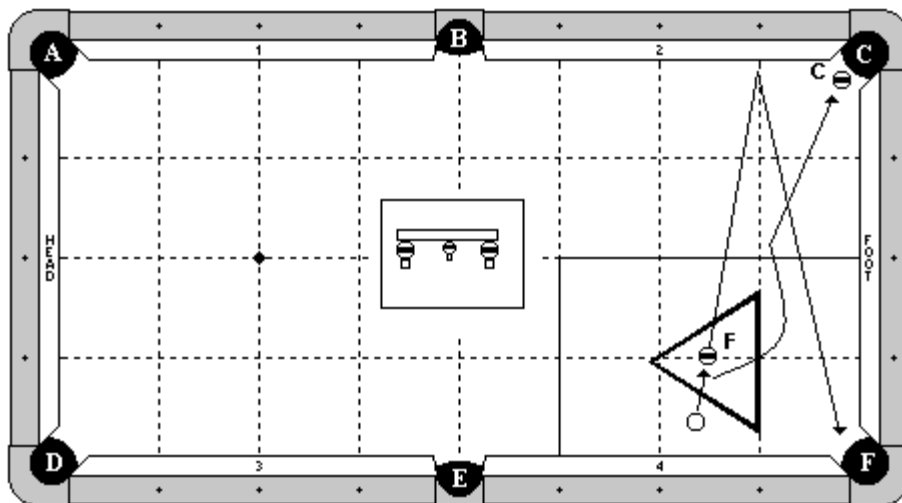

Category

Jump

Difficulty: 10

Cue Ball

In hand

Object Ball

F ball is inside rack. C is hanging near pocket C.

Props

3 chalk cubes are placed in a triangle. 3 balls are placed on the chalk cubes. A rack is propped on top of the balls supported at the corners. The assembly must stay within indicated zone.

Objective

Bank F ball off cushion 2 into pocket F. Before F is pocketed, re-hit cue ball, jumping over the top of the rack pocketing C.

Special Notes

Cue must be re-hit from inside the rack. The cue ball must be jumped before 'F' ball is made. It is okay for the cue ball to pocket 'C' ball after 'F' ball is made, provided that the second hit on the cue ball (the jump) is hit before 'F' ball is made.

Shot 174

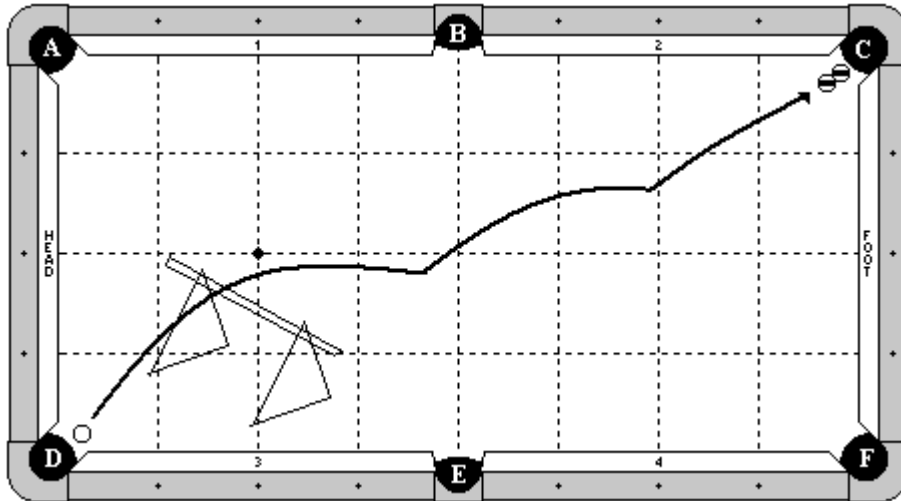

Category

Jump

Difficulty: 10

Cue Ball

In hand within 2 ball space of slate cut of pocket "D"

Object Ball

Two object balls are hanging near pocket "C"

Props

Two Delta-13 racks are standing upright. A shaft is inserted between the top holes approximately 12 inches above the slate. The center of the shaft intersects the head string.

Objective

Jump cue ball over shaft and make 2 ball combination.

Special Notes

Shaft and racks cannot be contacted by any means until after object ball is pocketed. It is ok for the cue ball to leave the table as long as object ball is pocketed. Must be shot free-handed with both feet touching floor. CHANGED BY BILLIARDS INTERNATIONAL: THE REQUIREMENT THAT BOTH FEET NEED TO BE TOUCHING THE FLOOR HAS BEEN REMOVED.

Shot 175

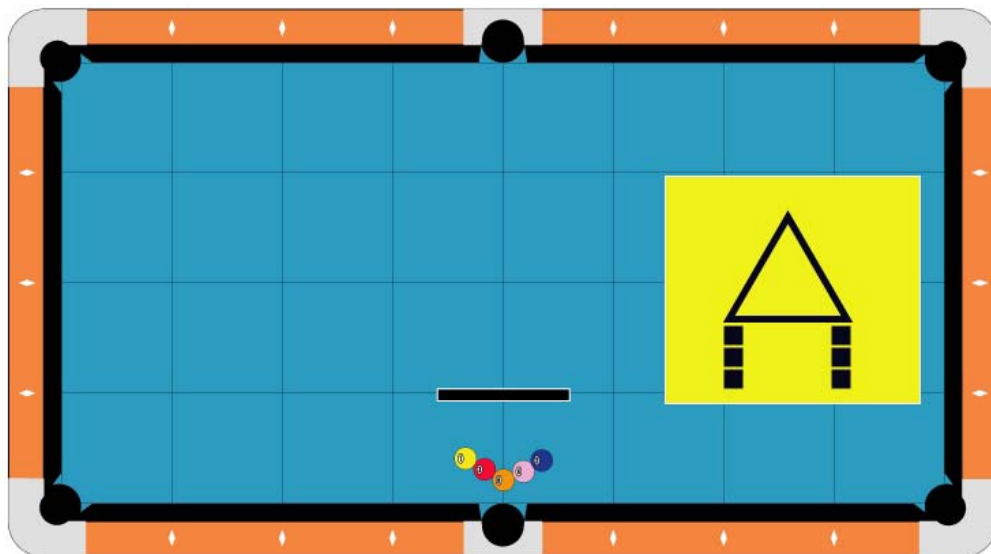

Category

One-handed jump / speed

Difficulty: 9

Cue Ball

N/A

Object Ball

5 balls are placed in-hand but must respect the chevron shape. (Order is 1, 3, 5, 4 & 2) reverse order if player is left-handed

Props

A rack (Delta-13) is sitting upright on 3 chocks inside the cavity of rack centered at the middle of the table and on the 1st diamond.

Objective

Jump all 5 balls in numerical order

1 – 3 – 5 (left-handed)

2 – 4 (right-handed)

Special Notes

This shot must be performed within 10 seconds from 1st strike to last

Player feet must remain in place. If they move from their planted spot, the shot is no good. The rack may not be contacted by any means.

Shot 176

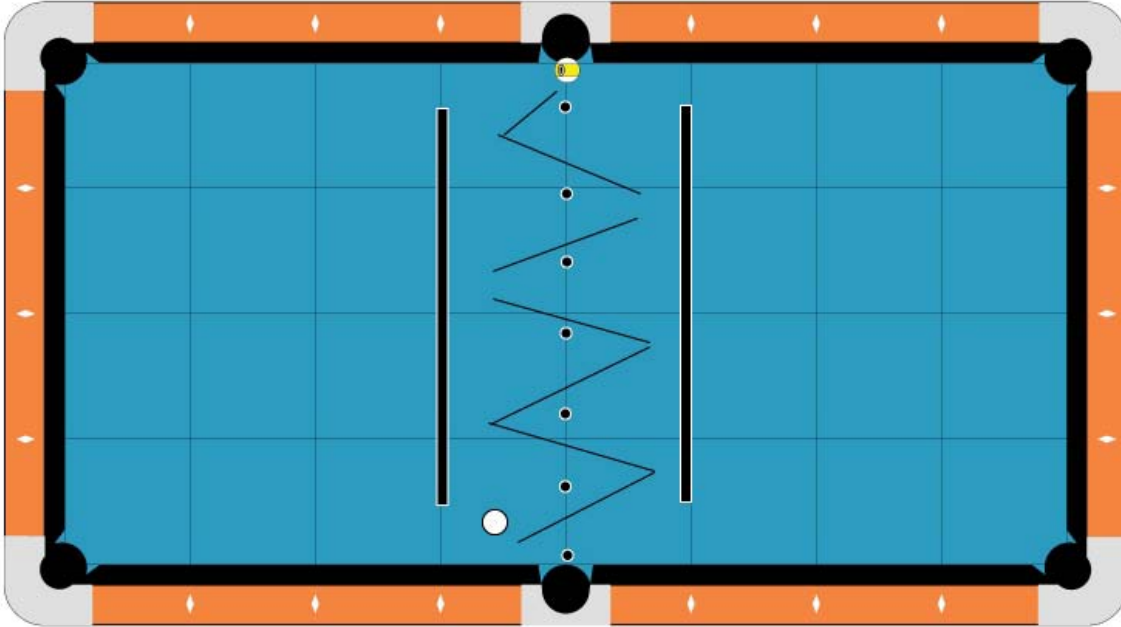

Category

Juggling

Difficulty: 9

Cue Ball

In hand, between the first 2 sets of chalks.

Object Ball

In-hand in front of the opposite side pocket

Props

2 jump cues are used. They are placed on the first diamond on each side of the center of the table.

7 sets of chalks (3 high) are placed with a gap of 3 balls between them.

The 1st set starts at the beginning of the slalom course at the cut of the pocket.

Objective

Volley in and out of each opening without touching any of the chalk towers and pocket the object ball in front of pocket B. If the cue ball should touch any of the 2 barrier cues, the shot is no good.

Special Notes

The cue ball may never come to a stop. This shot must be performed with one cue and with all one-handed hits. Players will switch hands between hits, shooting as follows (left, right, left, right, left, right, left)
(Reverse order if player is left-handed)

Shot 177

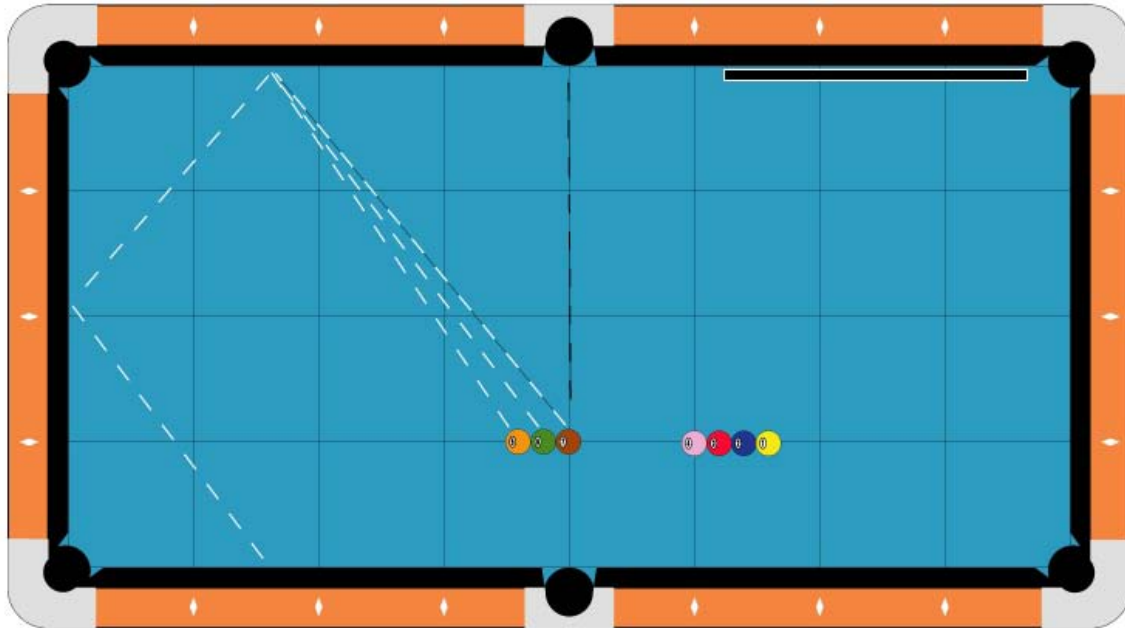

Category

Juggling / Speed

Difficulty: 9

Cue Ball

N/A

Object Ball

2 groups of balls are used.

5, 6 & 7 are frozen as diagramed and placed on the first diamond with the 7 on the center of the table to the left of the side pocket.

4, 3, 2 & 1 are frozen as diagramed and placed on the first diamond with the 4 ball on the first diamond to the right of the side pocket.

Props

A butt of a cue is used and is placed along the rail as diagramed.

Objective

Strike the 5, 6 & 7 3 rails then make the 1 in the top right corner.

Re-hit the 5, 6 & 7 3 rails then make the 2 in the top right corner.

Re-hit the 5, 6 & 7 3 rails then make the 3 in the top right corner.

Re-hit the 5, 6 & 7 3 rails then make the 4 in the top right corner.

The 5, 6 & 7 will travel 3 rails off the butt in the same pocket as the 1, 2, 3 & 4.

Special Notes

All balls must be pocketed in numerical order.

5, 6 & 7 may never come to a stop and must always be struck in order. They may not go past the center of the table.

5, 6 & 7 must be struck right-handed

1, 2, 3 & 4 must be struck left-handed with the bridge hand on the playing surface. (it can not be placed up side down). CHANGED BY BILLIARDS INTERNATIONAL:

PLAYER'S BRIDGE HAND MAY BE HELD HOWEVER THEY WANT.

Shot 178

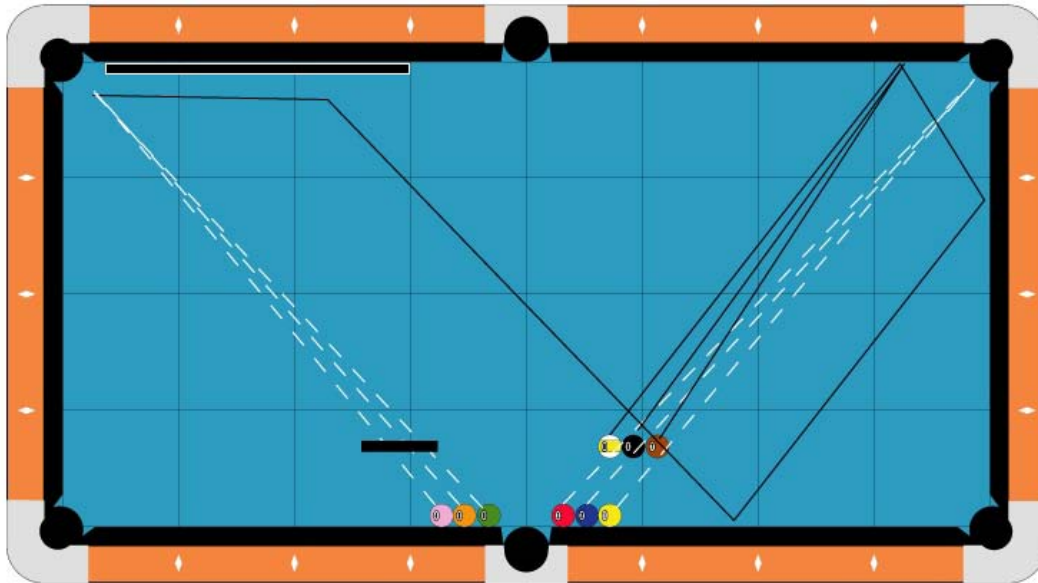

Category

Jump / speed

Difficulty: 9

Cue Ball

N/A

Object Ball

Place the 3, 2 & 1 frozen to the rail and each other with the edge of the 3 flush to the cut of the pocket.

Place the 6, 5 & 4 frozen to the rail and each other with the edge of the 6 flush to the cut of the pocket.

Place the 9, 8 & 7 frozen 3 balls out from the rail. (9 must be aligned with 1)

Props

A wall of chalks measuring 3 high is placed directly in front of the path of the 4, 5 & 6 (perpendicular at 2 balls out from the 4 ball)

A butt of a cue is in hand and positioned on the long rail.

Objective

Jump the 1, 2 & 3 over the 9, 8 & 7 into the corner pocket.

Then strike the 7, 8 & 9 3 rails into the opposite corner (with the help of cue butt)

Jump the 4, 5 & 6 into the same corner as the 7, 8 & 9. (butt may not be hit)

All balls must be made in numerical order.

Special Notes

This is a timed shot with a total of 18 seconds.

The wall of chalks may not be touched

7, 8 & 9 can not be touched when jumping 1, 2 & 3.

Shot 179

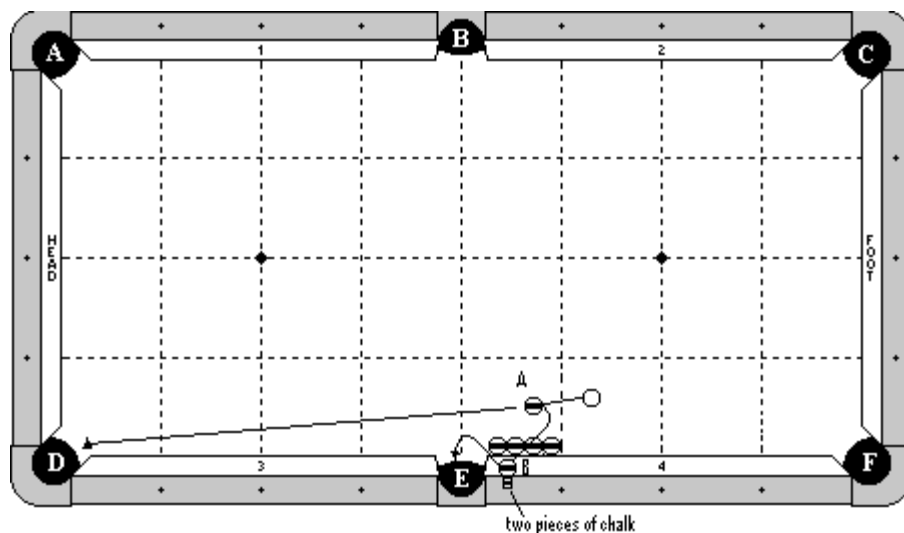

Category

Miscellaneous

Difficulty: 10

Cue Ball

In hand

Object Ball

'A' ball is in hand. 'B' ball is balanced on top of two chucks on the rail top. A row of 4 balls are frozen to the cushion, with the edge of the first ball aligned with the pocket point as diagrammed.

Props

A stack of two chucks (under 'B' ball) is on the rail top near pocket 'E' as indicated by diagram.

Objective

Shoot the cue ball to 'A' ball, making 'A' ball in pocket 'D'. The cue ball will jump and make 'B' ball in pocket 'E'.

Special Notes

The cue ball may not touch the row of blocking balls. It is okay for the cue ball to fly off the table.

Shot 180

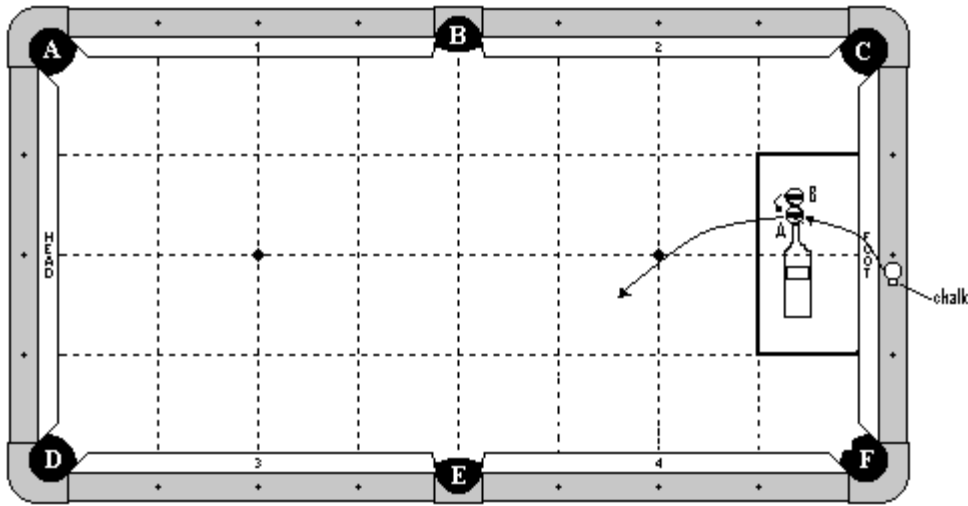

Category

Miscellaneous

Difficulty: 10

Cue Ball

On top of a piece of chalk, on the foot rail as diagrammed.

Object Ball

'B' ball is balanced on top of a special stacking ball ('A' ball).

Props

Chalk cube is in hand on the rail top. Bottle is in hand and is 22cm in height. Stacking ball is on top of the bottle ('A' ball).

Objective

Shoot the cue ball into 'A' ball. 'B' ball will fall and remain on top of the bottle.

Special Notes

Scratch is not allowed. Players can use their own bottle as long as it is between 21cm and 23cm tall. 'A' ball doesn't have to be made.

Shot 181

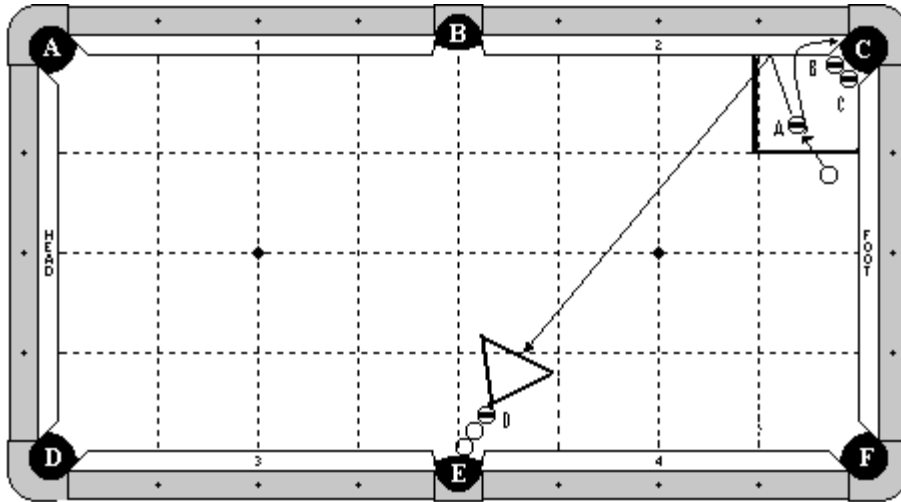

Category

Miscellaneous

Difficulty: 10

Cue Ball

In hand

Object Ball

'A' ball in box zone. 'B' and 'C' balls are hanging near pocket 'C' as diagrammed. 'D' ball is two ball's width from the pocket cut of pocket 'E' (ghost balls are diagrammed and are not on the table for the actual shot).

Props

A rack is frozen to 'D' ball as diagrammed.

Objective

Shoot the cue ball into 'A' ball, causing it to bank into the rack, making 'D' ball in pocket 'E'. The cue ball will jump over the two blocking balls, into pocket 'C'.

Special Notes

The cue ball may not contact either blocking ball.

Shot 182

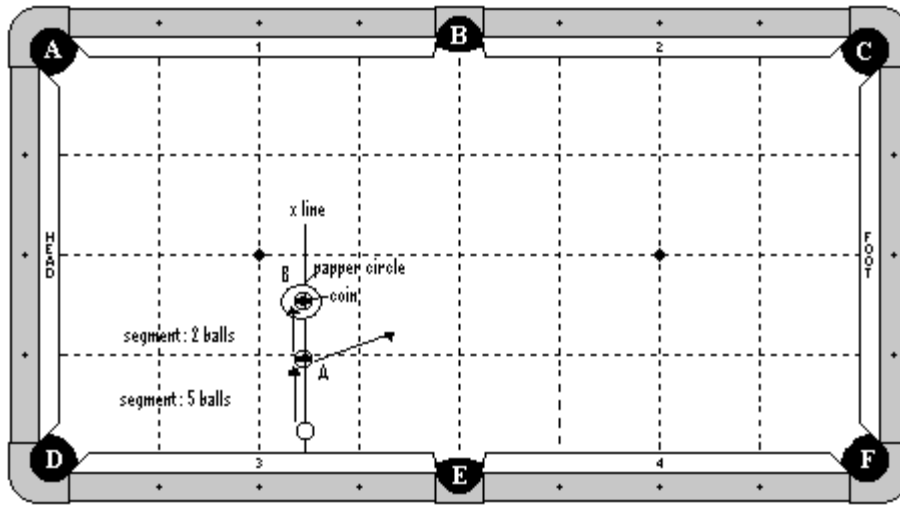

Category

Miscellaneous

Difficulty: 10

Cue Ball

In line with other balls along the 'X' line. It may be adjusted along this line, anywhere between 'A' ball and cushion 3. 'X' line is any line straight across the table between the 2nd and 3rd diamonds.

Object Ball

'A' ball and 'B' ball are both on the indicated 'X' line. 'A' ball is exactly 5 ball's width from cushion 3. 'B' ball is exactly 2 ball's width from 'A' ball.

Props

A paper circle is placed directly under 'B' ball. It is 7cm diameter. A quarter is balanced on top of 'B' ball. 'B' ball is centered on the circle.

Objective

Shoot the cue ball to 'A' ball. Immediately 'A' ball must be removed with one hand. Then the cue ball will hit 'B' ball, causing the coin to fall on the paper circle.

Special Notes

'A' ball cannot touch 'B' ball. Only the cue ball may touch 'B' ball. The shot must be a legal shot. The shot must be performed 2 handed, and the hand holding the shaft must stay on the rail when the cue stick hits the cue ball. The cue ball must contact 'A' ball before you remove it with your hand. 'A' ball must be moving when you remove it with your hand. The coin must fall on the paper circle. The edge of the coin may not overhang the edge of the paper. It must fall and stay completely within the paper circle.

Shot 183

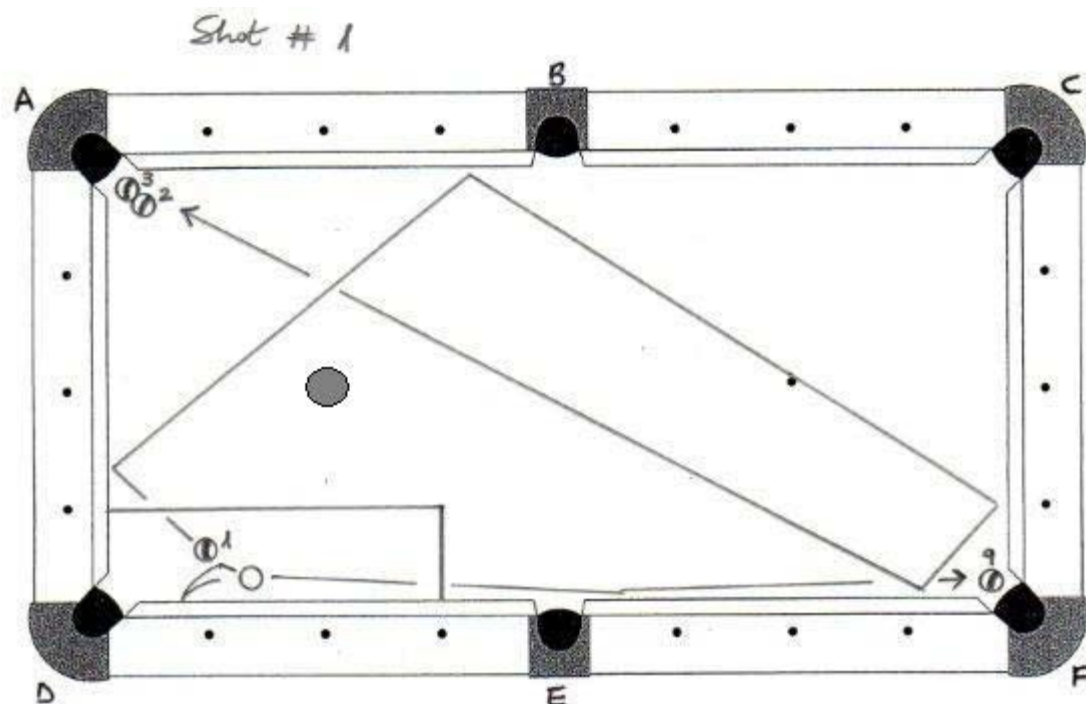

Category

Stroke

Difficulty: 10

Cue Ball

In hand anywhere within zone X.

Object Ball

OB 1 at 2-ball distance from CB, still within zone X. OB 2 and 3 by pocket A and OB 9 by pocket F.

Props

A standard sized bottle or can is placed on the head spot as diagrammed.

Objective

With the cue leveled (no masse), shoot into the OB 1 and make it travel 4 rails to pocket the 3-ball into pocket A (hitting one more rail by pocket A is allowed). As diagrammed, in the meantime the CB hit the long rail and draws back to make the 9-ball into F-pocket. Of course the long rail can be hit multiple times by the CB on its way to hit the 9-ball.

Special Notes

In case of a collision between the CB and the 1-ball the attempt is not good. The 1-ball may not contact the bottle until after the 3-ball is made. The player has the option of using silicone on the cue ball.

Shot 184

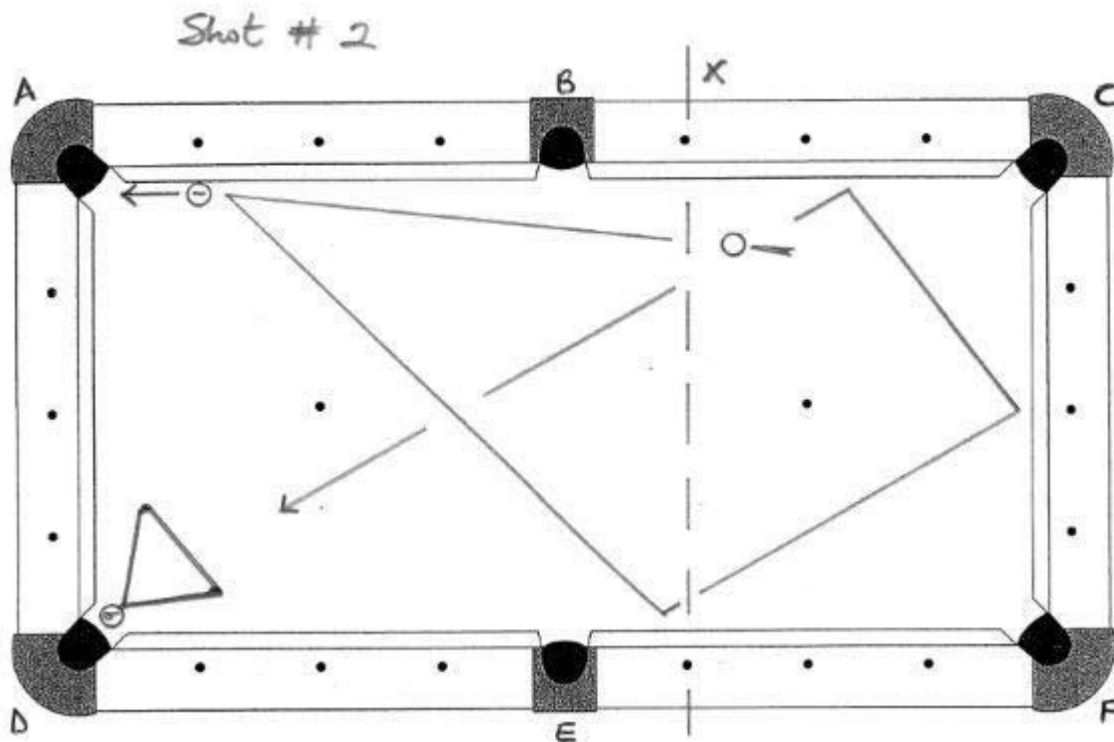

Category

Stroke

Difficulty: 10

Cue Ball

In hand anywhere behind line X.

Object Ball

OB 1 is frozen to the long rail at the first diamond from pocket A. The 9-ball is centered between the points of pocket D and a standard rack is frozen to it, as diagrammed.

Props

A standard rack is placed on the table, frozen to the 9-ball.

Objective

Pocket the 1-ball into A-pocket and draw back to hit 3-rails (long, short, long) and the rack to make the 9-ball into D-pocket.

Special Notes

No extra rails can be hit. The first rail that the cue ball hits may be on either side of pocket E.

Shot 185

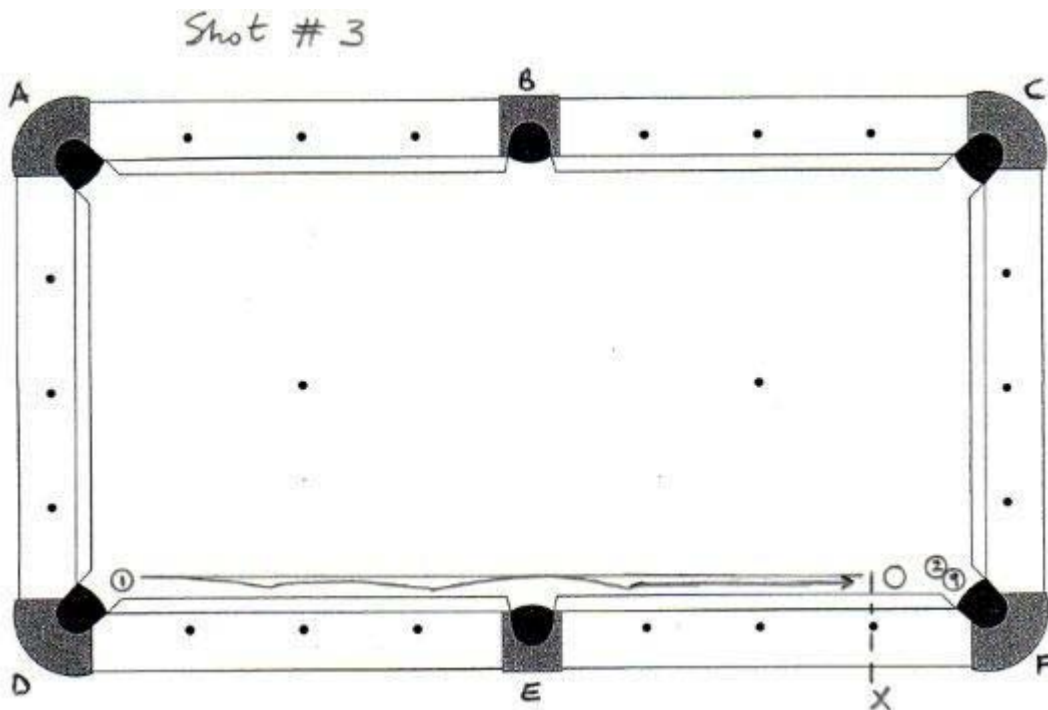

Category

Masse

Difficulty: 10

Cue Ball

In hand behind line X at no more than $\frac{1}{2}$ inch from the long rail.

Object Ball

OB 1 is placed by pocket D centered with the right pocket's point and at no more than $\frac{1}{2}$ inch from the long rail. The frozen combo 2-9 is placed as diagrammed, with the 9-ball centered between pocket F's points.

Props

The cue ball will be waxed for this shot.

Objective

Masse the CB along the long rail to pocket the 1-ball into D-pocket and draw back to hit the 2-ball and make the 9-ball into F-pocket.

Special Notes

The CB can only hit the long rail D-E-F on its way to and from the 1-ball. The masse must be executed 'free handed', which means that the forearm may be wedged up against the body, but the bridge hand may not. In addition, the player must have both feet flat on the floor, and may not sit or climb on the table in any way. Leaning on the table is okay.
CHANGED BY BILLIARDS INTERNATIONAL: PLAYER MAY MASSE HOWEVER THEY WANT. NO RESTRICTIONS ON HOW THEY ARE STANDING, SITTING OR LEANING, PROVIDING THAT THEY USE A FREE HAND BRIDGE AS EXPLAINED ABOVE.

Shot 186

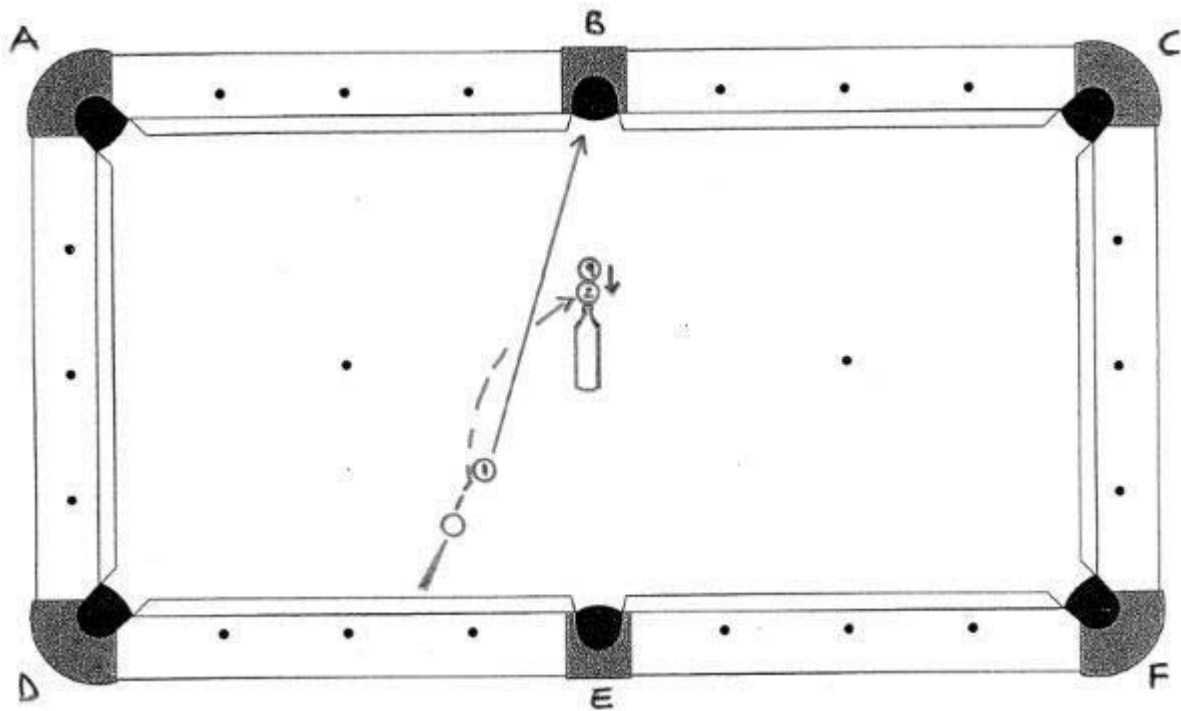

Category

Miscellaneous

Difficulty: 10

Cue Ball

In hand

Object Ball

OB1 in hand

Props

A metallic bottle 9.5 inches tall and with a 1 inch diameter cap is placed towards the center of the table. On top of the cap is placed a doctored ball and on top of it, the 9-ball.

Objective

Jump the CB off OB1 to pocket it into B. While airborne the CB hits the doctored ball and knocks it away, making the 9-ball drop and STAY on the bottle.

Special Notes

The CB cannot fly off the table.

Shot 187

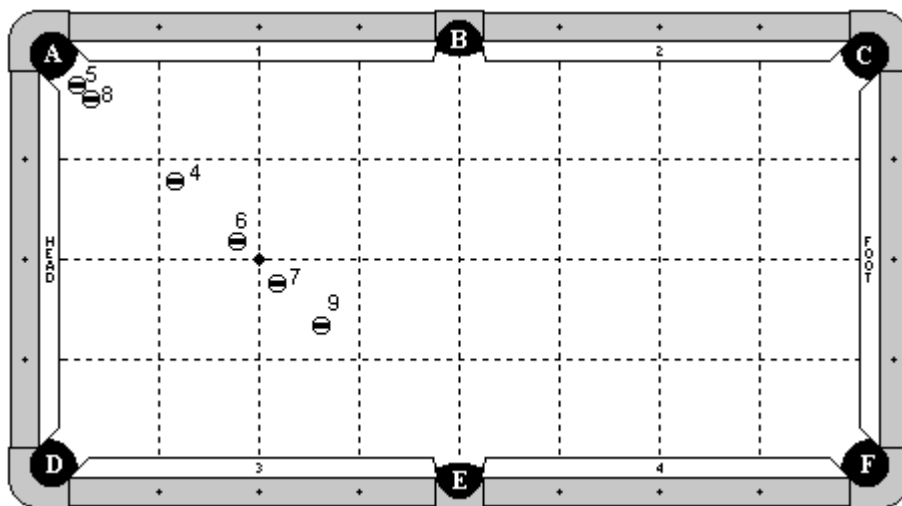

Category

Miscellaneous

Difficulty: 10

Cue Ball

None

Object Ball

4,5,6,7,8,9 balls are placed as diagrammed and are all in a straight line. The 5 and 8 are on coin wrappers, with the 5 on a taller coin wrapper (4 1/6 inch max) and the 8 on a smaller coin wrapper (2 9/16 max). The 5 ball must be a minimum of 2 ball's width from the pocket cut. The 4 ball is halfway between the 8 and 6 balls. The balls may be adjusted by the player provided that they meet the specifications already mentioned.

Props

Two coin wrappers as previously described.

Objective

Shoot the 4 ball under the 5 and 8, into pocket A. The 5 and 8 will fall, with the 5 also going into pocket A, and the 8 rolling towards the 6 ball. Jump the 6 ball over the 8 ball into pocket A. Then jump the 7 ball over the 8 ball into pocket A. Then shoot the 8 ball into pocket A. Then shoot the 9 ball into pocket A. All balls will go into pocket A in numerical order.

Special Notes

The 8 ball must be moving when hit. The 9 ball must be hit before the 8 ball goes in. Referee decision is final. Other than the 5 ball hitting the 8 ball when falling, no other balls may contact each other until all balls are made. The numerical order of placement is very important so the referee can judge the success of the shot. Players should place the balls in the correct numerical sequence as described above.

Shot 188

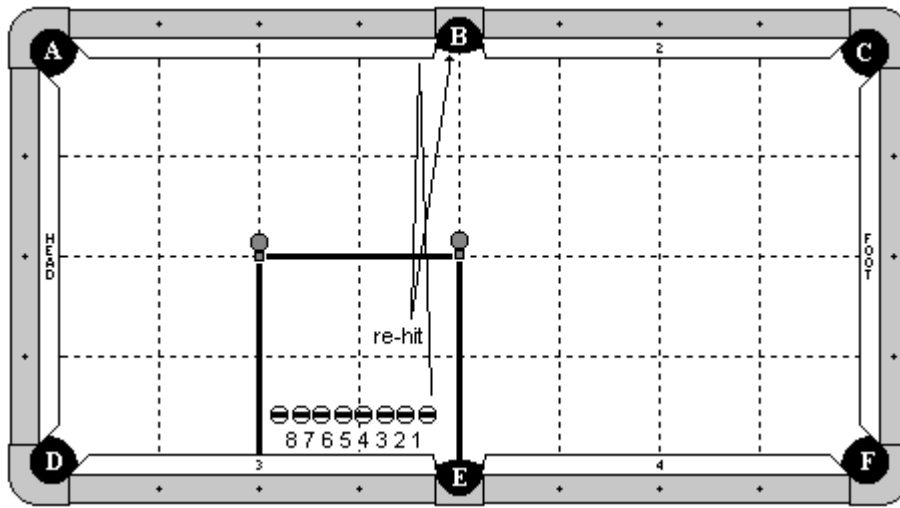

Category

Speed

Difficulty: 10

Cue Ball

None

Object Ball

1 through 8 balls are in hand within the indicated zone, but they must all be in a straight line and in the order as diagrammed.

Props

A piece of chalk is on the head spot and another is on the exact center of the table. An object ball is placed on top of each piece of chalk.

Objective

Shoot the 1 ball to cushion # 1 and back again. While the 1 ball is rolling, shoot the 2 ball to cushion # 1, jumping it back and catching it in your hand. Drop it in pocket E. Then re-hit the rolling 1 ball into pocket B. Repeat for the 3 & 4, 5 & 6, 7 & 8. The odd numbered balls will be banked and re-hit into pocket B. The even numbered balls will be jumped, caught, and placed in pocket E.

Special Notes

The balls on the chalk may not be hit by any means. The 1,3,5,7 must be rolling when re-hit and they may not hit any cushion except for cushion # 1. They must also be re-hit only when they have fully returned into, and from within the indicated zone. The balls may not contact each other during the shot. When catching the ball, it must be caught in the player's hand, and may not be trapped by the body. The shot must be completed in 24 seconds.

Shot 189

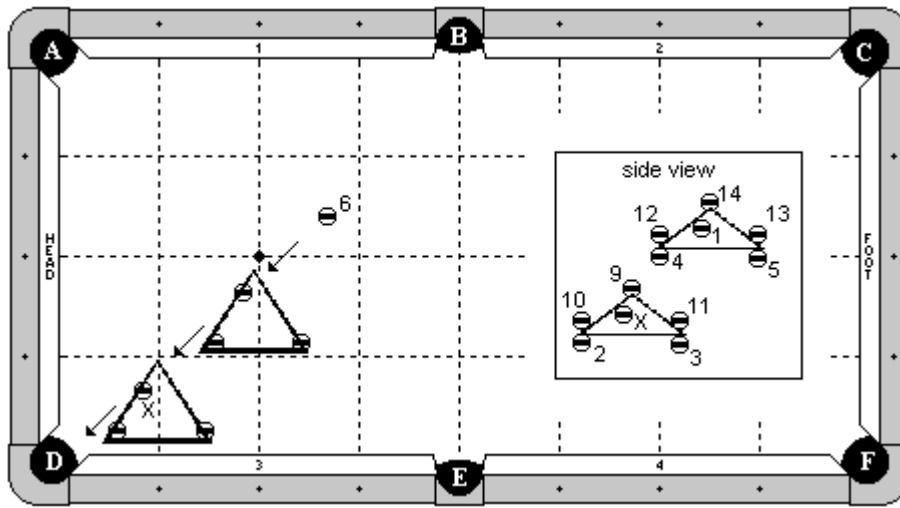

Category

Miscellaneous

Difficulty: 9

Cue Ball

Under the first rack as diagrammed. The cue ball is marked at position X.

Object Ball

The 2 and 3 balls are under the first rack. The 1, 4, 5 balls are under the second rack. The 9,10,11 are on top of the first rack. The 12,13,14 are on top of the second rack. All balls are shown in the side view for clarity. The player has the option of using chalk under the top balls in order to keep them from rolling off. The 6 ball is in hand.

Props

Two racks are balanced on top of the balls and in hand at the approximate positions shown.

Objective

Shoot the 6 ball into the 1 ball, causing the 1 ball to roll into the cue ball. The cue ball will then go into pocket D. The 6 ball will stay under the second rack and the 1 ball will stay under the first rack. Both racks and all balls will remain balanced.

Special Notes

Players must use 1 wooden rack and 1 Delta-13 rack. Players are free to choose which position each rack is in. If the player elects to use chalk to help balance the balls, the chalk doesn't need to be new.

Shot 190

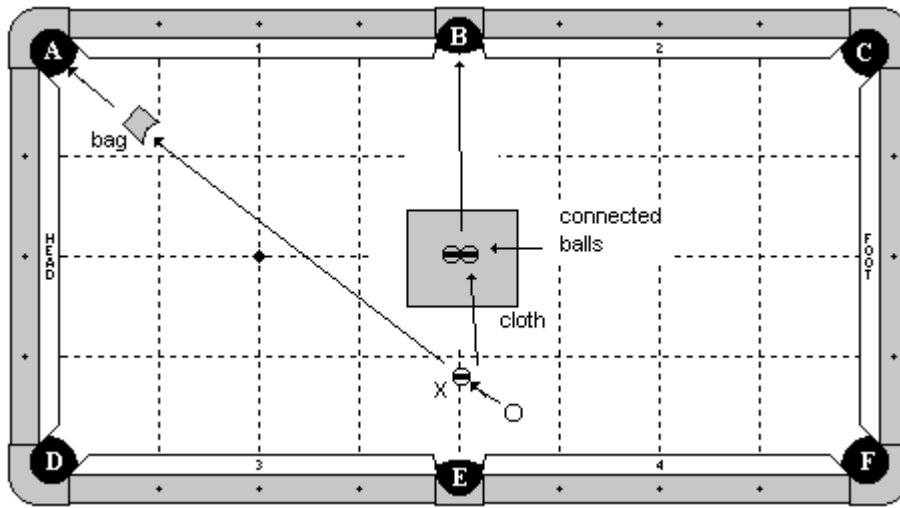

Category

Miscellaneous

Difficulty: 10

Cue Ball

In hand

Object Ball

'X' ball in hand.

Props

Bag on the table and in hand. Siamese (connected) balls centered on the table and along the long center line. 14x14 inch cloth is placed over the Siamese balls and centered as close as possible over them. Bag dimensions: 6 inches long, 4 inches wide, 2.5 inches opening height. Players may use their own bag provided their bag's dimensions are within $\frac{1}{4}$ inch plus or minus from the dimensions given.

Objective

Shoot the cue ball to 'X' ball, making it go through the bag and into pocket A. Shift body and re-hit the cue ball into the Siamese balls, making both of them in pocket B.

Special Notes

The Siamese balls must be moving before 'X' ball goes into pocket A. At the conclusion of the shot, the bag may not be overhanging pocket A and it must be flat on the surface of the table. In addition, no part of the cloth may go into pocket B.